



**DHANALAKSHMI SRINIVASAN ENGINEERING COLLEGE
(AUTONOMOUS)**

(Approved by AICTE & Affiliated to Anna University, Chennai)
Re-Accredited by NAAC with 'A' Grade
Accredited by NBA for AERO, BME, CSE, ECE, EEE, IT & MECH.
PERAMBALUR-621212, TAMILNADU, INDIA.
Website: www.dsengg.ac.in



COURSE PLAN

Name of the Faculty	R.SATHISH			
Designation/Department	ASSISTANT PROFESSOR / EEE			
Course Code/Name	U23EEV15/ POWER PLANT INSTRUMENTATION AND CONTROL			
Year/Section/Department	III / EEE			
Credits Details	L: 3	T: 0	P: 0	C: 3
Total Contact Hours Required	45			

Syllabus:

UNIT I/ OVERVIEW OF POWER GENERATION	No. Of Periods: 9
Brief survey of methods of power generation – hydro, thermal, nuclear, solar and wind power – importance of instrumentation in power generation – thermal power plants – building blocks – details of boiler processes – P&I diagram of boiler – cogeneration	
UNIT II/ MEASUREMENTS IN POWER PLANTS	No. Of Periods: 9
Electrical measurements – current, voltage, power, frequency, power factor etc. – non electrical parameters – flow of feed water, fuel, air and steam with correction factor for temperature – steam pressure and steam temperature – drum level measurement – radiation detector – smoke density measurement – dust monitor.	
UNIT III/ ANALYZERS IN POWER PLANTS	No. Of Periods: 9
Flue gas oxygen analyzer – analysis of impurities in feed water and steam – dissolved oxygen analyzer – chromatography – PH meter – fuel analyzer – pollution monitoring instruments.	
UNIT IV/ CONTROL LOOPS IN BOILER	No. Of Periods: 9
Combustion control – air/fuel ratio control – furnace draft control – drum level control – main steam and reheat steam temperature control – super heater control – at temperature – deaerator control – distributed control system in power plants.	
UNIT V/ TURBINE – MONITORING AND CONTROL	No. Of Periods: 9
Speed, vibration, shell temperature monitoring and control – steam pressure control – lubricant oil temperature control – cooling system- Green energy, Hydrogen & fuel cell.	

UNIT – I

HYDRO-ELECTRIC POWER PLANT

Introduction

The hydro-power plays a very important role in the development of the country as it provides power at cheapest rate being perpetual source of energy (Nearly 20% of the total world power is generated using hydro-plants.)

The quantity of water available and head is equally important in the generation of power. The available head depends upon the selection of site for hydraulic power plant./The site of the power plant is always selected for the highest available head. The quantity of water available at the selected site depends upon the hydrological cycle of nature. As the availability of water depends on the natural phenomenon of rain, the maximum capacity of hydraulic generating plant is usually fixed on the basis of minimum quantity of water available.

Hydrology

The science which deals with rainfall and run-off is known as hydrology. The evaporation of the water from the surfaces of river and oceans and its precipitation of the earth is known as hydrological cycle. The distribution of precipitation on the earth surface and beneath the earth is calculated with the help of hydrological considerations.

The rainfall, known as precipitation is the natural process of converting atmospheric vapour in to water. As the rain falls upon the drainage basin, a portion of it is evaporated directly by the sun, another large portion is taken up by vegetation and growing crops particularly in growing season and some percolates in to the ground. The percolating water may be partly absorbed by the roots of vegetation or it may reappear in course of time as spring water either inside or outside the catchment area/The remaining portion of rainfall flows through the catchment area on the surface of the earth and is known as "runoff")

Hydrograph Hydrograph is defined as a graph showing discharge run off) of flowing water with respect to time for a specified time. The time period for discharge hydrograph may be hour, day, week or month. The discharge may be m/sec, km²- cm/hr or day-second-metre. Discharge hydrographs are known as flood or run-off hydrographs. Each hydrograph has a reference to a particular riversite.

Classification of Hydro-electric power plants

1. Classification according to the availability of head

- a. Low head power plants
- b. Medium head power plants

- c. High head power plants
2. Classification according to the nature of load
- a. Base load plants
 - b. Peak load plants
3. Classification according to the quantity of water available
- a. Run-off River plant without pondage
 - b. Run-off River plant with pondage
 - c. Storage type plants
 - d. Pump storage plants
 - e. Mini & Micro-Hydel plants
 - f. height of water in the reservoir.

The water entering in to the turbine rotates the turbine shaft and ultimately the generator shaft which is coupled to turbine shaft. The current flows from the generator to the transformer where the voltage is stepped up to be transmitted by huge pylons

Operation of Hydro-Electric Power Plant

In hydro-electric plants, the potential energy of water is converted in to kinetic energy first passing through the tunnel to the power house. The Kinetic energy of the water is converted in to mechanical energy in the water turbines. The mechanical energy of the water turbine is further utilized to run the electric generator. This is the common principle of hydro-electric. The load on the generator fluctuates according to the demand, therefore, the mechanical power developed by the turbine must also change and that is controlled by the governor by changing the quantity of water supplied to the turbine.

Components used in Hydro-Electric Power Plant

- Reservoir
- Dam
- Trash rack
- Forebay
- Surge Tank
- Penstock
- Spill way
- Power House

- Prime movers room
- Draft tube

The functions of different components used in hydro-electric power plant are described below:

Reservoir

The main Purpose of the reservoir is to store the water during rainy season and supply the same during dry season

Dam

The function of the dam is to increase the height of the water level behind it which ultimately increases the reservoir capacity. The dam also helps to increase the working head of the power plant. Many times high dams are built only to provide the necessary head to the power plant.

Trash Rack

The water intakes from the dam or from the fore bay are provided with trash rack to prevent the entry of debris which might damage the wicket gates and turbine runners or choke-up the nozzles of the impulse turbine.

If the winters are severe, special provision is made to prevent the trouble from ice. To prevent ice from clinging to the trash racks, they are often heated electrically. Sometimes an air bubbling system is provided in the vicinity of the trash rack which brings warmer water to the surface of trash racks.

Forebay

The forebay serves as regulating reservoir temporarily storing water when the load on the plant is reduced and provides water for initial increment of an increasing load while water in the canal is being accelerated. In many cases, the canal itself may be large enough to absorb the flow variations.

If the canal is long, its end is sometimes enlarged to provide necessary temporary storage. In short, forebay is a naturally- provided storage which is able to absorb the flow variations. This can be considered as naturally provided surge tank as it does the work of surge tank. The forebay is always provided with some type of outset structure to direct water to the penstock depending upon local conditions.

Surge Tank

A surge tank is introduced in the system between the dam and power-house nearest to the power house and preferably on the high ground to reduce the height of the tower to provide better regulation of water pressure in the system during variable load conditions.

When the turbine gates are partly closed and water flow in to the turbine is reduced suddenly, water rises in the surge tank. This produces a retarding head and decreases the velocity of water in the penstock. When the velocity of the water in the penstock is reduced to the value demanded by the turbine, the level of the water in the surge tank starts falling and fluctuates up and down till its motion is damped out by friction. When there is sudden rise in the load on the turbine, additional water is supplied from surge tank. This lowers the water surface in the surge tank thus producing an accelerating head which increases the flow of water in the penstock. When the discharge of water corresponds to the turbine demand, the water surface in the tank ceases to fall. The surge tank thus helps in stabilizing the velocity and pressure in penstock and reduces the water hammer effect.

Penstock

The structural design of the penstock is same as for any other pipe except it has to bear very high pressure on inside surface during decreased load conditions on generator and on outside surface during increased load conditions of generator. A pipe between the surge tank and prime-mover is known as penstock.

In very cold weather conditions, it is sometimes advised to bury the penstock to prevent the ice formation in the pipe and to reduce the number of expansion joints required. Uncovered penstocks are usually more expensive because of the expansion joints, anchors and other apparatus required but they have the advantage of being accessible for inspection and repairs.

Spillway

Spillway is considered a safety valve for a dam. It must have the capacity to discharge major floods without damage to the dam and at the same time keeps the reservoir level below some predetermined maximum level.

Power House

A power house consists of two main parts, a sub-structure to support the hydraulic and electric equipment and superstructure to house and protect this equipment.

The elevation of the turbine with respect to the tail water level determined by the necessity of avoiding cavitations. It is always advantageous to locate the power houses underground under certain topographic conditions where there is no convenient site for conventional type.

Prime Movers

The main purposes of the prime movers are to convert the kinetic energy of water in to mechanical energy to produce electric energy. The prime movers which are in common use are pelt on turbine, Francis turbine, Kaplan turbine and propeller turbines.

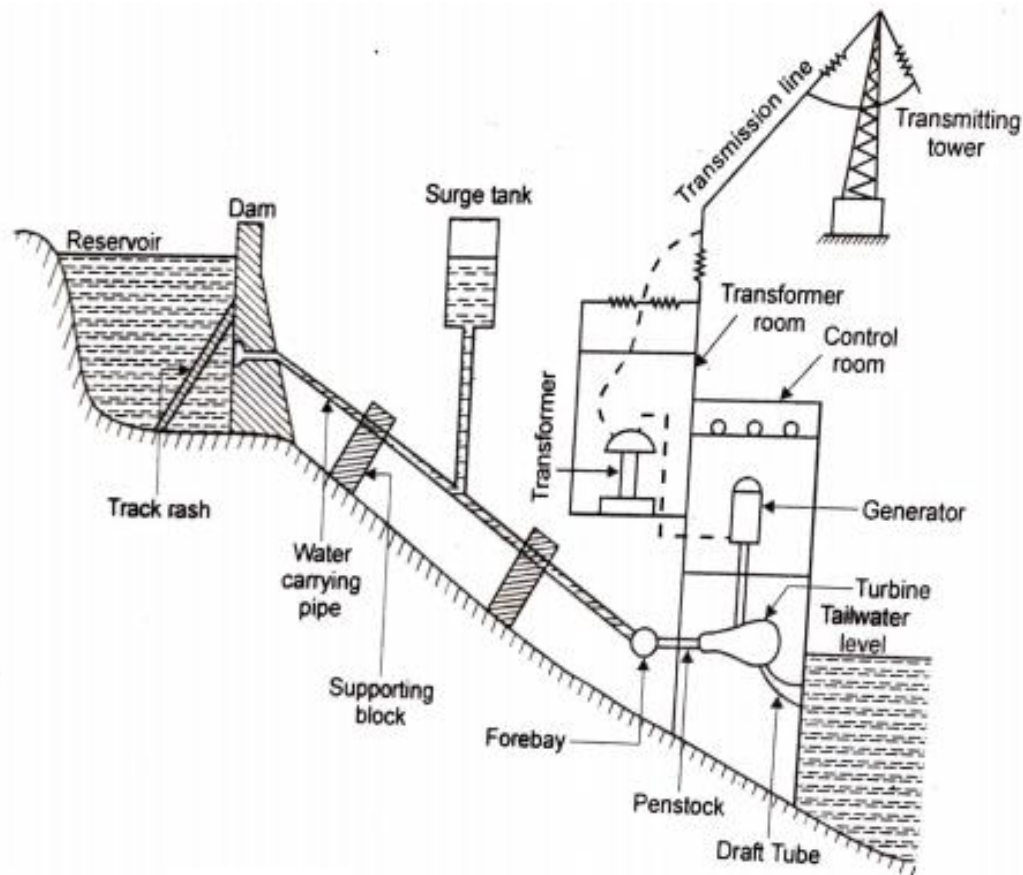

Hydro - Electric power plant

Draft tube

The draft tube is essential part of reaction turbine installation. It supplements the action of the runner by utilizing most of the remaining kinetic energy of the water at the discharge end of the runner. The draft tube is a diverging discharge passage connecting the running with tailrace. It is shaped to decelerate the flow with a minimum loss so that the remaining kinetic energy of water

coming out of runner is efficiently regained by converting in to suction head, thereby increasing the total pressure difference on the runner. The regain of kinetic energy of water coming out from reaction turbines is the primary function of the draft tube.

Thermal Power Plant

The development of power in any country depends upon the available resources in that country. The hydel power totally depends upon the natural sites available and hydrological cycle in that country. The development of nuclear power in a country requires advanced technological developments and fuel resources. This source of power generation is not much desirable for the developing countries as it is dependent on high technology and they are highly capital based systems.

Many times, hydel power suffers if draught comes even once during a decade and the complete progress of the nation steps. The calamity of rain draught on power industry has been experienced by many states in this country. To overcome this difficulty it is absolutely necessary to develop thermal plants in the country which are very much suitable for base load plants. Hydel power plants are much better for peak load requirements; therefore the development of the thermal plants becomes a necessity for economic generation of the power.

The development of all three sources should be made simultaneously if possible to assure sound supply of power in the country. The mix of three depends upon the availability in that particular area but it is always economical and desirable to develop all sources of power for steady and sure progress of the country.

Circuits in Thermal Power Plant

The general layout of the thermal Power Plant consists mainly four circuits as shown in fig. The four main circuits are

1. Coal and ash circuit
2. Air and Gas circuit
3. Feed water and steam flow circuit .
4. Cooling water circuit

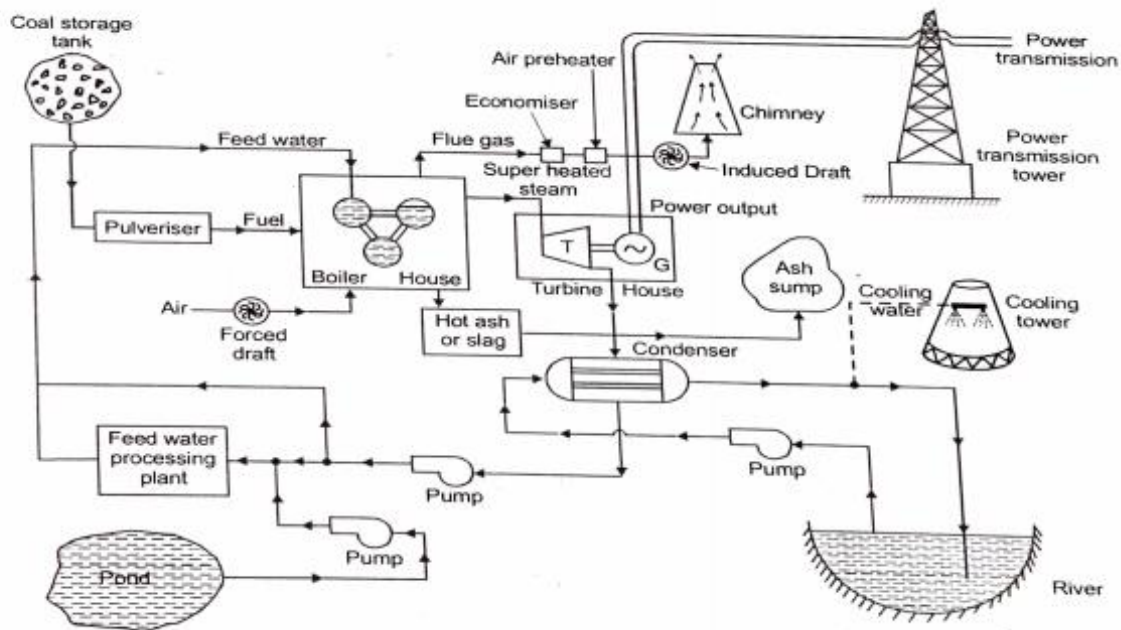

Thermal Power Plant

A thermal power station using steam as working fluid works basically on the Rankine cycle. Steam is generated in a boiler, expanded in the prime mover and condensed in condenser and fed in to the boiler again.

Coal and Ash circuit

In this circuit, the coal from the storage is fed to the boiler through coal handling equipment for the generation of steam. Ash produced due to the combustion of coal is removed to ash storage through ash-handling system.

Air and Gas circuit

Air is supplied to the combustion chamber of the boiler either through Forced Draft or Induced Draft fan or by using both. The dust from the air is removed before supplying to the combustion chamber.

The exhaust gases carrying sufficient quantity of heat and ash are passed through the air-heater where the exhaust heat of the gases is given to the air and then it passed through the dust collectors where most of the dust is removed before exhausting the gases to the atmosphere through chimney.

Feed water and Steam circuit

The steam generated in the boiler is fed to the steam prime mover to develop the power. The steam coming out of prime mover is condensed and then fed to the boiler with the help of pump. The condensate is heated in the feed-heaters using the steam tapped from different points of the turbine. The feed heaters may be of mixed type or indirect heating type.

Some of the steam and water is lost passing through different components of the system, therefore, feed water is supplied from external source to compensate this loss. The feed water supplied from external source is passed through the purifying plant to reduce the dissolved salts to an acceptable level. The purification is necessary to avoid the scaling of the boiler tubes.

Cooling water circuit

The quantity of cooling water required to condense the steam is considerably large and it is taken either from lake, river or sea. The cooling water is taken from the upper side of river, it is passed through the condenser and heated water is discharged to the lower side of the river. Such system of cooling water supply is possible if adequate cooling water is available throughout the year. This system is known as open system.

When the adequate water is not available, then the water coming out from the condenser is cooled either in cooling pond or cooling tower. The cooling is done by partly evaporating the water. When the cooling water coming out of the condenser is cooled again and supplied to the condenser, then the system is known as closed system.

Working of Thermal power plant

Steam is generated in the boiler of the thermal power plant using the heat of the fuel burned in the combustion chamber. The steam generated is passed through steam turbine where part of its thermal energy is converted into mechanical energy which is further used for generating electric power. The steam coming out of the steam-turbine is condensed in the condenser and the condensate is supplied back to the boiler with the help of the feed pump and the cycle is repeated.

The function of the boiler is to generate the steam. The function of the condenser is to condensate the steam coming out of steam turbine at low pressure. The function of the steam turbine is to convert part of heat energy of steam into mechanical energy.

The function of the pump is to raise the pressure of the condensate from the condenser pressure (0.015atm) to boiler pressure (200 atm) the other components like economizer, superheated and steam feed heaters (steam from Raw coal different points of turbine is fed to the heaters to heat the condensate to a higher temperature) are used in the primary circuit to increase the overall efficiency of the thermal power plant.

Different types of systems and components which are used in thermal power plants

- Coal handling system
- Ash and dust handling system
- Draft
- prime-mover
- condenser's and cooling towers
- Feed water purification plant
- Economizers
- Super heater
- Feed heaters etc.

Coal Handling System

Two methods are in general use to feed the pulverized fuel to the combustion chamber of the power plant.

i) Unit System

ii) Central or Bin System

In unit system, each burner of the plant is fired by one or more unit pulverizers connected to the burners, while in the central system, the fuel is pulverized in the central plant and then distributed to each furnace with the help of high pressure air content. Each type of fuel handling system consists of crushers, magnetic separators, driers, pulverizing mills, storage bins, conveyors and feeders. The arrangement of different equipments required in both systems is shown in figure with the help of block diagram.

The coal received by the plant from the mine may vary widely in sizes necessary to make the coal of uniform size before passing the pulverized for efficient grinding.

The coal received from the mine is passed through a preliminary crusher to reduce the size to allowable limit (30mm). The crushed coal is further passed over magnetic separator which removes pyrites and tramp iron.

In a unit system, each burner or a group of burners and a pulverizer constitute a unit. Crushed coal is fed to the pulverizer through feeder at a variable rate governed by the combustion requirements of furnace and steam generating rate required in the boiler.

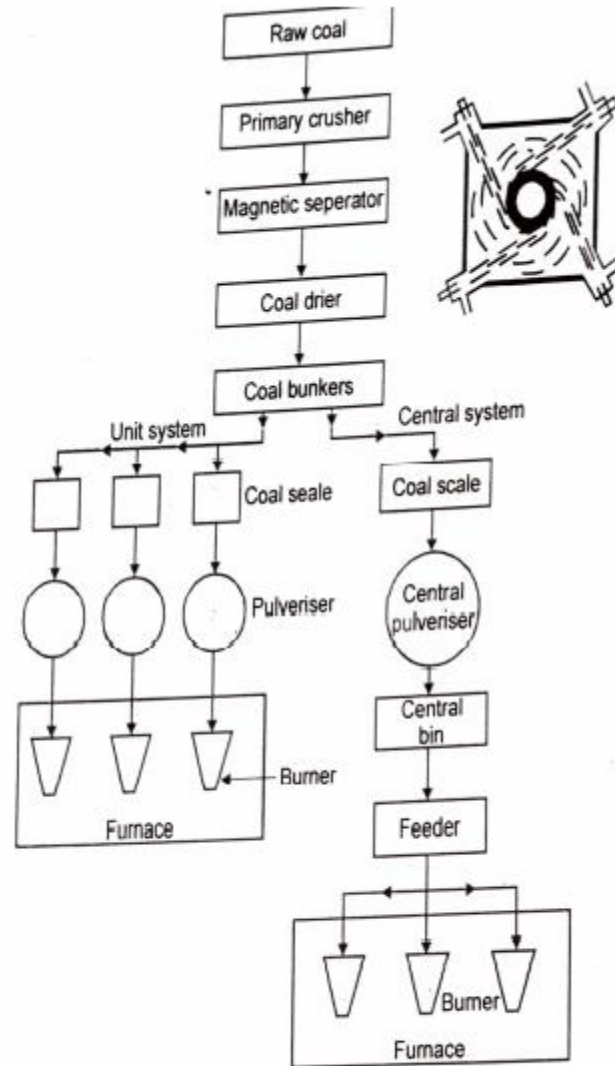

General layout of coal handling system

In a central feed system, the crushed coal is fed to the drier from the raw coal bunker by gravity. The drying of coal is effected either by using hot gases, preheated air or bled steam.

The dried coal is fed to the pulverizer with the help of feeder. The pulverized coal is carried from the pulverizer mill and it is separated in the cyclone separator.

Ash and Dust Handling System

Ash handling system comprises the following operations

- i) To remove the ashes from the furnace ash hopper.
- ii) To convey the ashes from furnace ash-hopper to a storage or fill with the help of conveyors.

iii) To dispose the ashes from the storage.

The ever increasing capacities of boiler units together with their ability to use low grade high ash content coals have been responsible for the development of modern ash handling systems. Mechanical handling system Hydraulic ash handling system. The general layout of the components used in modern ash handling and dust collection plant is shown in figure.

The modern ash-handling systems are mainly classified in to four groups namely

- Mechanical handling system
- Hydraulic ash handling system
- Pneumatic system
- Steam jet system

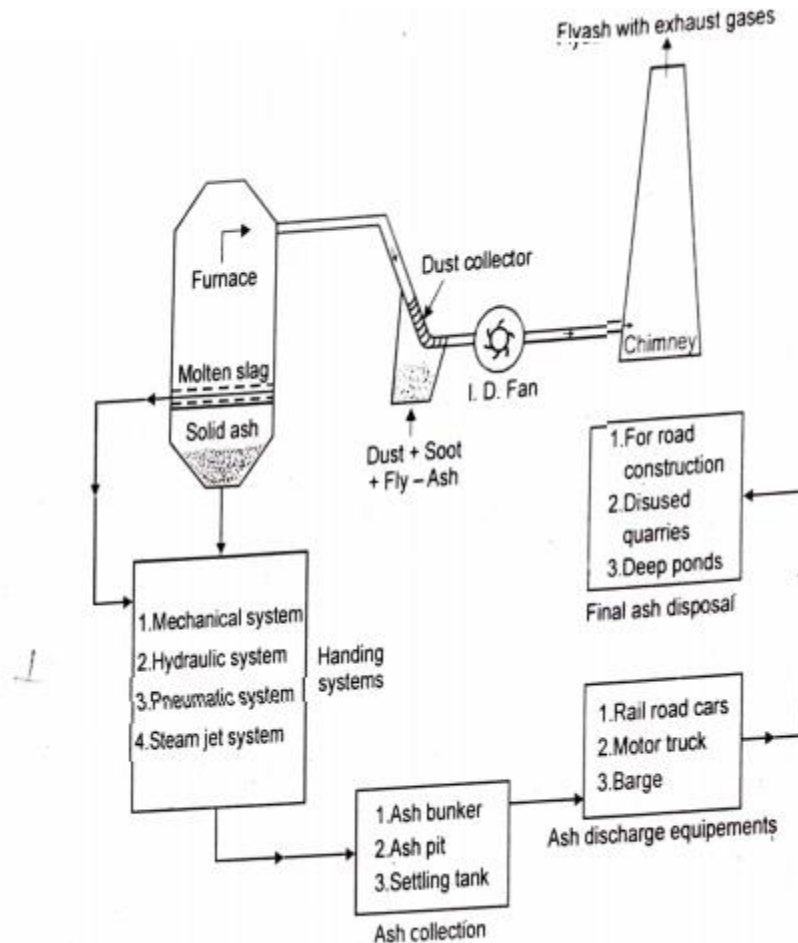

General layout of ash handling and dust collection system

The mechanical system is generally used for low capacity power plants using coal as fuel. The hot ash coming out of boiler furnace is made to fall over the belt conveyor through a water seal.

The cooled ash falls on the belt conveyor and it is carried continuously to the dumping site or overhead bunker. The ash is carried to the dumping site from the ash bunker with the help of trucks.

The hydraulic ash handling system carries the ash with the flow of water with high velocity through a channel and finally dumped to the sump.

The pneumatic ash handling system is more suitable to the boiler plants from which ash and soot must be transported some considerable distance for final disposal. The ash and dust from all discharge points are picked up by a high velocity air stream created by an exhaustor at the discharge end.

Draft Systems

The purpose of draft is to supply required quantity of air for combustion and remove the burnt products from the system. To move the air through the fuel bed and to produce a flow of hot gases through the boiler, economizer, preheater and chimney require a difference of pressure equal to that necessary to accelerate the burnt gases to their final velocity and to overcome the pressure losses equivalent to pressure head.

This difference of pressure required to maintain the constant flow of air and to discharge the gases through the chimney to atmosphere is known as draft. When the draft is produced with the help of chimney only, is known as Natural Draft and when the draft is produced by any other means except chimney, is known as artificial draft.

i) Forced Draft

In a forced draft system, a blower is installed near the base of the boiler and air is forced to pass through the furnace, economizer, air-preheated and to the stack. This draft system is known as positive draft system or forced draft system because the pressure of air throughout the system is above atmospheric pressure and air is forced to flow through the system.

The arrangement of the system is shown in figure. A stack or chimney is also used in this system but its function is to discharge gases high in the atmosphere to prevent the contamination. It is not much significant for producing draft therefore height of the chimney may not be very much.

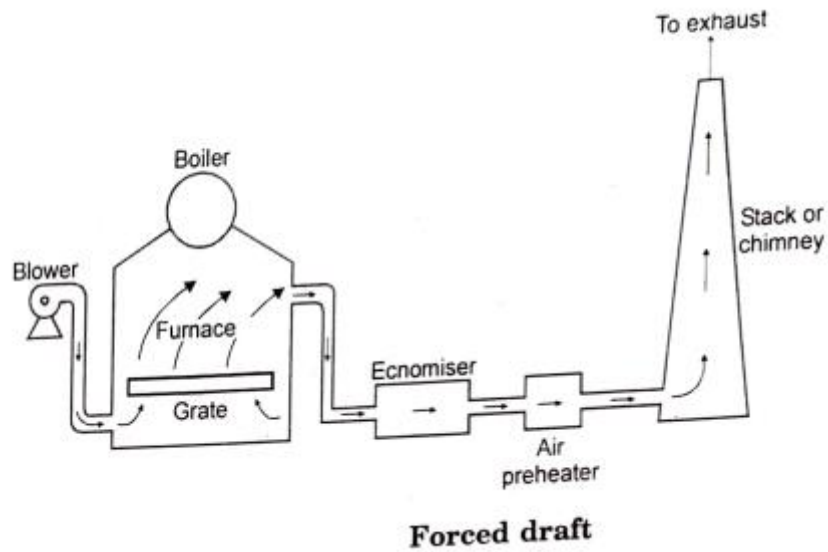

ii) Induced Draft

In this system, the blower is located near the base of the chimney instead of near the grate.

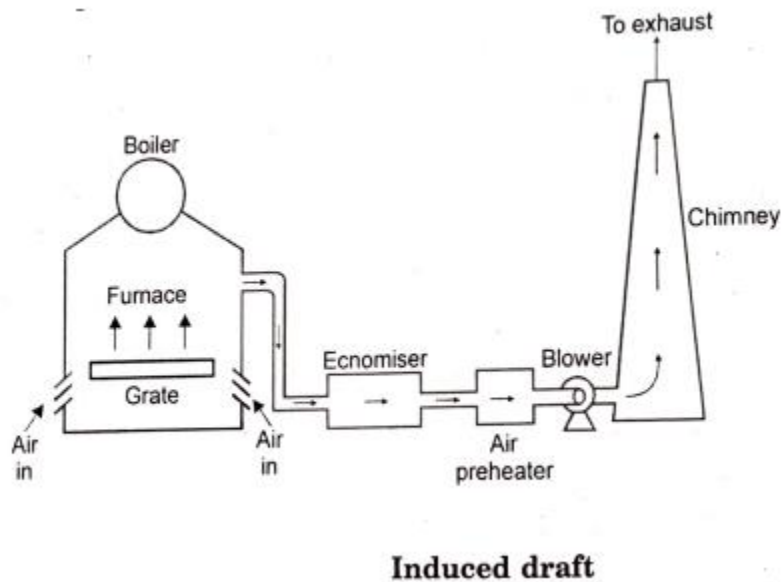

The air is sucked in the system by reducing the pressure through the system below atmosphere. The induced draft fan sucks the burned gases from the furnace and the pressure inside the furnace is reduced below atmosphere and induces the atmospheric air to flow through the furnace. The action of the induced draft is similar to the action of the chimney.

The draft produced is independent of the temperature of the hot gases therefore the gases may be discharged as cold as possible after recovering as much heat as possible in air-preheater and economizer. The fan should be located at such a place that the temperature of the gas handled by the fan is lowest. The chimney is also used in this system and its function is similar as in forced draft but total draft produced in induced draft system is the sum of the drafts produced by the fan and chimney as shown in figure.

Economisers

The economizer is a feed water heater deriving heat from the flue gases discharged from the boiler. The justifiable cost for economizer depends on the total gain in efficiency. In turn, this depends on the gas temperature going out of the boiler and feed water temperature to the boiler.

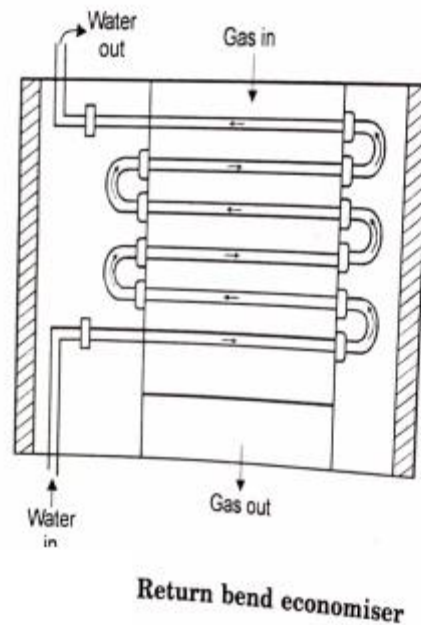

Regenerative cycle inherently gives high feed water temperature, therefore the adoption of economizer must be known. A typical return bend type economizer is as shown in figure.

Air Pre-heaters

The heat carried with the flue gases coming out of economizer are further utilized for preheating the air before supplying to the combustion chamber. It has been found that an increase of 20°C in the air temperature increases the boiler efficiency by 1%. It is also a necessary equipment for supply of hot air for drying the coal pulverized fuel systems to facilitate grinding and satisfactory combustion of fuel in the furnace.

A typical arrangement of tubular air-pre heater is shown in figure. The flue gases flow through the tubes and air is passed over the outer surface of the tubes as shown in figure. The horizontal baffles are provided to increase the time of contact while will help for higher heat transfer. In some design, tube-row staggering is used to improve the air-distribution.

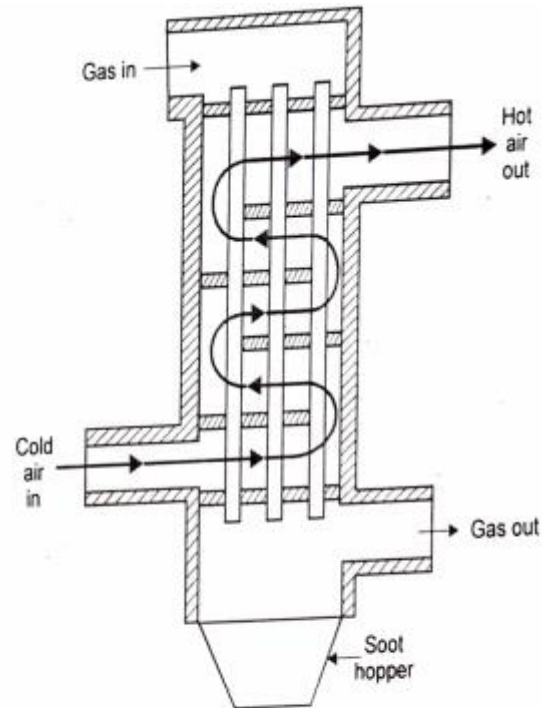

Tubular air preheater

SOLOR POWER PLANT

The radiation continuously showered on earth by the sun represents the most basic and inexhaustible source of energy which is the mother of all forms of energy. Life on this planet completely depends upon the constant flow of solar energy. The food production and life support system of nature depends upon the sun.

The interior of the sun has a temperature of above $25 \times 10^6^\circ\text{C}$. The hydrogen atoms in the sun fuse with helium atoms to produce energy. The solar energy travels in particles called photons. This energy reaches the surface of earth by direct mode and diffuse mode.

The daily average solar energy incident in the country varies from 5 to 7 KWhr per square metre. Approximately 5×10^{15} KWhr of energy per annum is received from the sun in India. The direct energy when collected can be converted in to heat energy through Solar Thermal Devices and Systems.

Heat energy, thus produced can be used for variety of applications in industries, dairies, hospitals, hotels, hostels etc. It can be used for generation of electric power, using steam cycle and conventional turbines.

Basic Principle

The solar energy is collected by large parabolic collectors. This energy is used to heat water. The feed water is heated in two stages to produce steam to run the turbines. The alternators coupled to turbines produce the required electrical energy. Steam is condensed and feed water returned to boiler for reuse.

Solar Thermal Conversion

1. Flat plate collector
2. Solar Air Heater
3. Cylindrical Parabolic Concentrating or focussing Solar Collector
4. Paraboloid Concentrating Solar Collector
5. Sensible Heat Storage Systems

Flat Plate Collector

The collector used for collection of solar energy should have high absorption and low emissivity. A flat plate collector is as shown in Figure. In any collector device, the principle followed is to expose the dark surface to solar radiation so that the radiation is suitably absorbed.

A part of this absorbed radiation is transferred to a fluid like air or water. It can be used for a variety of applications in which temp ranges from 40°C to about 100°C are required.)A flat plate collector consists of an absorber plate on which the solar radiation falls after coming through one or more transparent covers, usually made of glass.

The absorbed radiation is partly transferred to a liquid flowing through tubes fixed to the absorber or integral with it, and the rest is lost to the surroundings by convection and radiation. The liquid mostly used is water. A flat plate collector is usually held tilted in a fixed position on a supporting structure, facing south if located in the northern hemisphere.

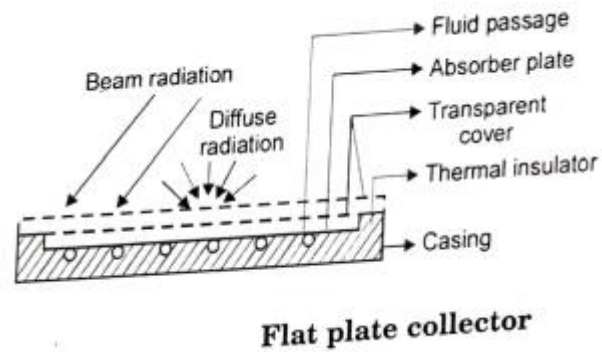

Solar air heater

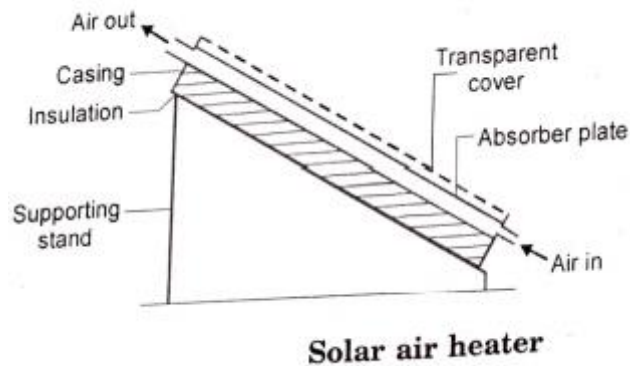

A schematic cross-section of a conventional solar air heater is as shown in figure, which is essentially similar to that of a liquid flat-plate collector except for the passages through which air flows.

Cylindrical Parabolic Concentrating Solar Collector

When temperatures higher than 100°C are received, it becomes necessary to concentrate the radiation by the use of focusing or concentrating collectors as shown in figure. The collector consists of a concentrator and a receiver. The concentrator as shown is a mirror reflector having the Receiver -Concentrator shape of a cylindrical parabola.

It focuses the sunlight on to its axis where it is absorbed on the surface of the absorber tube and transferred to the fluid flowing through it. A concentric glass cover around the absorber tube helps in reducing the convective and radioactive losses to the surroundings. In order that the sun's rays should always be focused on to the absorber tube, the concentrator has to be rotated. This movement is called tracking. In the case of cylindrical parabolic concentrators rotation

about a single axis is generally required. Fluid temperatures up to around 300°C can be achieved in such systems.

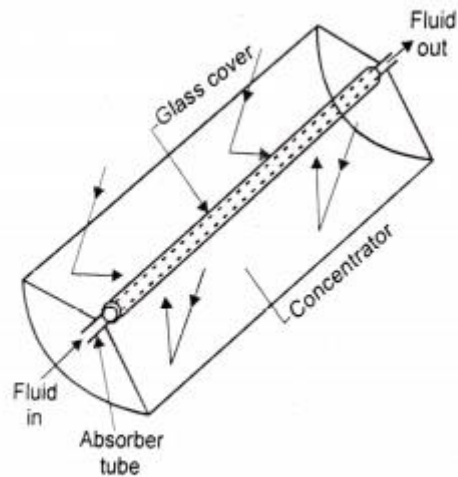

Cylindrical parabolic concentrating solar collector

Parabolic concentrating collector

The generation of higher working temperatures is possible by using parabolic reflectors which have a point focus.

This requires two-axis tracking so that the sun is in line with the focus and the vertex of the parabolic as shown in figure.

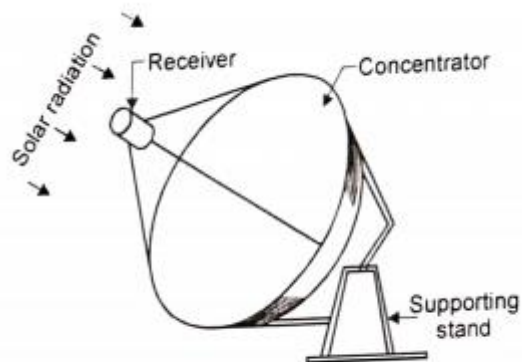

Paraboloid concentrating collector

Energy storage systems

One of the major problems associated with the utilization of solar energy is its variability.

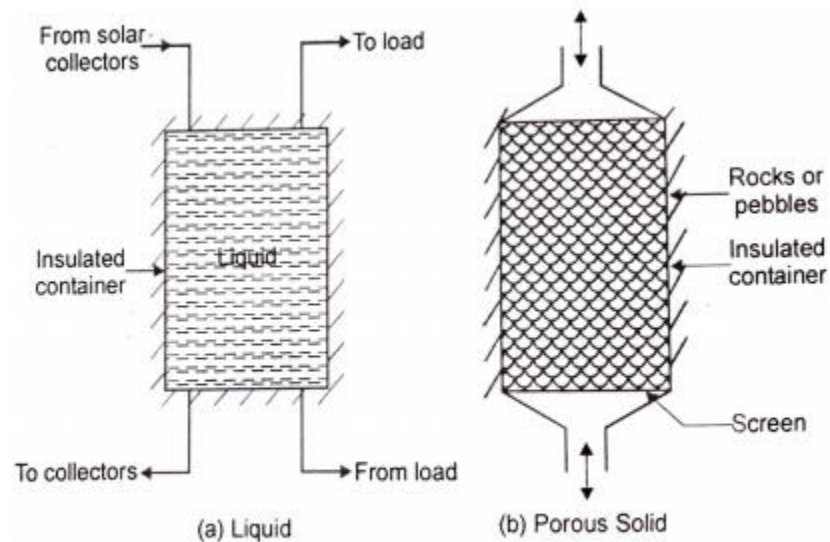

Sensible heat storage

for this reason, most applications require some type of energy storage system, the purpose of which is to store energy when it is in excess of the requirement and to make it available for extraction when the supply of solar energy is absent or inadequate.

Solar energy can be stored as sensible heat or latent heat. Sensible heat storage is usually done in an insulated container containing a liquid like water or a porous solid in the form of pebbles or rocks as shown in figure.

The first type is preferred with liquid collectors, while the second type is compatible with air heaters. In the case of latent heat storage, heat is stored in a substance when it melts and extracted when the substance freezes.

Solar Thermal Power Generation

Low temperature solar power plant (up to 100°C)

The energy of the sun is collected by water flowing through an array of flat-plate collectors as shown in figure.

To get still higher temperatures, booster mirrors which reflect radiation on to the flat-plate collectors are sometimes used.

The hot water at about 100°C is stored in a well insulated thermal storage tank. From storage tank, it flows through a vapors generator through which the working fluid is passed. The working fluid has a low boiling point. Consequently, vapor at about 90°C and a pressure of a few atmospheres leaves the vapor generator. This vapor then executes a regular cycle by flowing through a prime mover, a condenser and a pump.

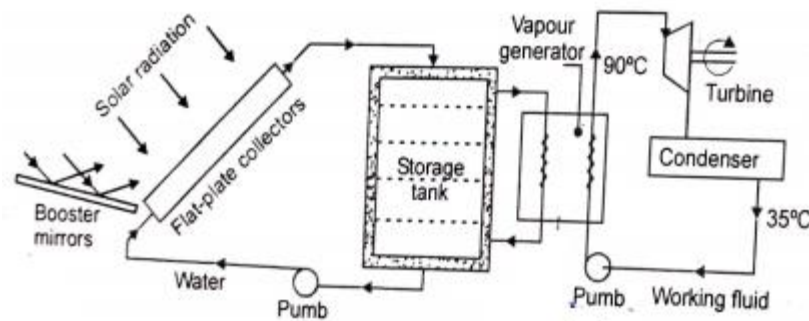

Low temperature solar power plant

Medium Temperature System (above 100°C to 250°C)

It can be attained by using arrays of cylindrical parabolic focusing collectors. The axes of these collectors could be oriented north-south or east west and tracking about these axes would be required.

The fluid flowing through the absorber tubes is a high-boiling-point liquid. It is stored in tanks and drawn through a heat-exchanger in which it transfers heat to high pressure water which is converted in to steam.

High temperature solar power plant (above 250°C)

The central receiver tower solar power plant consists basically five subsystems as shown in figure.

- The heliostat field
- The sodium heat transfer system
- The power conversion system
- The electrical system
- The data acquisition system

Heliostat array made of plastic sheets with protective coating are used reflect sun rays to central receiver tower (500m high). The heliostats continuously track the sun by optical guides and focus the lower top where heat transport fluid is heated and piped to ground for turbo generator drive.

Liquid sodium is used as a cooling medium for the receiver due to its excellent thermal transmission characteristics. Solar concentration ratio of about 1000 is achieved with a temperature range of 480°C 540°C which suits turbine characteristics. Such plants are operative up to 500 kW capacities which need four acres of land for heliostats infrastructure.

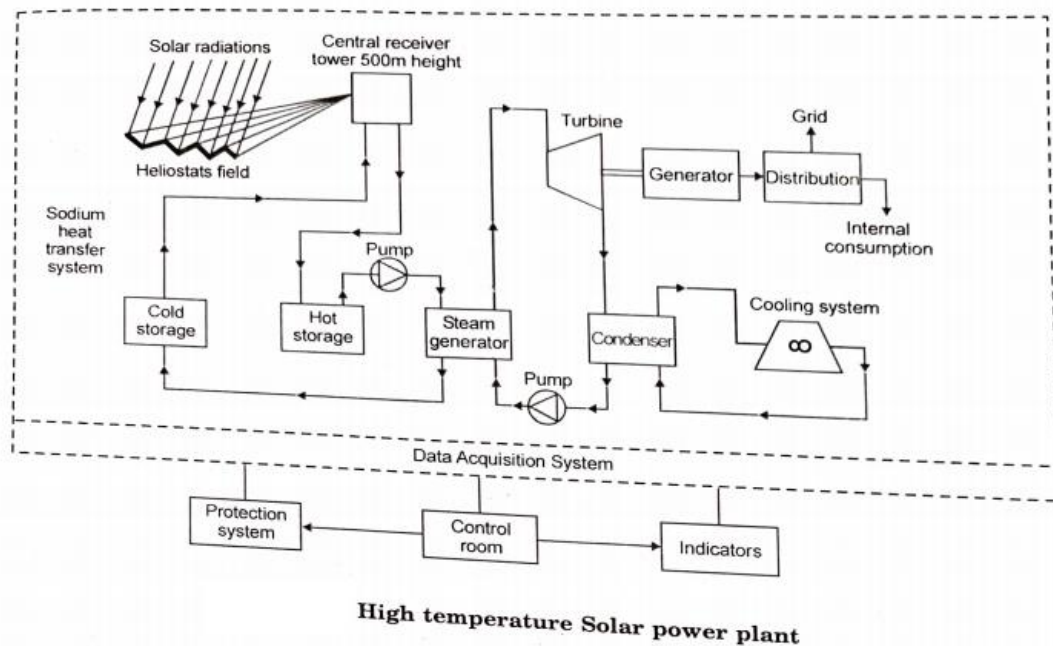

Two sodium tanks are integrated in to sodium heat transfer system to form a thermal store. A conventional water steam circuit in conjunction with steam turbine and generator converts thermal energy which has been transferred to a steam generator by the sodium heat transfer system in to electrical energy.

The electrical system provides power to all its auxiliaries. However an emergency diesel generator and batteries are maintained. The electric power is fed to the grid through a transformer.

A data acquisition system is maintained in the control room for monitoring and logging normal operations and for evaluation of system.

Photo Voltaic Power Generation

Photo voltaic power generation is a method of producing electricity out of a semi-conductor by means of a quantum effect which converts optical energy in to electrical energy as shown in figure.

If an n-type semi-conductor is brought in to contact with a p-type semiconductor a contact potential difference will be established at the interface by the diffusion of the electrons. With the p-type semiconductor exposed to light, its electrons absorbs photons of light and pass it to n-type region, thus generating an electric current in a closed circuit. Such cells are Solar Cells. Solar cells can be connected in series and parallel in the form of array on a panel to get the desired rating of voltage and current. The maximum possible rating is 250W/m² of array. So a power plant of 250M W needs an array surface of one square kilometer.

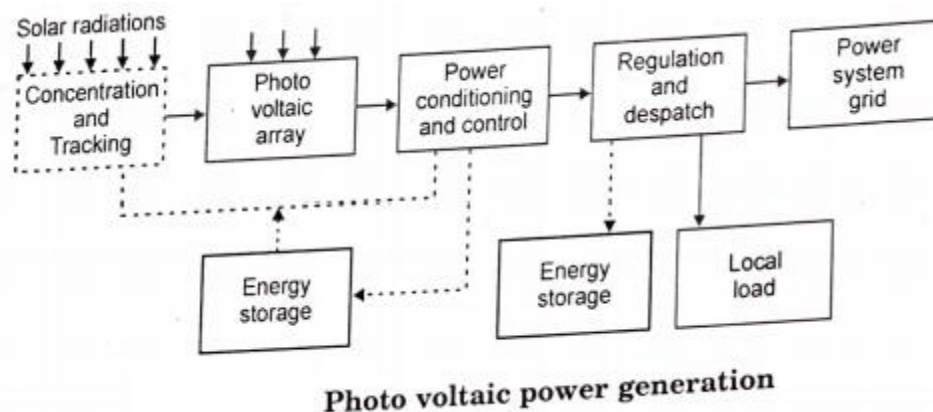

The solar energy is directly received by the photovoltaic cells and it can be increased by use of concentration and tracking system. The output of the photovoltaic cells array is DC so it is converted in to a.c. for local use and feeding the grid. This can be done by suitable regulation and despatch unit.

NUCLEAR POWER PLANTS

The discovery of the fission of Uranium was the tremendous importance as it opened the prospects of using the energy stored in the atomic nucleus for the production of electric power.

Presently, the nuclear energy enormously enlarged the world's power sources. The present estimates reveal that fissionable Uranium alone contains moderated far more energy that all the world's reserves of coal and petroleum put together.

A unique feature of nuclear energy is an exceptionally high degree of concentration which exceeds by millions of times the concentration of energy in the conventional fossil fuels.

For example the energy of one kg of Uranium is equivalent to about 20×10^6 KW-hrs of heat energy or burning of 2000 tons of high grade coal.

In the nuclear power plant, the energy released by splitting the nuclei of Uranium is converted in to the heat energy of steam and then into electric

Nearly all the energy released by nuclear fission transforms to heat. The device in which a nuclear fission chain reaction takes place is known "nuclear reactor".

The only difference between conventional thermal power plants and nuclear plants is that in the former water is heated to combustion generate steam by of coal while in the latter the required heat is generated in nuclear reactors.

Classification of reactors

1. On the basis of neutron Energy

- a) Fast Reactors
- b) Thermal Reactors

2. On the basis of fuel used

- a) Natural Fuel
- b) Enriched Uranium

3. On the basis of moderator used

- a) Water moderated
- b) Heavy water moderated
- c) Graphite moderated
- d) Beryllium moderated

4. On the basis of coolant used

- a) Water cooled reactors
- b) Gas cooled reactors
- c) Liquid metal cooled reactors

d) Organic liquid cooled reactors

Pressurized Water Reactor (PWR)

The arrangement of pressurized water reactor is shown in figure. A pressurized water reactor is a light water cooled and moderated reactor. It uses enriched Uranium as fuel.

The pressurizing tank included in the circuit maintains the constant pressure in the circuit throughout the load range. Electric heating coil in the pressurized boils the water to form the steam which is collected in the dome reactors as shown in figure and pressurizes the entire coolant circuit before starting reactor. To reduce the pressure, water spray is used to condense the steam. The fuel which is generally used is UO. The Uranium Oxide is highly resistant to irradiation damage and is very well adapted to the high burn-ups. It's also highly resistant to corrosion by high pressure water in the event of a break-up in the fuel cladding.

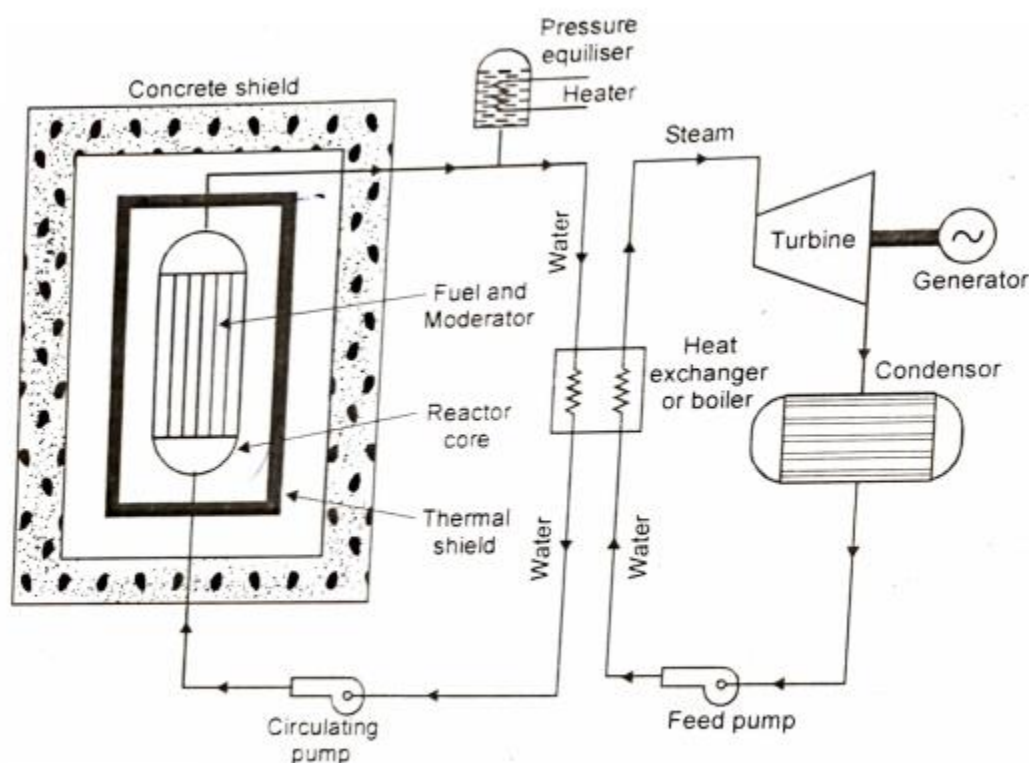

Pressurized water reactor nuclear power plant

The water in the primary circuit gets heated by absorbing the fission energy in the reactor core and same energy is given in the heat exchanger to generate the steam. The water coming out of the heat exchanger is circulated by the pump to maintain the pressure in the circuit in the range of 100 to 130 atm.

The water becomes radioactive in passing through the reactor, therefore, the entire primary circuit including steam generator (heat exchanger) must be shielded to protect the operating persons. The radioactive coolant does not make the steam radioactive in the boiler.

Boiling Water Reactor (BWR)

In this type of reactor, enriched Uranium is used as fuel and water is generated in the reactor itself instead of separate steam boiler. The arrangement of the single circuit system is shown in figure.

The majority of the power plants in U.S.A. are of PWR and BWR types as diffusion plants are established for enrichment of fuel during Second World War.

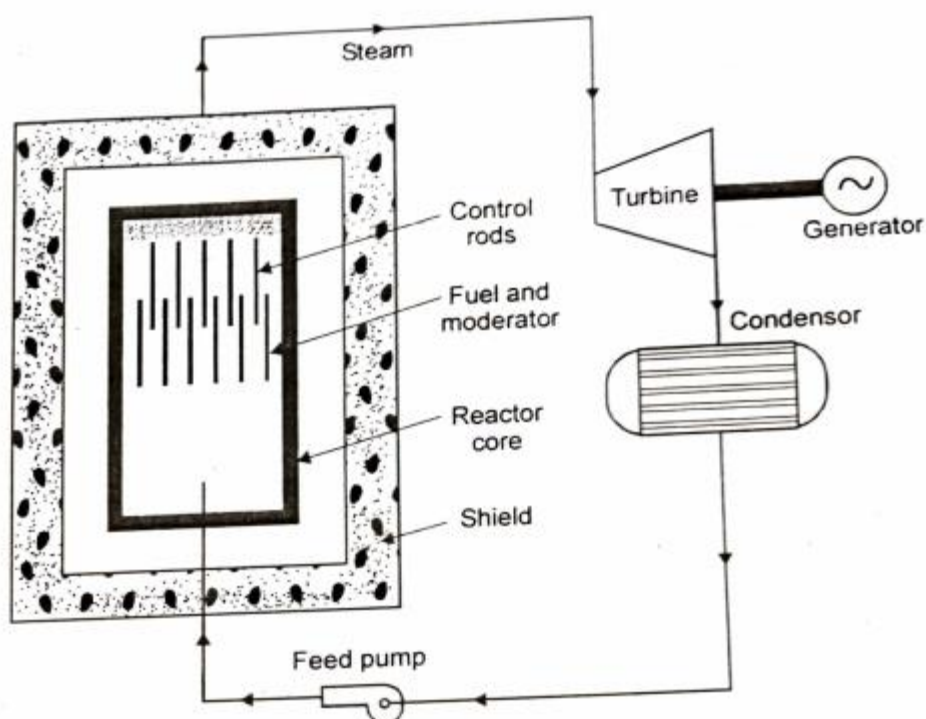

Boiling water reactor nuclear power plant

Components used in Nuclear Reactor

- Reactor Core
- Moderator
- Reflector
- Coolant system
- Control rods

- Biological shield
- Boiler
- Turbine
- Generator
- Condenser

The principle component of a nuclear power plant is its nuclear reactor made up of the following:

- i) Core is main part in which nuclear reaction takes place and heat energy is released.
- ii) Moderator is required to slowdown the fast moving neutrons so as to utilize them for fission.
- iii) Coolant system transfers heat from the reactor core to the feed water.
- iv) Control system is provided for controlling the release of energy due to fission.
- v) Reflector is provided to reflect back unused neutrons in to the core for improving the neutron economy of the reactor.
- vi) Reactor vessel is a strong walled container housing the core for the reactor.
- vii) Biological shield is provided to protect the personnel against radiation hazards

Reactor Core

The core consists of large number of fuel tubes in which nuclear fuel is placed in the form of Uranium or Plutonium rods clad with a hermetically sealed metal jacket. The fuel rods are referred to as fuel elements. It is in these rods that the nuclear reaction takes place and large amount of heat is released in the process. There may be as many as a few thousand fuel elements in the core.

The reactor core is shaped either cubical or cylindrical to coolant facilitate the circulation through the core. The core has a series of elements parallel fuel in the form of plates or rods with arrangement for axial flow of the coolant.

Moderator

The core accommodates a neutron moderator which is used to moderate or reduce the neutron speed to a critical value that increase the chances of fission. Chain reaction produces fast moving neutrons which do not effectively cause fission of U²³⁵ and try to escape from the reactor.

To improve the utilization of neutrons their speed is reduced. It is done by colliding them with material having light weight nucleus so that on collision it does not absorb the neutron but

scatters them. Such a material is called Moderator. Three commonly used moderators are graphite, heavy water and 'beryllium'. In fast reactors, moderators are not used.

Coolant System

A coolant is made to flow through reactor core to remove heat produced due to chain reaction and transfer this heat to the feed water for running the steam turbine.

Control System

The control and operation of a nuclear reactor differs from the coal or oil fired furnace where heat energy in the furnace is controlled by regulating the fuel supply. On the contrary a nuclear reactor is loaded with fuel which is sufficient to operate a large power plant for several months.

The consumption of this fuel and the heat generated in the reactor depends upon the neutron flux in the reactor core. The energy produced due to chain reaction in the core is enormous which needs a suitable control, otherwise the entire core and surrounding structure may melt destroying everything followed by radio-active pollution. This situation would be synonymous to atom bomb explosion.

For control of chain reaction 'control rods' of Cadmium or Boron one accommodated in the core which can be raised or lowered for varying the rate of disintegration. Control rods absorb neutrons which are responsible for starting the chain reaction.

Control rods insertion in the core absorbs more neutrons and damps down the chain reaction while their withdrawal absorbs less neutron which

Most of the wind powered electrical generators were displaced as the electric power to the rural area was provided from central power stations through the national grid. Now, because of increasing cost of power, the trend is going to be reversed and again more wind mills be set up to provide the power needs of the rural areas.

Windmills have been used for several countries where high velocity wind is available in abundant quantity. A windmill converts the kinetic energy of moving air mass in to mechanical motion that can be either used directly to run the machine or to turn the generator to produce electricity.

Classification of Wind Power Generators

1. Based on axis

- a) Horizontal axis machines
- b) Vertical axis machines

2. According to size

- a) Small size machines (up to 2kW)
- b) Medium size machines (2 to 100kW)
- c) Large size machines (100kW and above)

Single generator at a single site

Multiple generators

3. as per the type of output power

- a) DC Output

DC generator

Alternator Rectifier

- b) AC Output Variable frequency,

Variable or Constant voltage AC. Constant frequency,

Variable or Constant voltage AC.

4. As per the rotational speed of the aero turbines

- a) Constant speed with variable pitch blades
- b) Nearly constant speed with fixed pitch blades.
- c) Variable speed with fixed pitch blades.

field modulated system

Double output induction generator

AC DC AC Link

AC Commutator generator

Variable speed constant frequency generating systems

5. As per the utilization of output is made

- a) Battery storage
- b) Direct conversion to an electromagnetic energy convertor

c) Thermal potential

d) Inter convention with conventional electric utility 'grids.

Basic components of a Wind Energy Conversion System (WECS)

The main components of WECS are shown in figure 1.20 in block diagram multiple generator form.

Aeoroturbine

Aeoroturbine converts energy in moving air to rotary mechanical energy. In general, they require pitch control and yaw control for proper DC generator operation.

A mechanical interface consisting of a step up gear and a suitable coupling transmits the rotary mechanical energy to an electrical generator. The output of this generator is connected to the load or power grid as the warrants. Gears mounted on the hub to serve as a transmission to increase rotor speed to generator speed. Such a combination offers a high degree of design flexibility as well as large potential savings.

Generator

Either constant or variable speed generators are a possibility, but variable speed units are expensive and / or unproved. Among the constant speed generator candidates for use are synchronous induction and permanent magnet types. The generator of choice is the synchronous unit for large aero generator systems because it is very versatile and has an extensive database. Other electrical components and systems are, however, under development.

Controls

The modern large wind turbine generator requires a versatile and reliable control sy stem to perform the following functions.

- i) The orientation of the rotor in to the wind (azimuth of yaw) in power plant
- ii) Startup and cut-in of the equipment
- iii) Power control of the rotor by varying the pitch of the blades .
- iv) Generator output monitoring-status, data computation and storage
- V) Shutdown and cutout owing to malfunction or very high winds
- vi) Protection for the generator, the utility accepting the power and the prime mover equipment and indicate when and where maintenance or repair is needed.
- vii) Auxiliary and / or emergency power, and The functions of instruments to be performed for

vii) Maintenance mode

Many combinations are possible in terms of the control system and may involve the following components

a) Sensor:

Mechanical, Electrical, or Pneumatic

b) Decision Elements:

Relays, logic modulus, analog circuits, a microprocessor a fluidics, units, or a mechanical unit, and

c) Actuators:

Hydraulic, electric or pneumatic. A recommended combination of electronic transducers feeding in to a micro-processor which, in turn, signals electrical actuators and provides protection through electronic circuits, although a pneumatic slip clutch may be required.

Towers

Four types of supporting towers deserve considerations, there are:

a) Reinforced concrete towers

b) Pole tower

c) Built-up shell-type tower

d) Truss tower

Among these, the truss tower is favored because it is proved and widely adaptable, cost is low, parts are readily available, it is readily transported, and it is potentially stiff. Shell-tube towers also have attractive features and. and may prove to be competitive with truss towers.

IMPORTANCE OF MEASUREMENT AND INSTRUMENTATION

Instruments used in power plants furnish accurate information for guidance to safe, continuous and proper plant operation.

The information given by the recording units from the control room helps to direct its operation so as to achieve the best performance and furnish data for calculation so that results may be compared from time to time. There may be used to check on the internal condition of equipment and indicate when and where maintenance or repair is needed.

The functions of instruments to be performed for

i) Operating Guidance

ii) Performance calculations a











iii) Maintenance and repair guidance

iv) Economical Supervision

v) Pressure and temperature measurements of steam and feed water

ISA Control Diagramming System













INSTRUMENT LINE SYMBOLS

(1) Instrument supply or connection to process	
(2) Undefined signal	
(3) Pneumatic signal	
(4) Electric signal	
(5) Hydraulic signal	
(6) Capillary tube	
(7) Electromagnetic or sonic signal (Guided)	
(8) Electromagnetic or sonic signal (Not guided)	
(9) Internal system link (Software or Data link)	
(10) Mechanical link	

OPTIONAL BINARY (ON-OFF) SYMBOLS

(11) Pneumatic binary signal	
(12) Electric binary signal	

Table 1.1: GENERAL INSTRUMENT OR FUNCTION SYMBOLS

	Primary location normally Accessible to operator	Field mounted	Auxiliary location normally Accessible to operator
Hardware Discrete instruments	1  IPI	2 	3 
Shared Hardware Shared display, Shared control	4 	5 	6 
Software Computer function	7 	8 	9 
Shared logic Programmable logic control	10 	11 	12 

SAMA Control Diagramming System

Table 1.2: Enclosure symbol





Function	Symbol
Measuring or readout	
Manual signal processing	
Automatic signal processing	
Final controlling	

Table 1.3: Measuring / Readout letters

Process variables	Function
A = Analysis**	R = Recording
C = Conductivity	I = Indicating
D = Density	T = Transmitter
F = Flow	RT = Recording
L = Level	Transmitter
M = Moisture	IT = Indicating
P = Pressure	Transmitter
S = Speed	
T = Temperature	
V = Viscosity	
W = Weight	
Z = Position	

*** Self-defining symbols such as O₂, pH, etc., can be used in place of "A".*

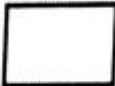
BOILERS OVERVIEW OF POWER GENERATION

Basic Steaming Process

In the conversion of water from its liquid phase to steam (its vapor phase) heat is added to initially increase the water temperature to and leaves the system in the form of steam. The boiling point temperature. This heat raises the temperature of the water is known as sensible heat.

As the conversion from the liquid phase (water) to the vapor phase steam) begins the temperature no longer changes with the addition of heat. The fluid exists at the saturation temperature-pressure relationship during the entire conversion of water to steam.

The heat that is added in converting from the liquid to the vapor phase at constant temperature is called the latent heat of evaporation. Steam that is fully vaporized but has not been heated to a temperature above the saturation temperature is called dry saturation steam. Steam that is not fully vaporized is called wet steam.

By adding additional sensible heat to dry saturated steam, the temperature can be increased above the saturation temperature. Steam that is heated above the saturated temperature is called "Superheated Steam".

Basic Boiler

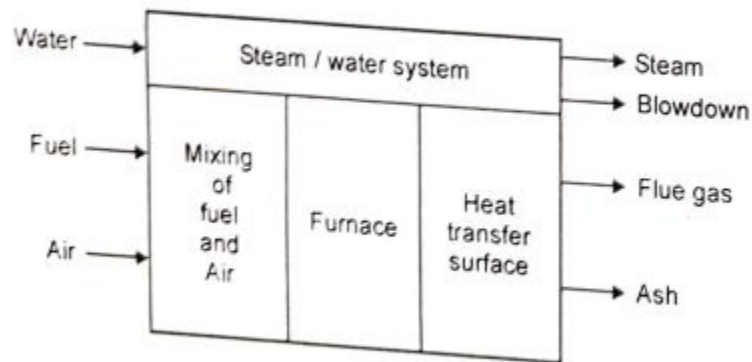

A basic diagram of a boiler is as shown in figure. It comprises two separate systems:

One system is the steam-water system. In to this, water is introduced and, upon receiving heat that is transferred through a solid metal barrier, is heated, converted to steam, and leaves the system in the form of steam.

The other system of a boiler is the fuel-air-flue gas system. This system provides the heat that is transferred to the water. The inputs to this system are fuel and the necessary air required to burn the fuel. In this system the fuel and air are thoroughly mixed and ignited in a furnace. The resulting combustion converts the chemical energy of the fuel to thermal or heat energy.

The furnace is usually fixed with heat transfer surface in the form of water-steam circulating tubes. These tubes receive heat radiating from the flame and transfer it to the water-side-system.

The gases resulting from the combustion, known as the flue gases, are cooled by the transfer of their heat by what is known as the radiant heat transfer surface. The gases leave the furnace and pass through additional heating surface that is in the form of water-steam circulating tubes. Thus heat transfer cools the flue gases, which then leave the boiler.

The factors affecting this time constant include the system heat storage, the heat transfer coefficients in different parts of the system, the masses of metal and refractory and their configuration, and various other factors.

Boiler Types and Classification

There are two general types of boiler

- a) Fire tube boiler
- b) Water tube boiler

In addition, boilers are classified as

- a) High pressure boilers
- b) Low pressure boilers
- c) Steam boilers
- d) Hot water boilers

High Pressure boilers operate at a pressure greater than 15 psig when the boiler water temperature rises as the pressure is increased; the flue gas temperature is increased.

A particular attribute of high pressure steam is that it contains a significantly greater amount of available energy that is available to be converted to work in an industrial or electric power generation steam engine chamber Feed or turbine.

Low pressure boilers operate at a pressure lower than 15 psig. Almost all low pressure boilers are used for space heating. Low pressure boiler systems are simpler since pressure-reducing valves are seldom required and the water chemistry of the boiler is simpler to maintain.

Hot water boiler is essentially a fuel-fired hot water heater in which sensible heat is added to increase the temperature to some level below the boiling point.

High Pressure Boilers

When steam is needed at pressures, 30 Kgf/ cm² and individual boilers are required to raise less than about 30 tons of steam per hour, shell boilers are considerably cheaper than water tube boilers, and are equally satisfactory in all other respects. Above these limits, shell boilers (generally factory built) are difficult to transport if not impossible. There are no such limits to water tube boilers.

a) La Mont Boiler

A forced circulation boiler was first introduced in 1925 by LA MONT. This is generally used in Europe and America. The arrangement of water circulation and different component is shown in figure.

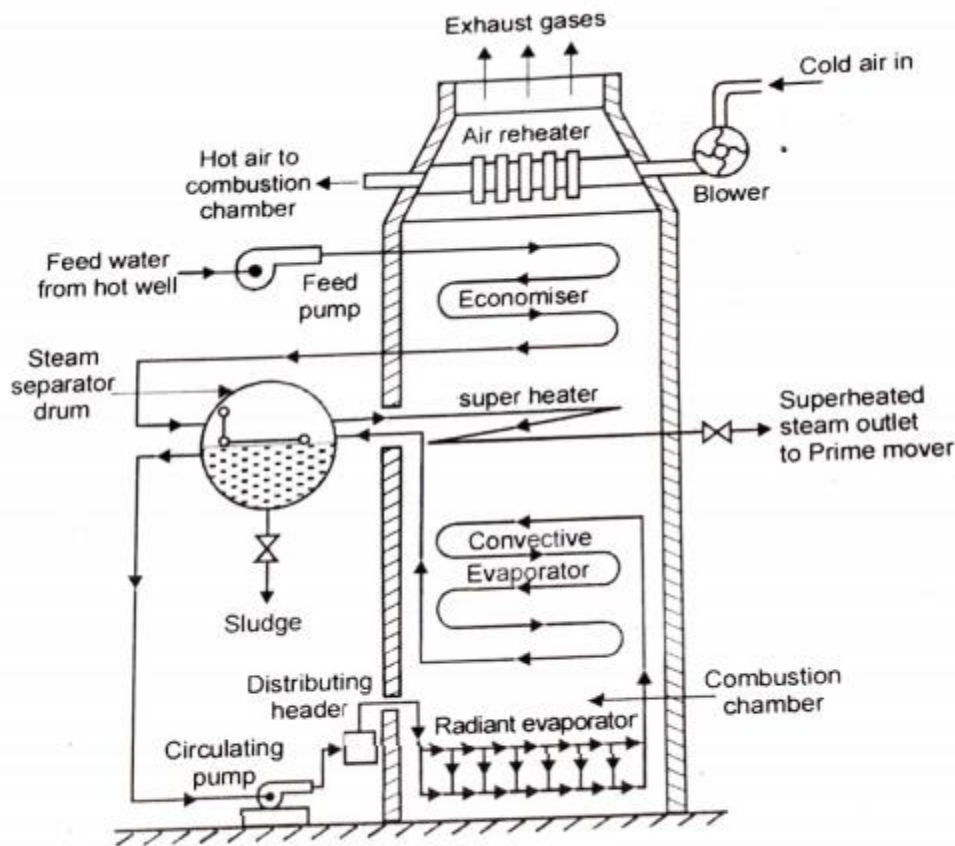

La mont boiler

The feed water from hot well is supplied to a storage and separating drum (boiler) through the economizer. The most of the sensible heat is supplied to the feed water passing through the economizer.

A centrifugal pump circulates the water equal to 8 to 10 times the weight of steam evaporated. This water is circulated through the evaporator tubes and the part of the water evaporated is separated in the separator drum. The large quantity of water circulated (10 times of evaporation) prevents the tubes from being overheated.

The centrifugal pump delivers the feed water to the headers at a pressure of 2.5 atm. above the drum pressure. The distribution headers distribute the water through the nozzles in to the evaporator. The steam separated in the boiler is further passed through the super heater and

finally supplied to the prime mover. To secure, a uniform flow of feed water through each of the higher size units with higher steam parameters seem a natural choice for economical installation and operation of thermal power plants. The 800 MW units would be designed on supercritical steam pressure with a drum less boiler on once through principle.

With increasing pressure of steam, the differential between the specific weight of saturated water in down-comers and specific weight of steam-water mixture in furnace wall tubes (which causes natural circulation in boiler) circulation boiler. goes on decreasing.

Sluggish circulation causes film boiling. In film type boiler, the tube metal remains in contact with steam bubbles which provide high thermal resistance for heat flow and therefore tube metal sharply deteriorates due to high metal temperature leading to boiler tube failures.

For pressure above 180 bar with natural circulation as shown in Fig, it is not possible to prevent "film boiling" in the upper furnace tubes. Therefore, generally, above 150 bar pressure, controlled circulation in water walls is used by providing boiler circulating pump between down comers and lower water distributing heaters and the water walls.

In controlled circulation boilers as shown in figure, it is possible to utilize high steam pressure up to 200 bar but beyond this, there is a reduction in the effectiveness of Boiler Drum in separating the saturated Vortex shedding Super heated steam to turbine O Steam drum FW steam from water.

Therefore, beyond 200 bar, a drum less boiler is envisaged. A Separator Vessel is utilized to separate out salts from steam water mixture in sub- critical range (225.65 bar), the separator vessel cannot function and only once through (mono tube) is adopted. Various manufacturers have adopted different techniques.

Sulzers Brothers Ltd. has adopted Separator Vessel in their design as shown in figure with sub-critical pressures and there are no boiler circulating pumps. The once through circulating is provided by feed pump.

H/S Combustion Engineering Company have adopted a "Mixing Vessel" which provides suction to boiler circulating pumps at sub-critical pressures, provides suction to boiler circulating pump and inlet saturated steam to superheater and serves as a receiving header for steam-water mixture from evaporator suction as shown in figure. The boiler circulating pumps are required to function in the start-up or low pressure conditions but when the pressure goes above critical pressure then these are stopped and once through circulation is provided by boiler feed pump. This is called a combined

PIPING AND INSTRUMENTATION DIAGRAM OF BOILER

Using ISA control diagramming system or SAMA control diagramming system, all the process variables are measured and transmitted to a controller for control action in the final control element figure. Shows the piping and instrumentation diagram. Air has taken for combustion process through forced draft fan across Air heater. The temperature of the air is transmitted by temperature transmitter (TT) and the flow is measured by differential pressure measurement by flow transmitter (FT). Depends upon the load, the fuel is supplied from the pulveriser through mass flow meter (FT) and it is controlled by a flow controller (FC).

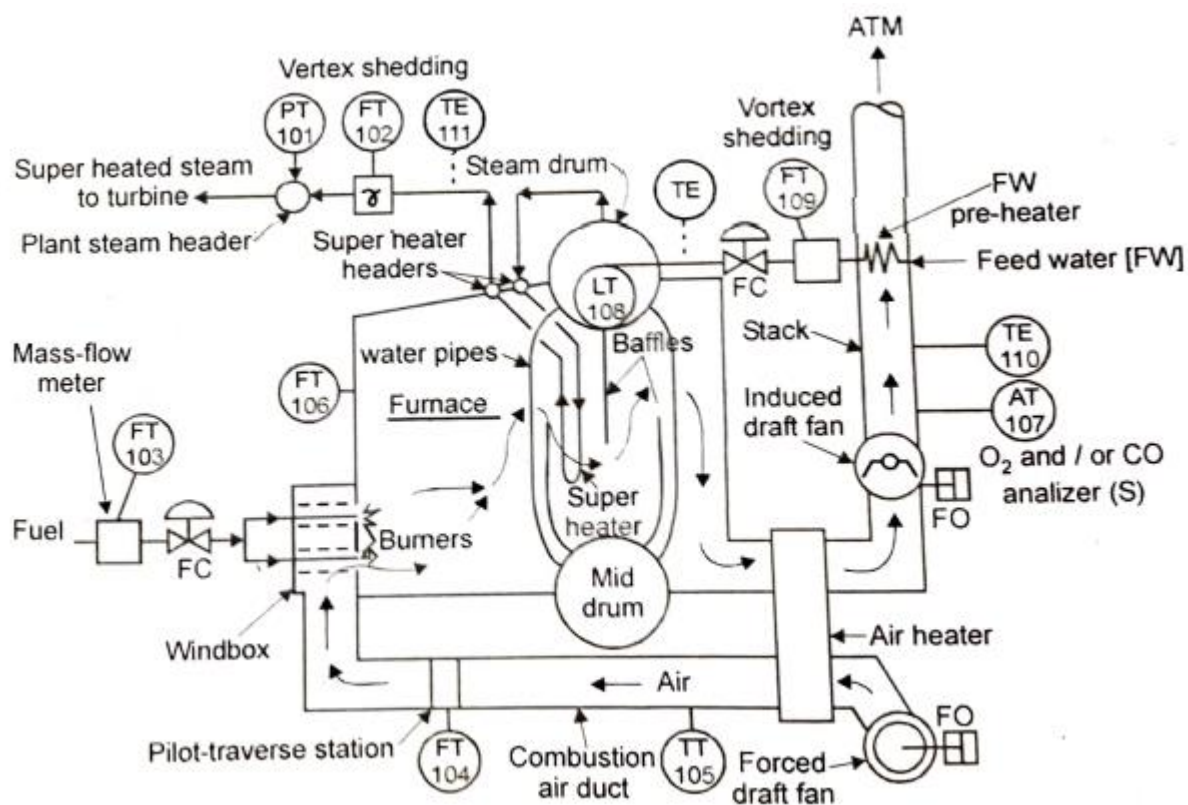

In the boiler furnace, temperature is measured at the sides and the middle by temperature transmitters (TT). Drum level is measured in the steam drum and mud drum by using level transmitter (LT). Feed water supplied to the steam drum after deaerated through Economizer with at is favorable towards combined production of thermal and mechanical energy. Controlled flow using flow controller (FC).

Temperature of the steam is increased by adding additional sensible heat to dry saturated steam, the temperature can be increased above the saturation temperature for the production of super heated steam. The pressure and temperature of the superheated steam is measured by using pressure transmitter (PT) and temperature transmitter (TE). Finally the super heated steam is passed in to the prime mover with controlled flow, pressure and temperature.

From the boiler, because of combustion process the flue gas is taken out through the stack and its temperature is exchanged to feed water and to the air input, the corresponding temperature is measured by temperature transmitter. The dust and ash is collected by the use of Ash collector. A pollution monitoring instrument is used for the measurement of pollutant (AT) in the flue gas.

CO-GENERATION SYSTEM

Co-generation is the combined production of two forms of useful energy from the same fuel. In industry, two forms of required useful energy are to condensate thermal and electrical.

Co-generation systems are sequential in nature because the exhaust from producing one form of energy is used as input for producing the next form of energy

In co-generation system, high pressure steam is used for generating & the power and the exhaust steam is used in manufacturing processes. Efficiency of co-generation system is as high as 85% whereas the efficiency of steam power plant is hardly 40%

The higher efficiency in the conversion of fuel in to useful. Translates in to a substantial reduction in pollution and reduction in the energy costs associated with production operations.

Co-generation is most often used in industrial units requiring significant amounts of thermal energy and electricity and where the ratios of the two forms of energy are favorable towards combined production of thermal and mechanical energy.

There are two types of co-generation systems as:

- i) Topping Cycle
- ii) Bottoming Cycle

In topping cycle, shaft power is first developed as shown in Fig.1.26 b d and the exhaust is used for supplying thermal energy. Whereas, in bottoming K cycle, the sequence is reversed as shown in figure.

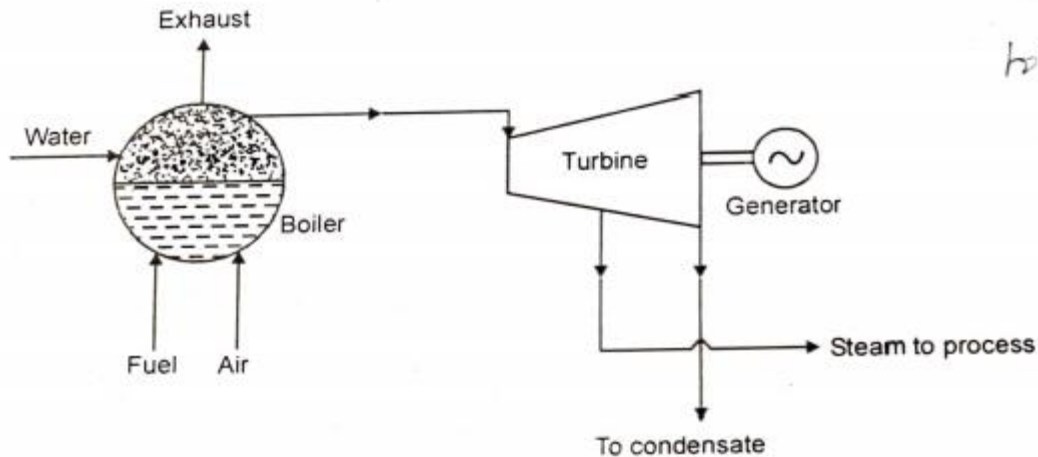

Topping cycle is often used when temperatures and pressures for a given industrial process are relatively low. Bottom cycle is typically feasible when the temperatures of process waste system are relatively high. Form of energy. The important benefits of co-generation are reduction in the overall energy cost. These savings, combined with the benefits of minimal operating and maintenance costs and high reliability of the components can lead to an overall positive cash flow.

i) Energy saving of 0.3kg / kWh of coal is possible using co. generation.

ii) Capital cost will be reduced from Rs,2 Crore / MW to Rs.1 Crore/ MW with the use of co-generation

Nearly 2000MW co-generation potential has been identified in Indian industry and it is worthwhile to adopt co-generation wherever possible as it has low capital cost and low running cost also.

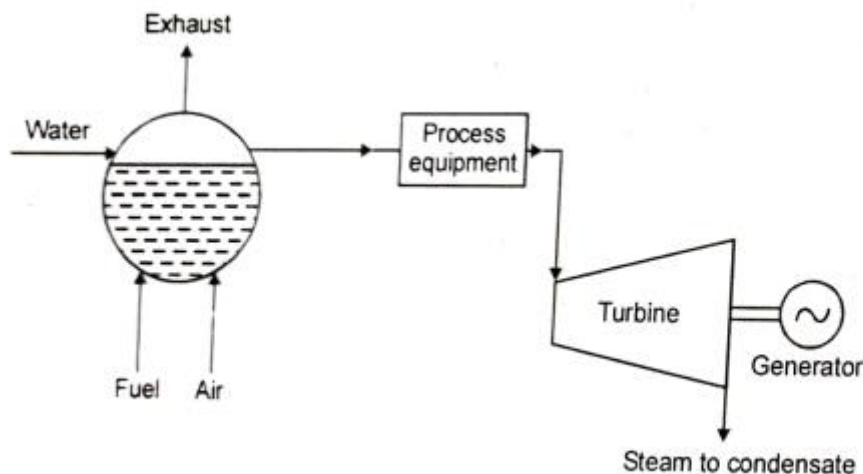

Combined cycle systems

Generator This is generally used to increase the overall efficiency of the gas turbine cycle as the efficiency of basic gas turbine cycle is considerably low (20 to 25%).

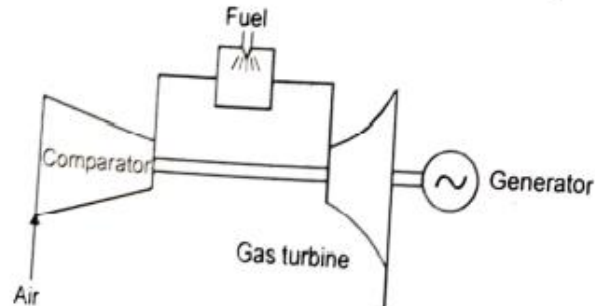

Different modifications over the basic gas turbine cycle to improve the thermal efficiency of the plant are shown in figures shows the modifications to use the heat in the exhaust of gas turbine to improve the overall efficiency of the plant.

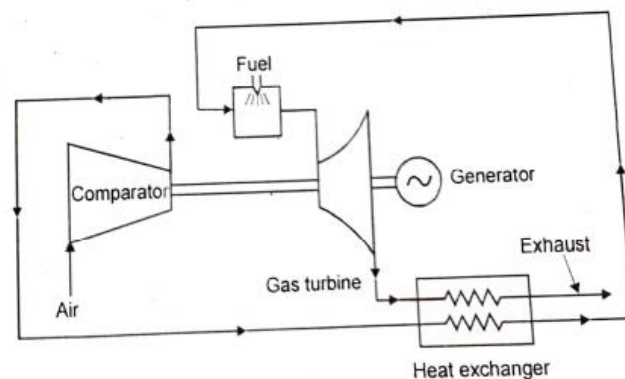
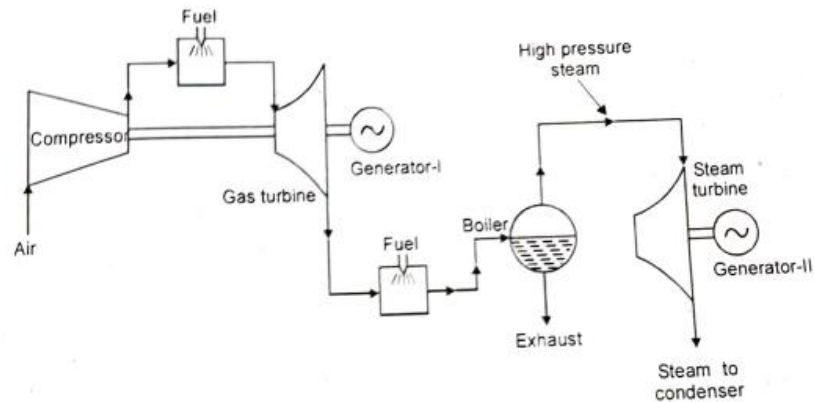

Shows the arrangement for co-generation where the Air Exhaust heat is used for steam generation which is used further for process plant.

UNIT – II

Measurements in Power Plants

MEASUREMENT OF AIR FLOW, STEAM FLOW AND FEED WATER FLOW

Methods of Flow Measurement

- a) Pressure difference method
- b) Displacement method
- c) Inferential method
- d) Non-Inferential method

Method a) is used for all main flows of steam and feedwater.

Methods b) are used for ancillary flows and for oil flow to burns of oil-fired boilers.

Elements used for Flow Measurement

- i) Orifice plates
- ii) Nozzles
- iii) Venturi tubes
- iv) Dall tubes

Differential Pressure Measurement of Air Flow

i) Measurement of Combustion Air Flow with Orifice Segment in Duct One potential primary device is an orifice segments in the forced draft duct, figure. shows this type of device. It is simple to design and install but its drawback is lower pressure recovery and thus greater permanent pressure drop. Considering the individual nature of the ductwork, an accurate design is impossible. An approximate design combined with field calibration can produce good results.

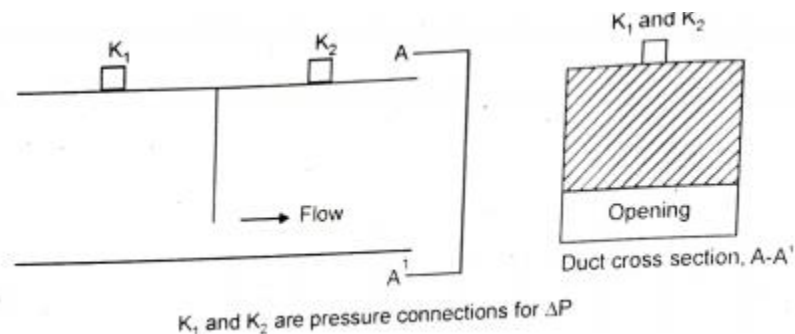

Measurement of Airflow with Orifice Segment in Duct

An approximate design can be made by considering the duct as a round duct and designing an orifice plate in a standard manner(The d/D (orifice diameter/pipe diameter) is then converted to an area ratio (a/A) ,) which will be the square of the d/D ratio.

Using the area ratio, the opening area can be determined. This area is subtracted from the duct cross-section area to yield the area of the orifice K_1 and K_2 Duct cross section, C

Measurement of Combustion Air Flow with Venturi Section in Duct

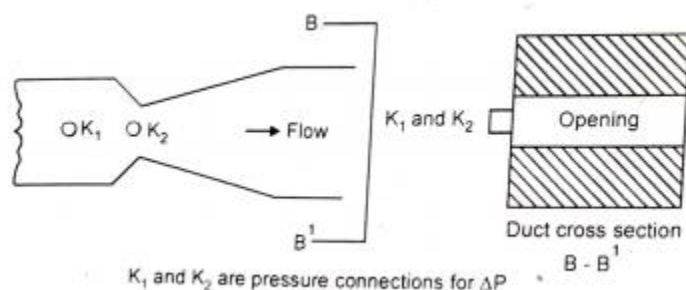

Measurement of Air Flow with Venturi Section in Duct

In order to reduce the permanent pressure loss of the measuring device a venturi-type duct segment, as shown by figure, can be installed. The design of such a duct segment should be undertaken only by someone with good design basis information, such as a boiler manufacturer.

This does not assure good design, however, since a design of 2 inches of H₂O differentially yield an actual differential pressure of 8 inches of H₂O. A recalculation confirmed the original design.

Measurement of combustion Air with Air Foil in Duct

Further reduction in permanent pressure loss can be obtained by using an air foil design, as shown in figure. The design of an air foil also requires background of such a design along with empirical data that is based on the actual results of previous air foil designs.

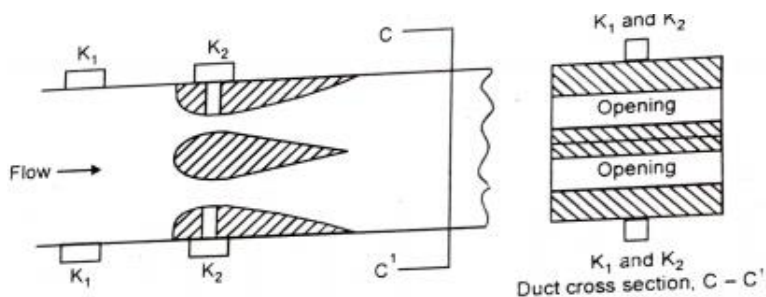

Measurement of Air Flow with Air Foil in Duct

Air foil designs are usually made by boiler manufacturers. A primary device of this type is also somewhat less expensive to construct than the venturi duct section.

Measurement of Combustion Air flow using Differential Pressure across a Tubular Air Preheater

Another technique that requires no additional power consumption is to use the pressure drop across the boiler parts.

One method is the use of the pressure drop across the air side of a tubular air preheater as shown in figure. There are usually 2 (or) more inches of HO available at full boiler load.

In most such air preheater arrangements, the difference in elevation between the pressure connections requires compensation for the chimney or stack effect due to the difference in temperatures.

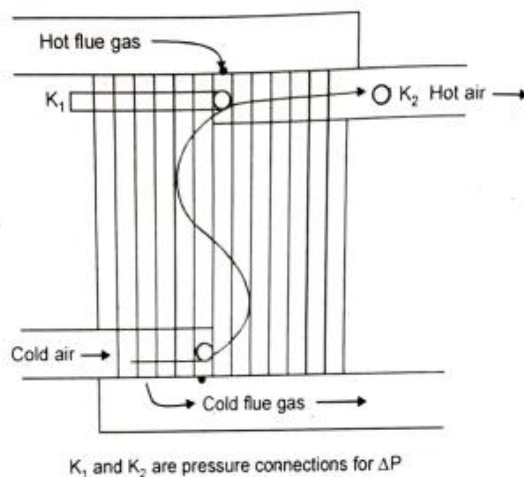

Measurement of Air Flow using Differential Pressure across a Tubular Air Preheater

The method of connection shown in figure will usually provide the Hot wire necessary compensation

Inferential Measurement of Combustion Air Flow

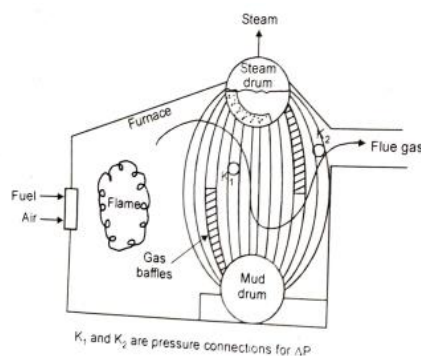

Inferred Measurement of Combustion Air Flow by Pressure Drop across Baffles in Flue Gas stream Figure shows this method, which uses the pressure or draught O K, Hot air > differential across the boiler tube passes. The use of such a measurement tends, however to produce a greater interaction between the fuel and air flow control loops.

A further disadvantage is that such an air flow measurement is affected by soot or other foreign deposits on the boiler tubes. Another disadvantage is the unavailability in many elevation of the pressure connections is used to compensate for (the "Chimney" effect that results from temperature difference of the flue gases at the two measurement points).

Non-inferential Method of Air Flow Measurement

HOT WIRE ANEMOMETER in the flowing fluids. Due to the change in the velocity of flowing fluid, the heat lost by the hot wire will also change. A relation between this loss of heat the basic system consists of an electrically heated wire suitably mounted and the fluid flow can be desired.

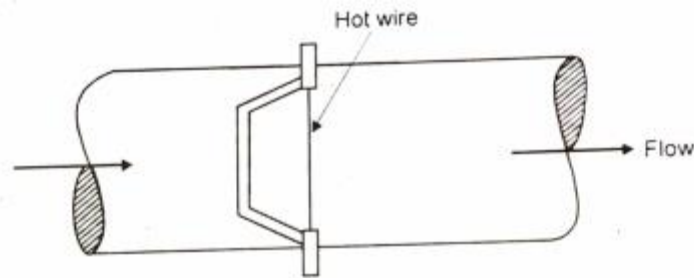

The setup of the Hot Wire Support

This heat loss changes the temperature and as a consequence resistance of the hot wire changes. This generally changes the current through the hot wire for a constant voltage supply. Measuring the change in the resistance or in the current the flow can be found out. There are two basic techniques of Flame Air Gas baffles drum Mud measurement of flow.

- i) By measuring resistance keeping the current constant.
- ii) By measuring the current keeping the temperature constant i.e., Pressure Drop across Baffles in Flue Gas stream resistance constant.

The thermo element is generally made of platinum wire having diameter of 0.0005 to 0.03 Cm and a length of 0.1 to 1 cm depending on the flow channel diameter. The axis of the hot wire is perpendicular to the direction of flow. The heat from such a wire to the fluid is obtained.

$$I^2 R_w = k(t_w - t_g) h a$$

where k - Conversion factor, t_w - Wire temperature
 t_g - Fluid temperature, I - Current through the wire
 h - Film coefficient of heat transfer, a - Heat transfer area

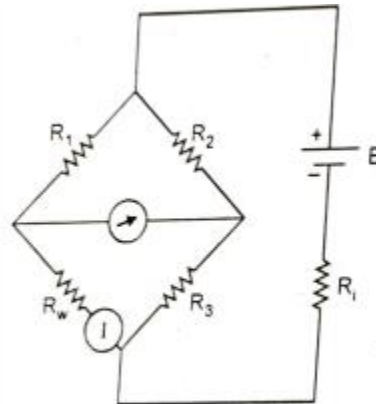

Bridge circuit

The bridge circuit with appropriate supply and detector is used for measurement purpose. In the constant current type the circuit is as shown in figure . Where R_5 is a large resistance and R_1, R_2, R_3 , and R_4 is of the same order as that of R_5 .

OIL FLOW MEASUREMENT

Vortex Flow Meter Flow

For oil flow measurement in recently constructed power stations, the rotating vortex type of flow meter is being installed as illustrated in figure the vortex-velocity principle involves a vortex pool which has a clearances circular motion from and drives a multi-bladed rotor. The rotor, which has ample the meter body is only used to count the vortex by means revolutions of the of a magnetic coupling to an integrating mechanism

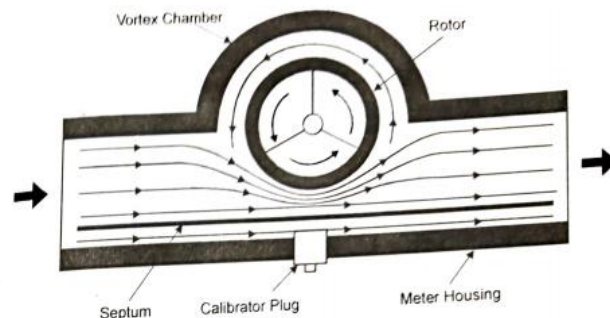

Vortex Velocity Principle

Solids entrained in the fluid do not affect the operation and very little wear occurs, the bearings being purged with clean oil or appropriate fluid from an external supply.

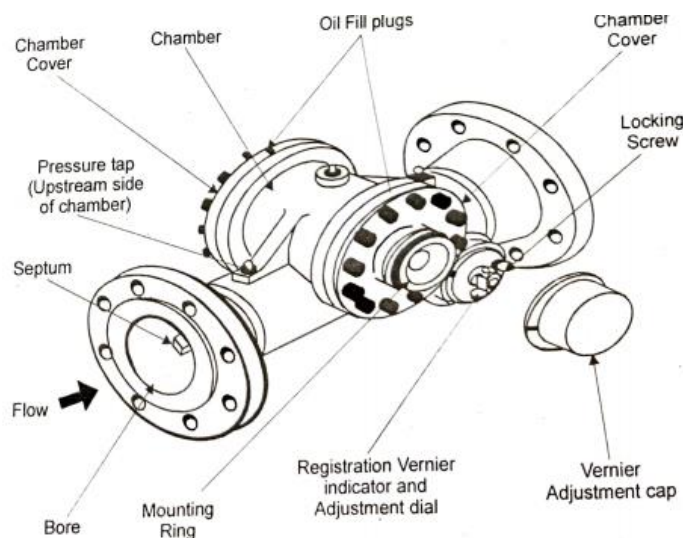

Vortex Meter

The error is specified as within 0.5% over a 10:1 span, but with a "prover loop" on which the flow measuring device can be periodically calibrated, it is expected that the error can be kept within + 0.2%.

Figure is normally required. Illustrates how the vortex meter is housed in a special pipe section provided with flanges which are connected to the pipe work arranged for straight lengths of 10 diameters upstream and 5 diameter downstream of Blow down cocks the vortex meter.

The integrating meter can be replaced at any time, whilst the rotor assembly can be replaced without dismantling the pipework provided that Slope not less than 1:10 Air vessels the oil has been drained.

(The method of using a "prover loop" is shown in figure and this consists of a transportable U-section the diameter of which is known precisely and in which a plastic ball is accommodated) shown as a block dot at A. The loop is connected to branches on the pipework. So that the oil can flow through the loop and vortex meter in series.

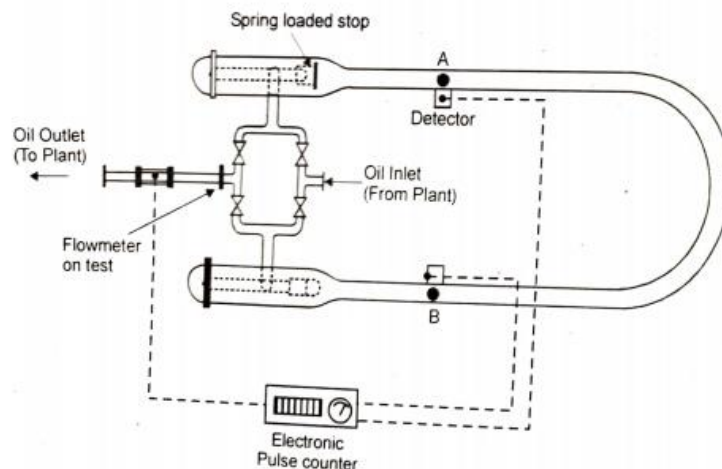

Meter Prover Loop

Electronic timers at the two ends of the loop measure the time taken for the plastic ball to move a known distance from A to B; and the swept volume can be calculated. The diagram is over simplified, as arrangements are provided for returning the ball to A for repeat tests, so as to obtain an average flow rate in gal/sec. A density correction has to be used for conversion to klb/h. Figure is normally required.

MEASUREMENT OF STEAM FLOW

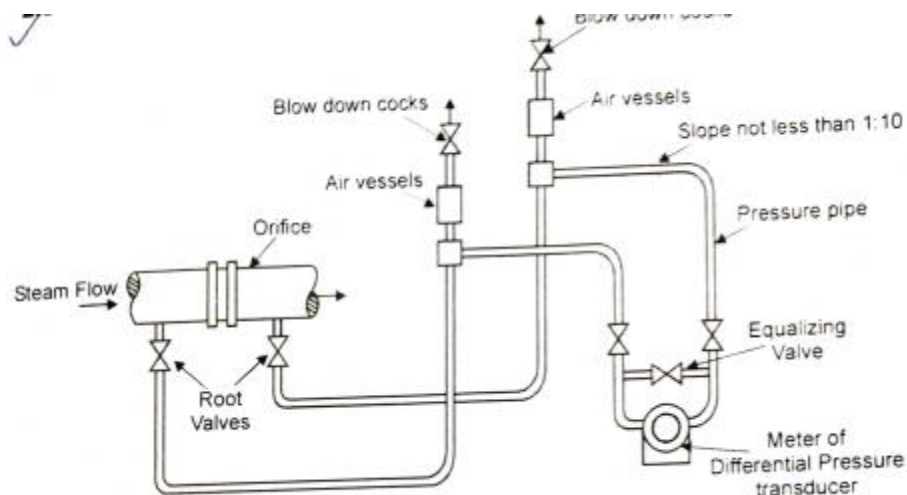

Steam flow measurement

It consists of a differential transducer located below the level of the main or pipeline (laid horizontally) in which the orifice is installed. (Pressure pipes fall continuously from orifice to meter at a slope of not less than 1/10 as shown in figure 2.11.

If the horizontal distance is too great to allow this slope by direct connection between orifice and the meter, then pressure pipes may first be taken below the meter and then raise to the meter. If, however, the bends above the pipeline can't be avoided, then air vessels with vent cocks should be filled at the highest points and these must be vented and drained as frequently as is necessary to prevent them from filling with air.

The special requirement for steam metering is necessary of interposing cooling chambers for the purpose of condensing the steam and providing an adequate volume of water for supplying the meter displacement at all variations of load.

STEAM PRESSURE MEASUREMENT

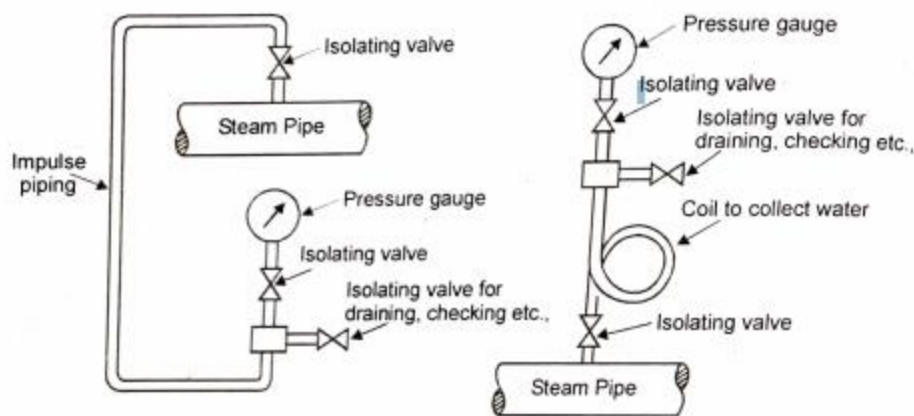

Steam Pressure Measuring Equipment

To measure the steam pressure, the pressure, take-off pipe should be at the top of the main pipe and should be fitted with a suitable isolating valve drained, as shown in figure .

The connecting impulse piping to the pressure gauge must be of ample strength and a water seal must be provided so that the steam does not directly rush to the Bourdon Tube. The water seal can be provided either separately or as part of the pipe.

If the gauge is below the level of the steam pipe, water will form and protect the gauge and Bourdon tube. In case gauge is above the steam pipe, coil a to collect water must be provided in the impulse piping near the pressure gauge.

An isolating valve is fitted at the gauge end of the impulse piping, so that the gauge can be changed whilst the steam is flowing in the main pipe

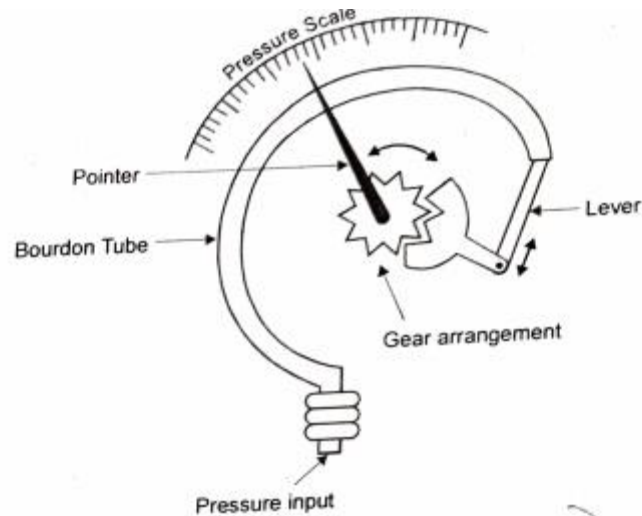

Bourdon Gauge

In this case, in laying of the steam is flowing in the main pipe. In this case in laying of the impulse pipe, formation of loops, in which air or vapour can collect should be avoided. When the pressure medium is air or gas, the pipe should rise continuously to the gauges, so that any moisture can be drained.

In order to test the bourdon gauge in-situ, it may be necessary for certain important gauges to have a T-connection with an additional isolating valve to which the check gauge can be connected while the steam continuous to flow in the main pipe.

MEASUREMENT OF HIGH PRESSURES

The pressures in the range of 650 kg/cm²* to 16500 kg/cm² are considered to be as high pressures. The conventional pressure measuring devices, such as strain gauge pressure cells, Bourdon tubes etc. are considered to be suitable for measurement of pressures as high as 3300 kg/cm² to 6600 kg/cm².

The Bourdon tubes for such applications are quite stiff and the deflection per unit is quite small. They are made of round cross-section having high ratio of wall thickness to diameter and are usually made of a number of turns.

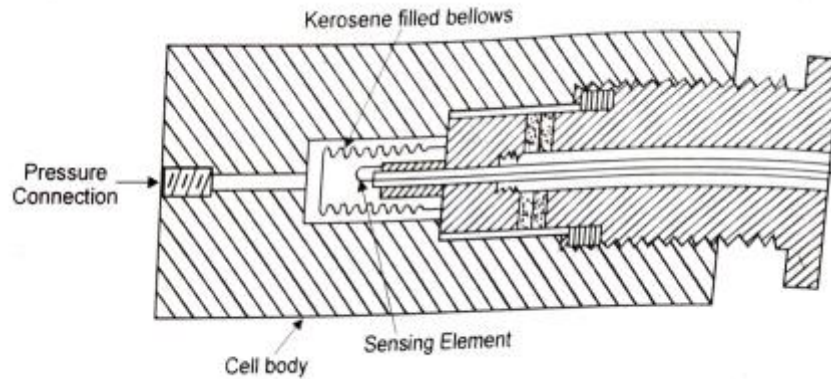

Bulk Modulus Pressure Gauge for High Pressure Measurement

Very high pressures of the above order can be measured by electrical resistance pressure gauge. In such gauges, the bulk compression effect is utilized to change the electrical resistance.

In other words, these gauges make use of the resistance change brought about by direct application of pressure to the electrical conductor itself.

The sensing element consists of a loosely wound coil of relatively fine wire and does not actually contact the process medium, but is separated there from by a kerosene-filled bellows. Thus the bulk compression effect of the pressure results in an electrical resistance change which is calibrated in terms of the applied pressure.

Based on its principle of working, this type of gauge is also known as bulk modulus pressure gauge. The section of such a gauge is shown in Figure.

STEAM TEMPERATURE MEASUREMENT

The part of a thermometer which senses the change in temperature sometimes is called the thermometer element. This element is thermometer inserted in to a pocket which must be carefully designed and installed with due regard to the working pressure in the pipe at high temperature and pressure.

In order to prevent heat transfer from the hot body the thermo well should conduct heat readily at the tip as well as axially. The thin wall of the well (thermometer pocket) also reduces time lag in the response or thermometer.

The base i.e., the top of the well should protrude out beyond the wall of the pipe in order to prevent flow of heat along it and the wall of the pipe should be properly insulated around the measuring point.

In case there is some space left out between the outside of testing body Cell body and the well, it must be filled with proper filling substance (stab) which will not evaporate or burn at the measuring temperature.

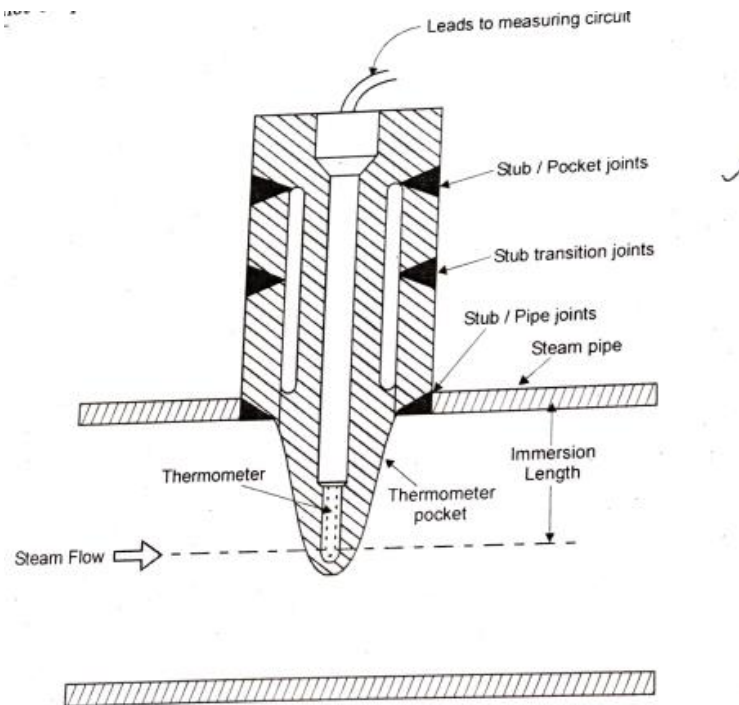

Steam temperature measurement

In certain cases, the resistance elements or the thermocouple leads dully mounted in the proper hot wells (protecting tubes) which are threaded outside and these can be simply inserted in to the steam pipe by providine the necessary stubs on the pipes

BODLER STEAM DRUM

Saturated Steam Moisture Elimination

The steam that is collected in the steam drum contains some droplets of boiler water that must be removed before the steam is delivered from the drum figure demonstrates in a general way how the water and steam are separated

As the steam-water mixture raises to the drum, internal baffles separate this mixture from the water that goes on to recirculation through the down comer tubes. The steam is liberated from the mixture and collects in the upper part of the drum. Before passing out of the drum, the stream passes through mechanical separation devices.

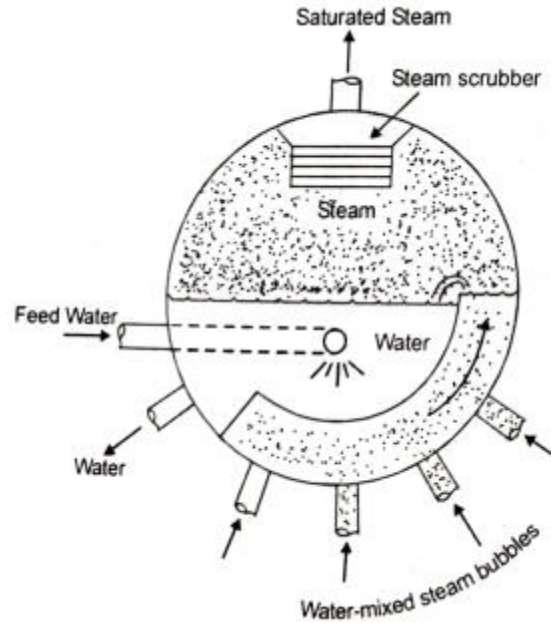

Boiler Steam Drum

These "Scrubbers" or Separators", which may be of many different designs, return the moisture droplets to the water in the drum and allow dry re steam to pass out of the drum. The most sophisticated of these separators uses a centrifugal action that whirls the mixture with the steam emitted from the center and the heavier water from the outside. When very dry steam is required, many of these devices will be found inside the drum along with simpler scrubber equipment. While it is not evident from the outside the inside of the drum is often filled with such devices.

After passing through the scrubbing devices for eliminating moisture droplets, the steam leaves the drum. If the boiler has no super heater, the steam flows to a distribution header. All boilers feeding such a header must have a non-return valve at the boiler outlet. If the boiler has an integral superheater, the steam will pass through the super heater before it leaves the boiler.

Drum Level Measurement

The basic indication of the drum water level is that shown in a sight gage glass connected to the boiler drum. The typical arrangement is shown in figure. Since the configuration of the boiler and the distance of the boiler drum from the operator may not provide a useful "line-of-sight" indication, the gage-glass image can be projected with a periscope arrangement of mirrors, so that the operator may easily view it.

In many installations, the use of mirrors to project the water level image to a desired location for viewing may be necessary. One such method is to use closed-circuit television. Yet another is the use of a remote level indicator based on fiber optics.

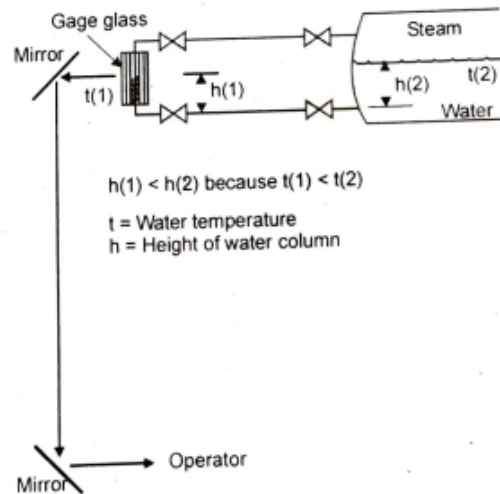

Gauge Glass Drum Level Indication

While the gage glass is the basic measurement, the indication it provides usually is in error to some degree and is not as correct as a properly calibrated level measuring instrument. The basis for the error can be recognized from Water figure .

Condensate from cooling boiler steam circulates through the gage-glass. This cooling of the steam and its condensate results in cooler water in the gage glass than in the boiler drum. The greater density of the cool water in the gage glass then shows a lower height water column to balance the column of water in the boiler drum.

Assuming a typical industrial boiler, the gage glass reading often reads 1 to 3 inches of water below the actual level in the boiler drum/ The deviation depends on the boiler pressure and the ambient temperature, plus piping and insulation between the boiler drum and the gage glass.

For large height pressure electric utility boilers, the difference may be 5 to 7 inches. This may be in the mechanical design or the potential for moving the gauge column closer to the drum.

When this fact is sufficiently understand, most of the error can be eliminated by physically lowering the gage glass. This potential for error must be well understand by anyone dealing with boiler drum level measurement and control, or much unproductive work may be performed in trying to make a gage glass and measuring instrument agree.

These types of drum measurement errors should not be confused with drum level measurement differences between the two ends of the drum. Because of water circulation induced lateral flows inside the boiler drum, such differences are common.

On large electric utility units, differences of six or more inches may be observed. In some cases, the higher measurement may be at one end of the drum at low boiler loads and at the other end at high flows.

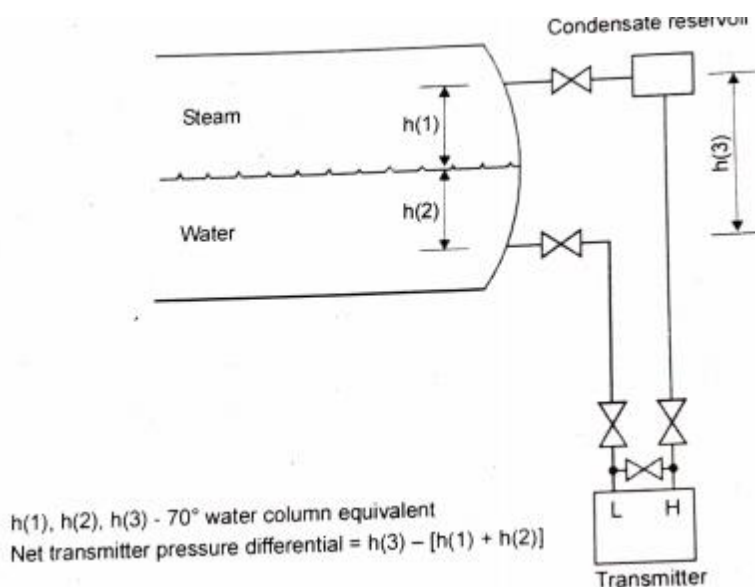

Drum Level Transmitter-Connection and Calibration

A typical arrangement of a drum level measuring transmitter is shown in figure. The transmitter is a differential pressure device in which the output signal increases as the differential pressure decreases. Typically, the differential pressure range is approximately 30 inches with a zero suppression of several inches.

To determine the measuring instrument calibration, the necessary design data are the location of the upper and lower pressure taps in to the boiler drum with respect to the normal water level (NWL), the operating pressure of the boiler drum and the ambient temperature around the external piping.

In addition, with long pipe connections to a remote indicator there is a time lag due to the small head change in relation to the inertia of the liquid in the two columns.

For the reasons mentioned, it is necessary to avoid long pipe connections and to arrange for these to have, a continuous fall from drum to diaphragm so as to avoid air bubbles which can seriously impair accuracy. As the indicator is connected direct to the boiler drum, the diaphragm has to be located in a safe position, usually just below the drum. For boilers on 500 MW plant, either diaphragms or bellows are used to sense the level and these are provided with telemetering equipment so that an electrical instrument can be used in the control room for boiler water level indication. One of these is a mercury manometers and the other a bellows or diaphragm operated manometer. In the former the movement of a float or bell is applied to an electrical transmitter or a resistance-change element in the low-pressure limb may be used for this purpose. With the

latter, a bellows or diaphragm, is opposed by a control spring and the mechanical movement converted in to an electrical signal.

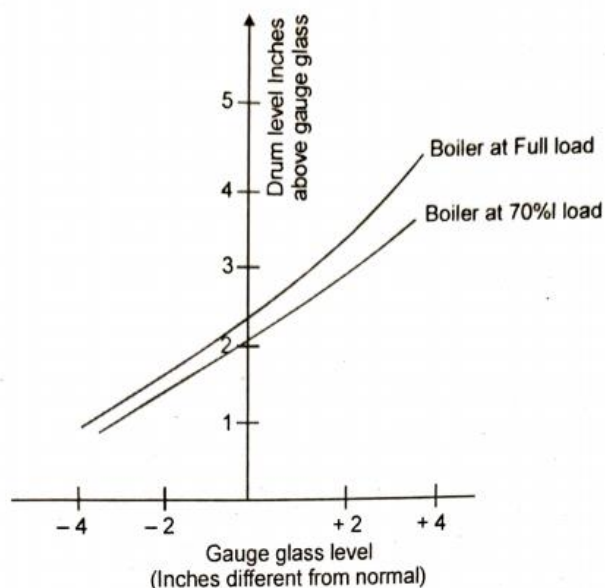

Errors in boiler water level gauge readings

SMOKE MEASUREMENT

The Ringlemann Chart

The emission of smoke from industrial premises has been brought under control of the "Clean Air Act" and the assessment of smoke emission to comply with this Act is based on the use of a chart which has fire areas representing shades of grey. This is known as a Ringlemann chart, the darkness of the smoke being compared with the shades of grey shown on the standard chart which has been prepared by the "British Standards Institution". A facsimile of the standard Ringlemann chart is shown in figure from which it will be observed that the shades of grey are produced by squares with different thickness of black lines on a white background so that a known percentage of white is obscured.

When making an observation of the darkness of smoke the Ringlemann chart is placed at such a distance from the observer that the black lines merge to give appearances of shades as Ringlemann numbers, range from 0 (all white) to 5 (all black) in steps of 20% obscuration of the white background.

The legal requirement is that the darkness of the smoke must correspond to less than Ringlemann 2 (40% obscuration), although this is the criterion for dark smoke emission, the chart is only of practical use for spot checks, The more usual method is by continuous recording smoke density instruments, commonly referred to as smoke meters.

RINGLEMANN CHART

<i>Number</i>	<i>Description</i>	<i>Percentage of Black on shade card</i>
0	No smoke	0
1	Light Grey	20
2	Darker Grey	40
3	Very Dark Grey	60
4	Black	80
5	Dense Black	100

Facsimile of Ringlemann Chart

Smoke Meters (Photocell Type)

The principle is the same for all type of smoke meters, the passing of a focussed light beam through the duct or chimney on a photocell. Variations in the signal of the photocell circuit will be a measure of the variation of the obscuration of the light source due to the smoke and dust in the gases.

The indicator will be scaled in percentage obscuration. This is the obscuration of light due to the smoke in the duct which is not necessary the same as the apparent obscuration caused by the smoke issuing from the chimney, when viewed against the sky and referred to as a Ringlemann number.

From work at "Warren Spring Laboratory" (Ministry of Technology), C.E.R.L (Central Electricity Research Laboratory) have calculated that for average conditions 64% obscuration as shown by the smoke meter corresponds to Ringlemann 2.

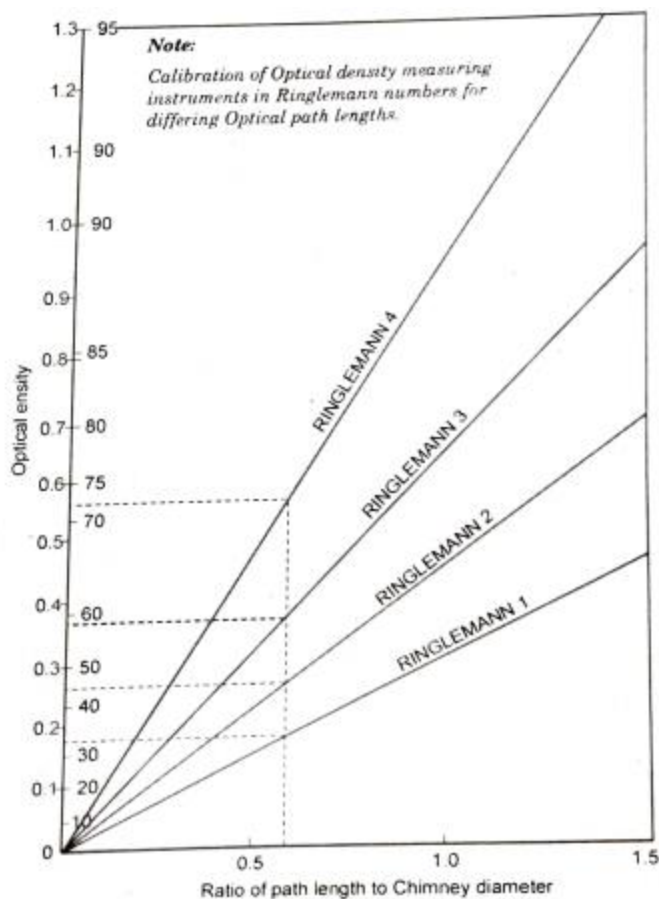

Effect of differing optical path lengths

This relationship, however only applies when the Length of: path of the smoke meter is equal to the diameter of the chimney top. A correction graph showing the relationship when the light path differs from the chimney diameter is given in figure which is taken from a C.E.R.I. Report.

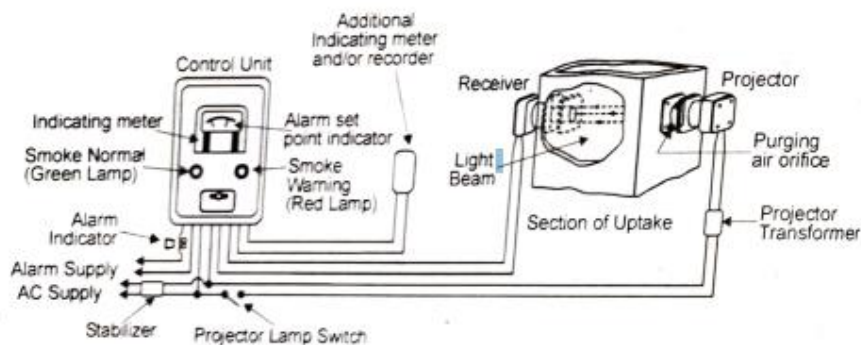

Optical-Type Smoke Meter

A smoke meter equipment consists of a stabilized power supply, a lamp and projector mounted on one side of the duct, a receiver fitted with a photocell, which may be of either selenium or cadmium sulphide type on which the light is beamed, mounted on the opposite side of the duct, a control unit with indicator, warning lamps, alarm and recorder as shown in figure.

The "Everclean" Window

Fouling of the projector and receiver lenses by smoke and dust has always been a problem with smoke meters and various methods for overcoming this have been introduced from time to time. The "Everclean" window is the most successful of these devices and is now in general use.

The principle of the "Everclean" window is that dust will not be deposited at the end of the tube at right angles to the duct length to the ratio of the diameter is at least 4:1 for the coarser particles and 16:1 for the finer dust and fumes.

If, therefore, the lamp and photocell units be mounted on extension tubes of adequate length, the lens windows are likely to remain clean for lengthy periods.

In order to avoid the necessity to use very long extension tubes, a plain section containing a number of small tubes bunched up in parallel, thus achieving the additional 16:1 ratio required to avoid deposition of very fine dust with an extension tube of moderate length. For practical purposes the small tubes are of hexagonal section as shown in figure .

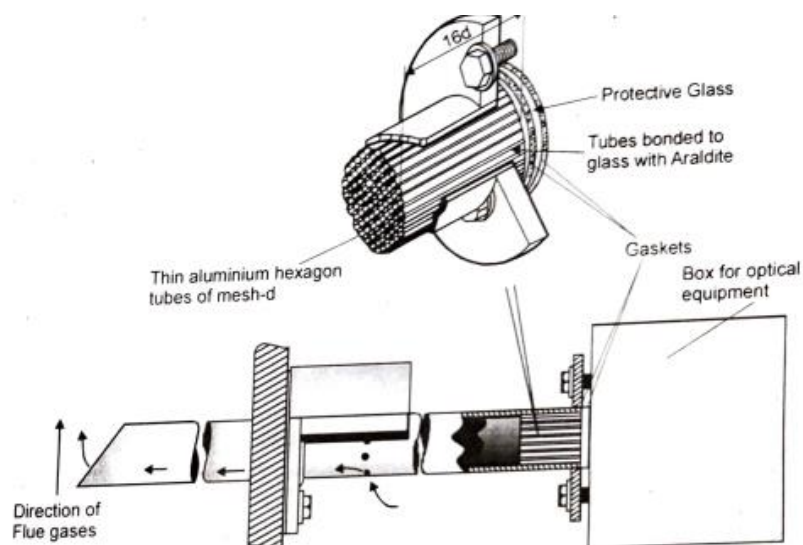

"Ever Clean" Window to Optical-Type Smoke Meter

Factors Affecting the Correct Operation of Smoke Meters

Inability to check regularly zero drift

Ageing of the lamp, photocell and other components and any slight buildup of dust on the lenses leads to a zero drift. It is only possible to check this drift under "clear duct" conditions which cannot therefore be regularly done on boiler plant in operation for lengthy periods. Proposals for carrying out this checking under load conditions, including more sophisticated meters measuring photo electric cell with reference circuits are under investigation.

Misalignment of Lamp and Photocell

When the smoke meter Circular Optical Wedge used to obtain output signal is installed on a duct, misalignment of the projector unit and the receiver unit may occur due to distortion of the duct under operating conditions, the light beam no longer shining directly on to the photocell.

The effect of this misalignment is worsened when "Everclean" windows Compensating Photo electric cell are fitted. Where alignment cannot be maintained under operating conditions it is necessary to mount the projector and receiver units on firm platform or other structures not attached to the duct.

DUST MEASUREMENT

The dust monitors installed in power stations during the past few years are:

- a) The C.E.R.L Flue Dust Monitor (Central Electricity Research Laboratory)
- b) The Konitest Flue Dust Monitor

The C.E.R.L Flue Dust Monitor

The C.E.R. L. dust monitor periodically collects a sample of grit and dust on a glass plate and measures the obscuration caused by this deposition using optical means. The glass plate is then blown clean by compressed air and the measuring cycle recommenced. As the sampling is non-isokinetic and by deposition only, the collection favors the larger particles, and it is claimed that this instrument particularly gives a warning of an emission likely to cause a nuisance. The principle of operation of the C.E.R.L monitor is that dust and grit enters an opening in the sampling head, which is inside the duct, and falls permanently on a glass plate.

A light source is beamed through the glass plate on to a photocell and the percentage obscuration caused by the deposition of the dust on this plate in a predetermined time is measured by the movement of a motor-driven circular optical wedge.

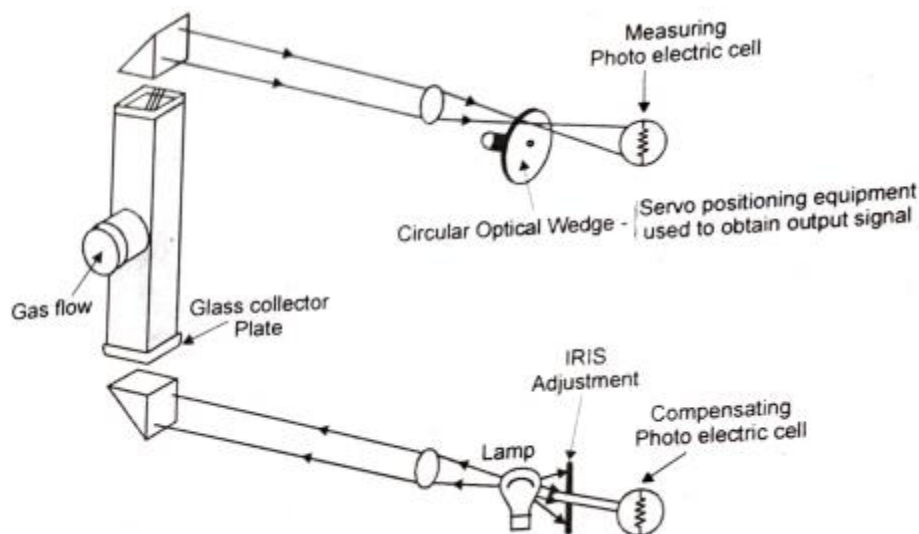

CERL dust monitor

On the completion of this measurement, a jet of compressed air blows the dust off the glass plate, the optical wedge adjusts itself to the zero condition now obtaining, and the cycle re-commences.

The recorder is provided with a circular chart on which, for each period of measurement, a line is drawn, radially, the length of which is a measure of the dust and grit concentration on the glass plate. The chart is scaled in percentage obscuration per minute.

An integrator is also provided. In principle it measures the ability of the dust to obscure a surface which is perpendicular to the gas flow, and hence its ability to obscure a vertical surface at ground level when due allowance has been made for dilution. Although primarily developed for the assessment of nuisance value in that any increase in the emission of large grit particles is immediately detected, the instrument normally indicates the rate of dust emission.

This indication can, by means of dust sampling tests, be calibrated as dust concentration. Such a calibration only holds good if the dust particle size is not significantly changed, and for this instrument will also require correction if the gas velocity differs from that during the calibration tests.

A reduction in precipitator efficiency is usually accompanied by increase in the coarseness of the emitted dust. The C.E.R.L monitor is likely therefore, to indicate such a reduction more readily than other types of monitors.

The Fordust Monitor

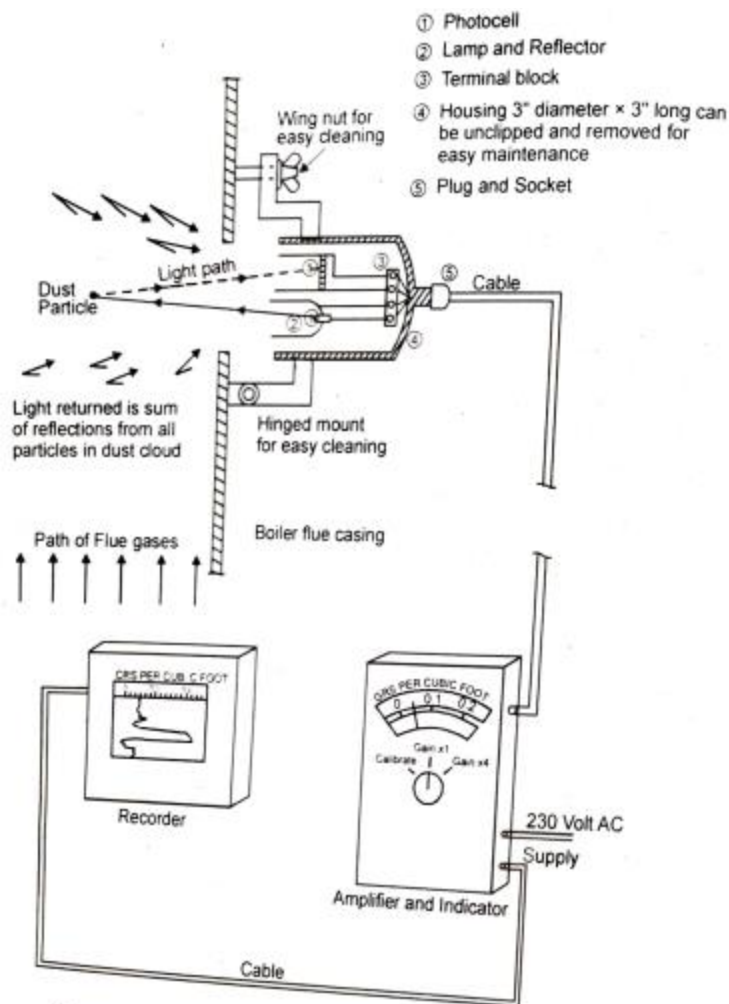

Fordust Reflected Light Dust Monitor

Instruments have existed for some time which measure the light reflected or scattered from dust instead of recording the light absorbed by dust. A recent example is the FORDUST instrument, as shown in figure in which a simple lamp and a photocell are mounted side by side.

The light from the lamp is beamed in to the duct through a suitable opening and some of this light will be reflected back on the photocell, the indication from which will vary with variation of the dust quantity in the gas.

A mathematical solution is somewhat complete, the indication being primarily on a function of the total dust area, although other considerations such as dust colour also have some effect.

As with other optical monitors the instrument indications can be Light path calibrated on a weight basis (grains/ft³) and used as a measure of dust emission provided that there is no significant change in the dust size grading.

The advantages of the FORDUST monitor are:

- a) No alignment problems
- b) Scans a larger volume of dust-laden gas than the obscuration type monitors
- c) Relatively free from corrosion due to absence of components within the duct.

ELECTRICAL MEASUREMENT IN POWER PLANT

Electrodynamometer type of instruments is used as a.c. voltmeters and ammeters both in the range of power frequencies and lower part of the audio frequency range. They are used as wattmeter, and with some as power factor meters and frequency meters. Recorder

Operating Principle

By taking up a permanent magnet moving coil instrument and considering how it would behave on a.c. It would have a torque in one direction during one half of the cycle and an equal effect in the opposite direction during the other half of the cycle.

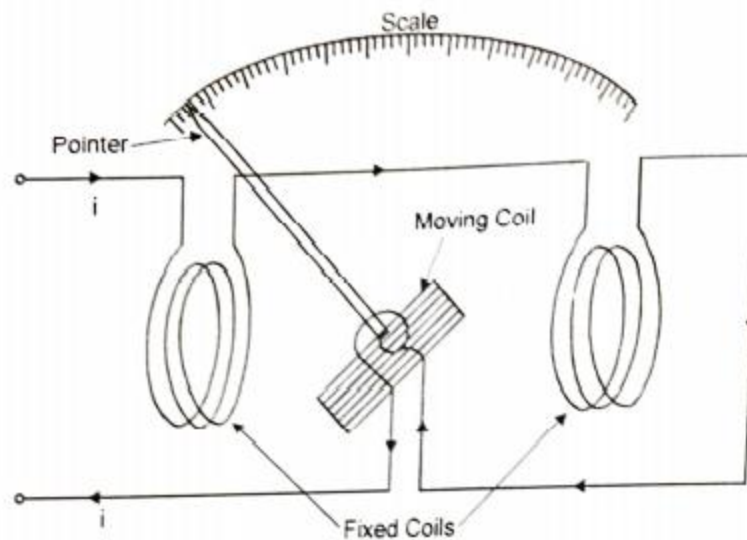

Electrodynamometer desired. type Instrument

If the frequency were very low, the pointer would swing back and forth around the zero point. However, for an ordinary meter, the inertia is so great on that power frequencies the pointer does not go very far in either direction but merely stays (vibrates slightly) around zero.

If, however, we were to reverse the direction of the flux each time the current through the movable coil reverses, a unidirectional torque would be produced for both positive and negative halves of the cycle.

In electro-dynamometer instruments the field can be made to reverse operating magnetic field of the instrument. Simultaneously with the current in the movable coil if the field (fixed) coil is connected in series with the movable coil.

Construction of Electro-dynamometer type Instrument

Fixed Coils:

The field is produced by a fixed coil. This coil is divided into two sections to give a more uniform field near the centre and to allow passage of the Shunt instrument shaft.

Fixed coils are usually wound with heavy wire in ammeters carrying the main current and wattmeter. The wire is standard where necessary eddy current to reduce losses in conductors.

Moving Coil:

A single element instrument has one moving coil. The moving coil is wound either as a self-sustaining coil or else on a non-metallic former. A metallic former cannot be used as eddy currents would be induced in it by the alternating field. Light but rigid construction is used for the moving coil. It should be noted that both fixed and moving coils are air cored.

Control:

The controlling force is provided by two control springs. These springs act as leads to the moving coil.

Moving System:

The moving coil is mounted on an aluminium spindle. The moving system also carries the counter weights and thus type pointer. Sometimes a suspension may be used in case a high sensitivity is Figure desired.

Damping:

Air friction damping is employed for these instruments and by a pair of aluminium vanes, attached to the spindle at the bottom. These vanes move in sector shaped chambers. Eddy current damping cannot be used in these instruments as the operating field is very weak and any introduction of a permanent magnet required for eddy current damping would distort the operating magnetic field of the instrument.

Electrodynamometer type ammeter

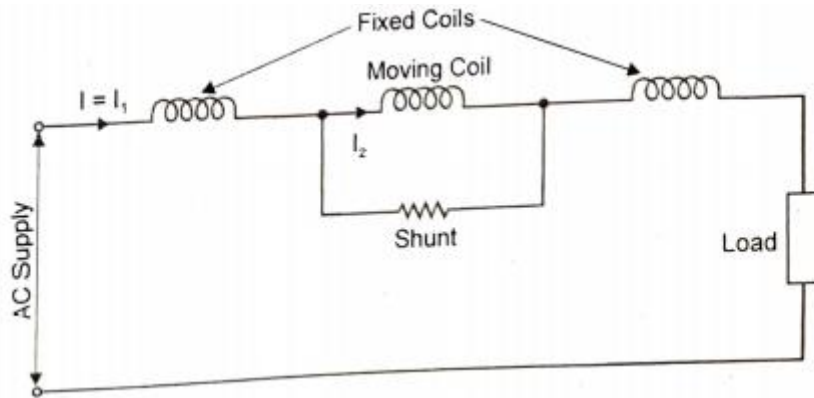

Figure. shows that the arrangement of coils of an electro-dynamometer ammeter. In this case the fixed and moving coils are connected in series and therefore, carries the same current

$$\text{i.e., } I_1 = I_2 = I \text{ and } \phi = 0$$

$$\therefore \text{ Deflecting Torque } T_d = I^2 \frac{dM}{d\theta}$$

$$\text{and deflection } \theta = \frac{I^2}{k} \frac{dM}{d\theta}$$

The current through the moving coil should not exceed 100mA and therefore, the arrangement of figure is suitable for ammeters having a Deflection, θ de range upto 100 mA.

In power plant, for ammeters of higher capacity, the arrangement shown in figure . is used. In this case the moving coil is shunted across by a low resistance to limit the current through moving coil to 100 mA.)

Thus there are two separate parallel branches for fixed and moving Moving CI coils. In order that the ammeter may indicate correctly at all frequencies, the time constant L/R of two branches should be equal as otherwise the currents will not be independent of frequency.

The electric connecting the dynamometer movement is used as a voltmeter by fixed and moving coils in series with a resistance. The high non-inductive arrangement is shown figure .

Electrodynamometer Voltmeter

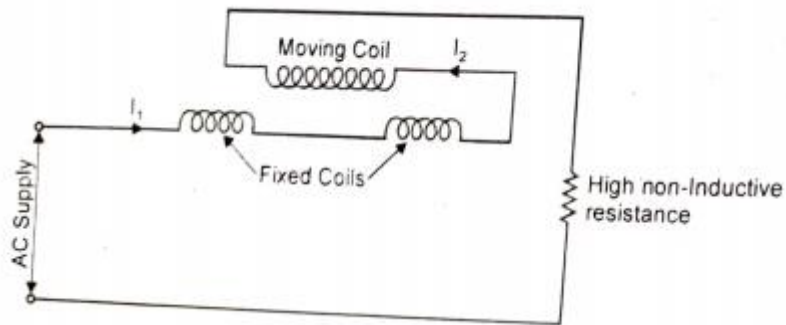

$$\text{Deflecting Torque, } T_d = I_1 I_2 \cos \theta \frac{dM}{d\theta}$$

$$I_1 = I_2 = \frac{V}{Z} \text{ and } \phi = 0$$

$$\therefore T_d = \left(\frac{V}{Z}\right) \cdot \left(\frac{V}{Z}\right) \cdot \frac{dM}{d\theta} = \left(\frac{V^2}{Z^2}\right) \cdot \frac{dM}{d\theta}$$

where V = Voltage across the instrument, Z = Impedance of the instrument circuit.

$$\text{Deflection, } \theta = \frac{V^2}{KZ^2} \cdot \frac{dM}{d\theta}$$

Electrodynamometer type voltmeter is the most accurate type of a.c. voltmeter

Electrodynamometer Wattmeter

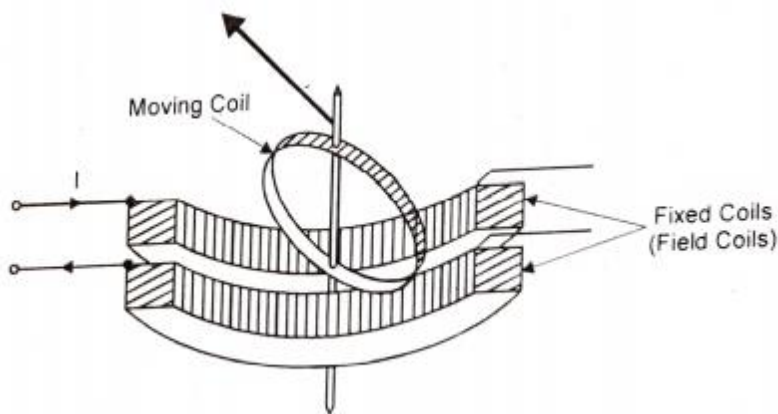

This instrument is similar in design and construction to electro-dynamometer type ammeters and voltmeters as shown in figure. The two coils are connected in different circuit for measurement of power.

The fixed coils (or) Field Coils" are connected in series with the load and so carry the current in the circuit, therefore form the "current coil" of the wattmeter as shown in figure.

The moving coil is connected across the voltage and therefore carries current proportional to the voltage. A high non-inductive resistance is connected in series with the moving coil to limit the current to a small value. Since the moving coil carries a current proportional to the voltage, it is called the "pressure coil" or "voltage coil".

Fixed Coils:

The fixed coils carry the current of the circuit. They are divided into two halves. The reason for using fixed coils as current coils is that they can be made massive and can be easily constructed to carry considerable current since they present no problem of leading the current in or out. The fixed coils are wound with heavy wire. In the case of precision wattmeter, the two halves of the fixed coil, which are connected in series for a basic measuring range can be connected in parallel to increase the wattmeter current range to twice its original value. Shunts are not used for extension of current range since they are subject to temperature errors.

Moving Coil:

The moving coil is mounted on a pivoted spindle and is entirely embraced by the fixed current coils. Spring control is used for the movement. The use of moving coil as pressure coil is a natural consequence of design requirements. Since the current of the moving coil is carried by the instrument springs, it is limited to values which can be carried safely by springs without appreciable heating. Both fixed and moving coils are air cored.

Control:

Spring control is used for the instrument

Damping:

Air friction damping is used. The moving system carries a light aluminum vane which moves in a sector shaped box. Electromagnetic or eddy current damping is not used as introduction of a permanent magnet will greatly distort the weak operating magnetic field.

$$\text{Deflection } \theta = I_p I \cos\theta \left(\frac{dM}{d\theta} \right) / k = \left(k_1 \frac{dM}{d\theta} \right) p$$

$$\text{Where } p = \text{power being measured} = VI \cos \phi \text{ and } k_1 = \frac{1}{R_p k}$$

Single Phase Electrodynamicometer Power Factor meter Power factor can be calculated from the relationship

$$\cos \phi = \frac{P}{VI}$$

The Power factor meter has a current circuit and a pressure circuit. Current circuit carries in the circuit whose power factor is to be measured. The pressure circuit is connected across the circuit whose power factor is to be measured and is usually split up into two parallel paths. One inductive and the other non-inductive. The deflection of the instrument depends upon the phase difference between the main current and currents in the two paths of the pressure circuit, i.e., upon the phase angle or power factor of the circuit. The deflection is indicated by a pointer. The moving system of power factor meter is perfectly balanced at equilibrium by two opposing forces and therefore there is no need for a controlling force.

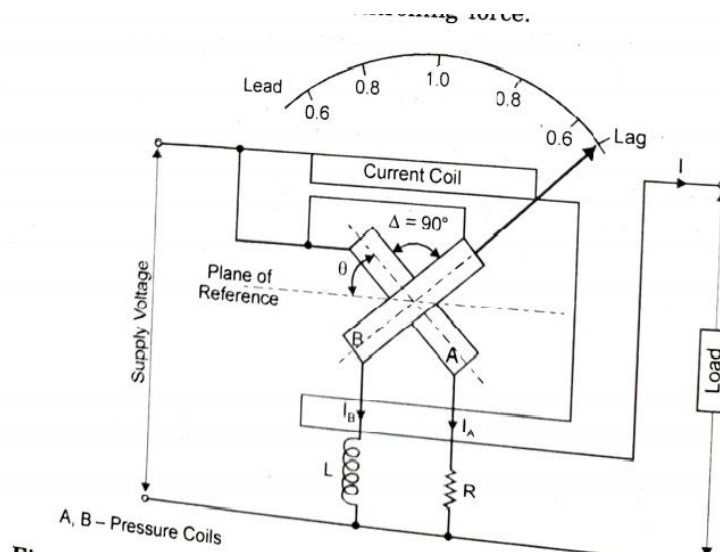

Electrodynamicometer Type Power Factor meter

Fixed coil is in series with an inductance, L , and capacitance, C , forming a resonant circuit of frequency, f , slightly below the lower end of the instrument scale. Fixed coil 2 is in series with inductance L , and capacitance C , forming a resonant circuit of frequency f , slightly higher than the upper end of the instrument scale. In the case of instruments for power frequency measurements, the circuits may be tuned to frequencies of 40 Hz and 60 Hz respectively with 50 Hz in the middle scale. The two parts of fixed coil are arranged as shown in the figure, their return circuits being through the movable coil. The torque on the movable element is proportional to the current through the moving coil. This current is the sum of the currents in the two parts of the fixed coil. For applied frequency, within the limits of the frequency range of the instrument, the circuit of fixed coil 1 operates above resonant frequency (as $X > X_c$ with current i_1 through it, lagging the applied voltage. The circuit of fixed coil 2 operates below the resonant frequency (as $X_c > X$ with current i_2 , leading the applied voltage. One fixed coil circuit is inductive and the other is capacitive and therefore the torques produced by the two currents i_1 and i_2 act in opposition on the moving coil. The resultant torque is a function of frequency of the applied voltage and therefore the meter scale can be calibrated in terms of frequency. The instrument scale spreads over an angle of about 90° . The controlling torque is provided by a small iron vane mounted on the moving system. This meter is used only for power frequency measurement and is used for power system for monitoring the frequency.

Measurement of Reactive Power

Reactive power, $Q = VI \sin \phi$ It is often convenient and even essential, that the reactive power be measured. For example, in load monitoring, such a measurement gives the operator or load dispatcher information concerning the nature of the load.

RADIATION DETECTORS

A lot of instrumentation is needed to measure the amount or radioactivity encountered in nuclear power plant and for tracking of radiated alpha, beta and gamma particles. The energy of these particles is absorbed by other molecules, producing chemical changes, ionization or other reactions that produce visual evidence of the presence of other particles. These process are used to detect, count and trace the movement of such particles.

Types of Radiations

Radioactive material emits nuclear radiations which mainly consist of four parts:

1) Alpha particles:

(The alpha particle is a helium nucleus consisting of two protons and one neutron. It has a mass of 6.6×10^{-27} kg and carries a positive charge of 3.2×10^{-19} C. The alpha particle is the heaviest and the slowest, travelling at speeds of from $1/10$ to $1/100$ of the velocity of light. Since it has the

greatest mass and slowest speed, it is least penetrating. It penetrates about 0.02 mm of aluminium foil.

2) Beta Particles:

The beta particles are an electron with a mass of 9.11×10^{-31} kg and a charge of 1.6×10^{-19} C. Since beta particle is much lighter than alpha particle and has a speed approximately equal to that of light, it can penetrate much farther than alpha particles-about 100 times the penetration of alpha particle.

3) Gamma Particles:

Gamma particles or gamma rays are an electromagnetic radiation with a wavelength of approximately 0.03 to 3 angstrom. Gamma particles travel at the speed of light and because of their shorter wavelengths, have very great penetrating power. Gamma rays can penetrate about 20 cm through a mass of lead.

4) Neutrons:

The mass of the neutron is intermediate between that of alpha and beta particles, having the same mass as a proton. The speeds of neutrons may be high or low depending upon the source from which they are emitted. Because neutron has no charge it is very difficult to detect. However, its penetrating power is small.

The above mentioned properties of these particles must be considered in the methods and processes for their detection and measurement.

Types of Radiation Detections

- i) Geiger Muller Tube
- ii) Ionisation Chamber
- iii) Scintillation Counter

Geiger Muller Tube

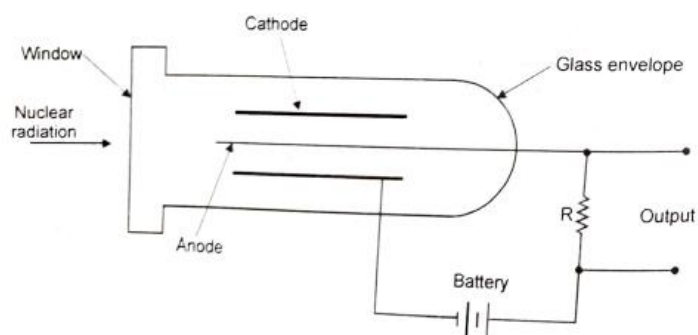

The Geiger Muller tube or simply Geiger tube is frequently used for detection and measurement of alpha, beta and gamma rays. This tube is a diode, consisting of a cathode which is a long metal cylinder and an anode which is a fine wire running through the centre of the cylinder.

Both of them are mounted in a thin walled, air tight, glass envelope sealed by an extremely thin window through which radiations may pass at one end as shown in figure. The air is evacuated from the envelope and a small amount of an inert gas, such as Argon, is added.

The voltage of the battery is kept below the ionization potential of the gas. Now if radiation penetrates through the window and enters the envelope it would ionize some of the gas atoms.

The resulting negative ions move towards the anode and positive ions towards the cathode. In their passage, the ions collide with some of the gas atoms, causing them to be ionized in turn. This process continues till whole of the gas atoms are ionized. In fact complete ionization takes place in no time.

A pulse of current thus flows through the tube. This current flows through resistance, R which is connected in the anode circuit. The resulting voltage drop across R is the output voltage.

Once ionization is established, it is expected to continue indefinitely. However, since resistor R , which has a high resistance, is connected in series with the anode and the battery, when the gas ionizes a heavy current flows through resistance causing a large voltage drop. This voltage drop is sufficient to reduce the anode voltage below the ionization potential and therefore ionization occurs.

As long as the gas is not ionized, no current flows through the resistance R and hence there is no output. Thus when the gas deionizes, the current ceases to flow through resistance R and so there is no output.

Now irradiation again enters the tube, the ionization starts and a current again flows through resistance R giving an output voltage. This way a series of alpha or beta particles or bursts of gamma rays, cause a series of current pulses to pass through the anode circuit of the tube and hence through resistance, R . The output pulses from resistance, R may be amplified and registered by a counting device.

By counting the number of pulses, we can know the number of particles entering the Geiger Muller tube in a particular interval of time.

The number counted gives the intensity of radiation. The pulses may be stored in some cases and the total count may be calibrated directly in terms of radio-activity. The counting rate of this tube is greater than 10^6 counts per second.

Ionisation Chamber

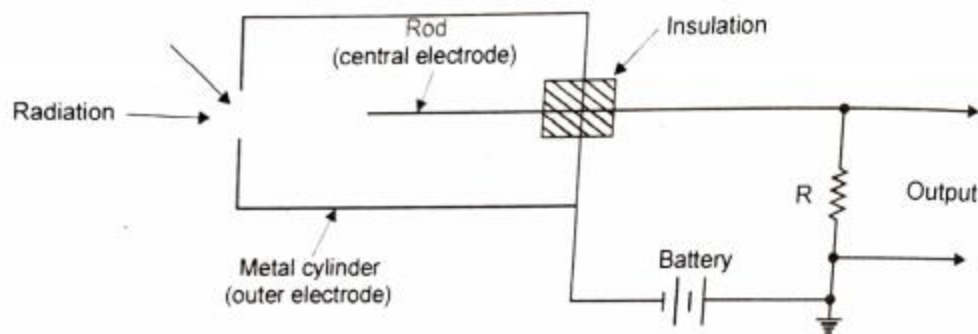

The ionization Chamber is a metal cylinder (the outer electrode) sealed at one end by a window. The other end of the cylinder is closed, and a metal rod (the centre electrode) protrudes outside the cylinder on this end, as shown in figure.

The central electrode is grounded through resistance R. Resistor R has a very high resistance. A large positive potential is applied the outer electrode. The chamber contains a gas which may be air, carbon diode, nitrogen, argon or methane.

The action of this ionization chamber is similar to that of Geiger Muller tube. Let us consider that the chamber is filled with air. When a nuclear scintillation counter radiation enters the chamber through the window, some of the atoms of the air are ionized, the resulting ions travel towards their respective electrodes i.e., positive ions towards the central electrode and the negative ions towards Every time if a radiation strikes the scintillation crystals a tiny flash of light is produced. The flash of light is amplified by a photomultiplier the outer electrode.

In the process of rushing electrodes, these ions collide with other atoms of air causing ionization of these atoms. The action is instantaneous.

As the positive ions collect on the central electrode (which is at ground potential), the d.c. potential of this electrode is increased. This increased potential, which is the output signal of the chamber, may then be amplified per second and measured. Since the increase in this potential is a function of the number of radiation particles that have entered the chamber, the intensity of the nuclear may be determined. The main use of this chamber, is to detect and Radiation measure alpha particles.

Scintillation Counters

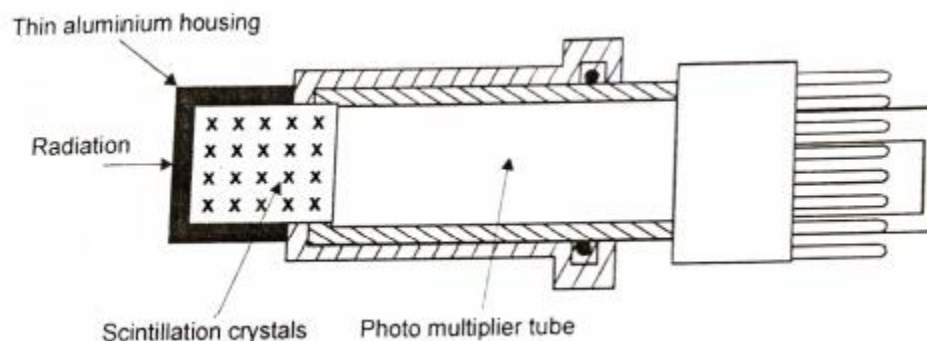

Certain crystals such as zinc sulphide, sodium iodide, anthracene and naphthalene etc., produce a brief flash of light each time they are struck by an alpha, beta or gamma particles/The production of a flash of light by striking the crystals mentioned above, with alpha or beta or gamma rays is called scintillation. This principle is employed in a nuclear radiation sensor called scintillation counter as shown in figure.

Every time if a radiation strikes the scintillation crystals a tiny flash of light is produced. The flash of light is amplified by a photomultiplier incorporated in the scintillation counter.

Thus each particle produces a pulse of anode current at the output of the photomultiplier. The output of the photomultiplier is applied to a high speed electronic counter which counts every tiny flash generated by the scintillation crystals.

Thus by counting the number of pulses in a given period of radiation may be detected. Its counting rate is very fast by counting the number of pulses in a given period of time, comparing to Geiger Muller.

PRESSURE TRANSDUCERS

1. Bourdon Tubes
2. Bellows
3. Diaphragms
4. Capsules

Bourdon Tubes

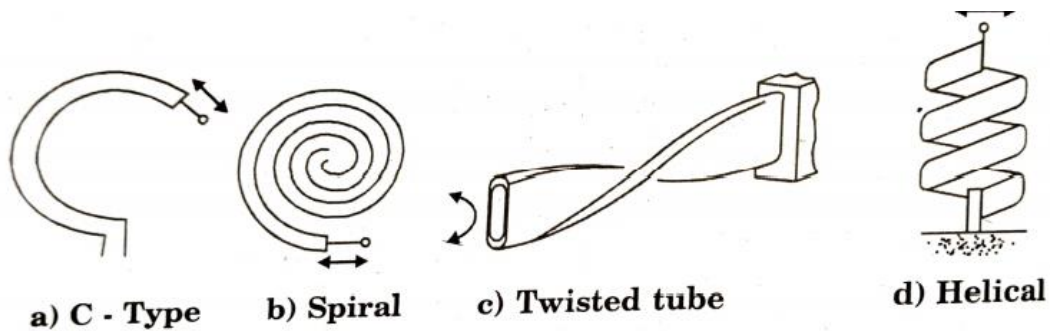

The Bourdon tubes are designed in various forms namely C-type, spiral, twisted tube and helical as shown in figure. The Bourdon tubes are made out of an elliptically flattened tube bent in such a way that so as to produce the above mentioned shapes. One end of the tube is sealed or closed. The other end is open for the fluid to enter.

When the fluid whose pressure is to be measured enters the tube, the tube tends to straighten out on account of the pressure applied. This causes a movement of the free end (closed end) and the displacement of this end is amplified through mechanical linkages

The amplified displacement of the free end may be used to move a pointer on a scale calibrated in terms of pressure or may be applied to an electrical displacement transducer whose output may be calibrated in terms of the pressure applied.

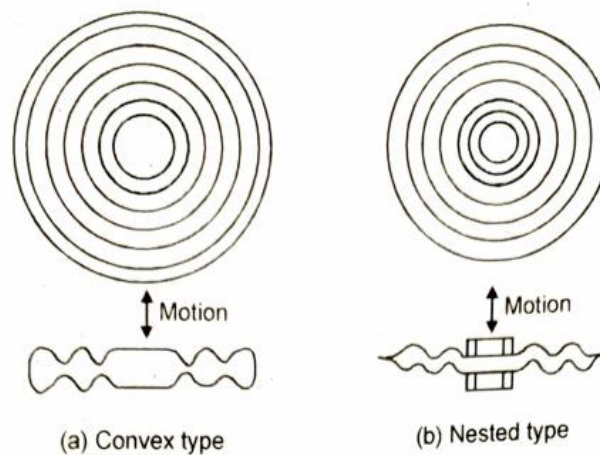

Types of Capsules

STRAIN GAUGES

If a metal conductor is stretched or compressed, its resistance changes on account of the fact that both length and diameter of conductor change. Also there is a change in the value of resistivity of the conductor when it is strained and this property is called piezo resistive effect. Therefore,

resistance strain gauges are also known as piezo resistive gauges. The strain gauges used for measurement of strain and associated stress in experimental stress analysis. Secondly, many other detectors and transducers, notably the load cells, torque meter, diaphragm type pressure gauges, temperature sensors, accelerometers and flow meters, employ strain gauges as secondary transducers.

Type of Strain Gauges

1. Unbonded metal strain gauges
2. Bonded metal wire strain gauges
3. Bonded metal foil strain gauges
4. Vacuum deposited thin metal film strain gauges
5. Sputter deposited thin metal film strain gauges
6. Bonded semiconductor strain gauges
7. Diffused metal strain gauges

UNIT – III

Analysers in Power Plants

FLUE GAS ANALYSIS

There is a general perception that flue gas analysis instrumentation is more complex, more costly and less reliable than other types of measuring instruments normally used in boiler control systems. On the other hand, the analysis of flue gas provides a measurement that is more precise than fuel/air ratio measurements.

Analysis

1. % Oxygen (%O₂) - Excess combustion air is a function of % Oxygen.
2. % Opacity -A measurement of smoke or particulate matter. Due to environmental standards, this measurement may be needed for use in limiting the control action based upon other analyses. When total combustion air is a function of % carbon dioxide.
3. % Carbon dioxide (CO₂) greater than 100% of that theoretically required, excess combustion air is a function of % carbon dioxide.
- 4/ Carbon monoxide (CO) or total combustible in the ppm range - This measurement is that of unburned gases., Measurement in the ppm range is necessary if desired control precision is to be obtained.

Uses

- % Oxygen as an individual control index.
- ppm CO or total combustible as an individual control index.
- % Oxygen in combination with ppm CO or total combustible.
- % Carbon dioxide in combination with ppm CO testing.
- %Oxygen in combination with % opacity

METHODS OF FLUE GAS ANALYSIS

- i) The "In Situ" point sample method.
- ii) Extractive or "Ex Situ" method.
- iii) Light or Infrared Beam across the stack.

In Situ Flue Gas Analysis

Percent Oxygen and ppm CO can be measured in this method.

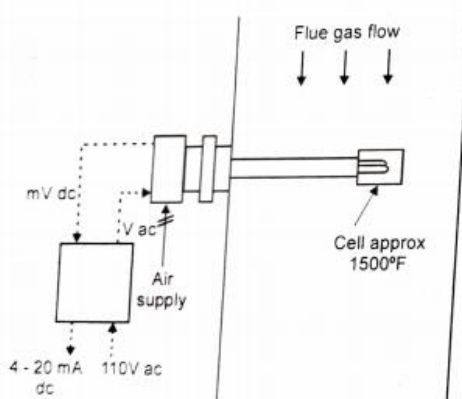

In Situ Flue gas analysis

This method uses an analyzer's probe, which is inserted into the duct at the point of analysis. Analyzes cell on the end of the analyzer's hot flue gas flowing past it. With no sampling system time lag, typical response times of these analyzers is 50 to 10 second Fig. 3.1 shows the arrangement for this method.

The analysis will be that existing at the point of cell location in the duct. Due to stratification of the flow in large ducts, electric utility boilers generally use several probes at different locations in the duct cross section. The best location of these probes can be determined by traverse testing.

The location of this type of probe along the flue gas stream is very flexible needs only on a open area on one side of the boiler duct system for probe insertion. Because of the air seal leakage of regenerative air preheater, the analyzer probes should be installed in the flue gas stream ahead of such air preheater.

If % oxygen is being measured, the measuring cell is Zirconium oxide. The principle is that of a fuel cell. The cell reacts to the ratio of the partial pressure of oxygen in the flue gas to the partial pressure of oxygen in reference air that is also admitted to the cell. Because of the cell temperature, any residual combustible gas is burned in the cell and absorbs some of the oxygen in the flue gas. The result is therefore, a measurement of % net oxygen.

The output of the cell is a mill volt signal that is an analog of the logarithm of the partial pressure ratio of the % oxygen in the flue gas to that of the reference air. In order that results will be accurate and repeatable, the cell temperature is closely controlled./The typical controlled temperature set point for such cells is in the 1300 to 1600°F range. The upper temperature limit for this method is that of the cell

The cell output (approximately 0 to 100m V) is further processed by inversion, linearization and amplification to produce a linear signal of % Oxygen Vs milli PS (mA). In this form the signal can easily be used by any form of standard control instrumentation.

(If ppm CO is being measured, the analysis cell operates on the infrared absorption principle. In this principle, carbon monoxide absorbs a part of infrared energy from an included infrared source. The amount absorbed is within the frequency range specific to carbon monoxide. Measuring the absorption of infrared energy within that range provides a measurement of carbon monoxide. The resulting electrical signal in some of the ppm CO analyzers is compensated for % moisture, temperature and excess air and is processed and amplified to that of a standard instrumentation signal.

Extractive of "Ex Situ" Method

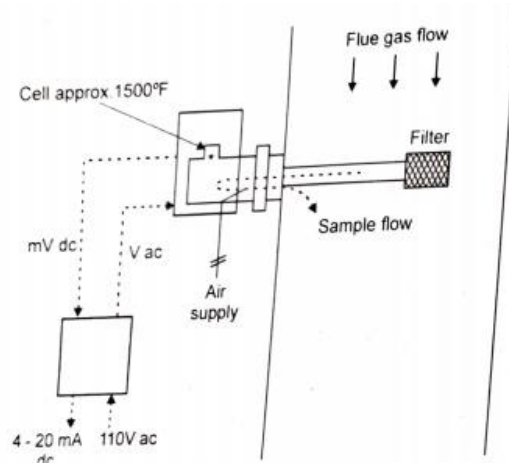

Extractive or Ex Situ Flue Gas Analysis

The extractive or ex situ method is as shown in fig. In this method a small sample of the flue gas is drawn from the duct to the heated cell housing mounted on the duct wall. Because the sample is admitted back in to the duct after analysis and never cooled below the dew point, sampling maintenance is not normally a problem. As with the "In Situ" method the analysis is on the "wet" basis.

For an air aspirated sample, the response time of this method is typically in the range of 10 to 15 seconds.) For natural or thermal aspiration, the response time is in the range of 25 to 40 seconds. Both time periods consist only of the sample transport dead time duration from the tip of the sample probe to the cell. Typically, another 15 seconds of dead time should be added for the sample transport time from the burner to the sample point. This applies to all flue gas analyzers.

The measurement is the analysis of the flue gas existing of the tip or the sample probe. As with the In situ method, for installations in the large ducts of electric utility size boilers, averages of

several individual duct measurements are needed. Special averaging sample probes can be used or multiple analyzers can be used and their output signals averaged.

As with the In situ analyzers, the location along the flue gas stream is flexible since installation is made from one side of the boiler or flue gas ducts. Also as with the In situ analyzers, the installation should be ahead of sources of "tramp" air, such as the leakage of the seals of regenerative air pre heaters.

This method is applicable to the measurement of % oxygen and ppm Vs ac or % total combustible.

If % oxygen is being measured, the measurement principle is the same as that of the In situ analyzers. In this case, the temperature controlled zirconium oxide cell (approximately 1500° F) is located in the cell housing, mounted on the duct instead of in the flue gas stream. The 4-20 mA 110V ac dc measurement signal and signal processing functions are also the same for the two methods.

Since the temperature - controlled cell is located outside the flue gas stream, cell temperature does not limit the application of this type of analyzer. In this case, the limit is based on the material of the sample probe. By using sample probes of ceramic material, flue gases can be analyzed with this system up to more than 3000°F.

If ppm total combustible is being measured, a catalytic combustion principle is used. In this case, any remaining combustible gas that is present in the flue gas is "burned" in the measurement cell to produce a signal that is then amplified to that of standard measuring instrumentation. The transport of the flue gas sample to the cell is identical to that of the % oxygen measurement. The cell can also be housed in the same assembly with the cell for measuring % oxygen, and the same the gas sample can be used. In this case, two output signals are obtained: % Oxygen and ppm or % total combustible.

Light or Infrared Beam across the Stack

The third general method is the use of a beam of light or infrared energy across a flue gas duct or stack. This arrangement is shown in figure. This method is applicable to the measurement of ppm Co %CO, and % Opacity. If ppm CO is being measured, the beam is infrared energy. The same principle of selective infrared absorption as used in the "In Situ" ppm CO is also used in this type of analyzers. Analyzing the infrared absorption in an additional frequency range the is sometimes used to measure %o Carbon dioxide (CO₂). As with the In Situ measurement of ppm CO the normal application limitation of 600 to 700° F flue gas temperature applies.

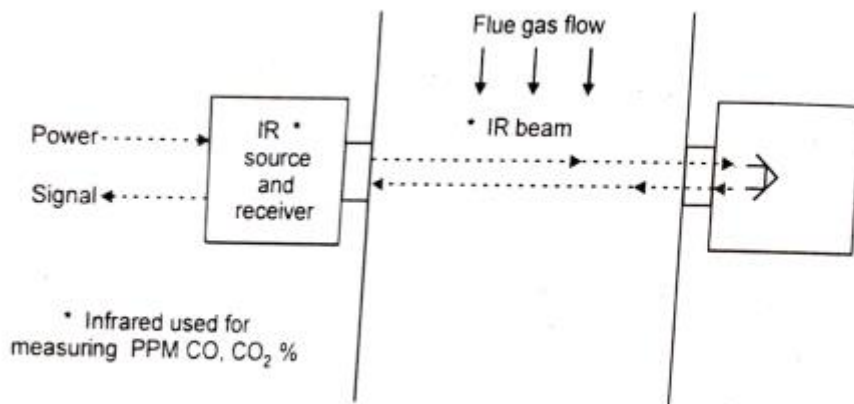

(a) Double pass system

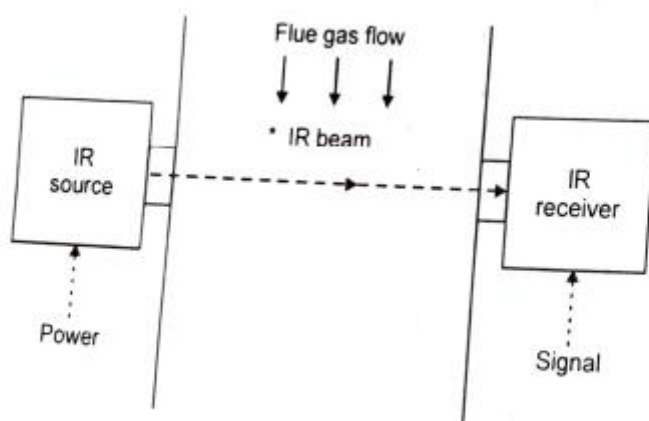

(b) Single pass system

"Across the Stack" Flue Gas measurement

The IR beam is transmitted through the flue gas from one side to the other. Both single-pass systems (measurement on the opposite side of the duct or stack from the source) and double-pass (in which the beam is reflected back to the side of the source) systems are used. Carbon monoxide in the PPM range and opacity are generally measured in this manner.

If ppm CO is measured, the formula that is used to calculate the signal is known as Beer's Law". One factor used directly is the length of the infrared path. The result is that a double-pass device has a greater signal and greater sensitivity.

If % Opacity is to be measured, the essential principle is that a beam of light is passed across the duct, and the measurement of light intensity that is received on the opposite side is a measure of % Opacity.

For the applications described above, in general, locations must be and Signal found that are free of obstruction on both sides of the duct or flue gas stack. This often dictates that the analyzer be located in the flue gas stream after the air infiltration or leakage at the air pre heater. This also tends to make the installation and location of this type of analysis less flexible and more costly than that of the single-side installations.

FLUE GAS OXYGEN ANALYSERS

Paramagnetic Oxygen Meter

Measurements of Oxygen and carbon dioxide content of flue gas are used as a guide to combustion.

The change in oxygen percentage is proportional to the change in excess air, so that this measurement is the most appropriate one to apply to the combustion control process. An additional advantage in using oxygen content for control purposes is that any change in its value is a larger fraction of scale reading than the corresponding change in carbon dioxide percentage. For gases which contain a varying amount of sulphur dioxide there would be changes in the value of carbon dioxide since the nitrogen content has to remain the same.

Oxygen content is measured in a paramagnetic type of instrument shown in fig. 3.4 and such a device has a quick response which is in favor of using oxygen for control purposes.

Operation

Most gases are diamagnetic, i.e., gas will seek the weakest part of Magnetic field, but oxygen is one of the few exceptions. The oxygen analyses employs the paramagnetic property of Oxygen and dependence of this property on temperature. The gas to be analyzed is introduced into an analysis cell and passes through the annulus indicated by the arrows.

The analysis cell contains a horizontal bypass tube which supports on its outer surface two adjacent identical platinum windings. These are connected to adjacent arms of a wheatstone bridge and are heated when a voltage is applied across the bridge. To recorder One of these windings is traversed diametrically by an intense magnetic field provided by a large permanent magnet, and when the gas sample passes the end of the tube nearest the intense magnetic field it is drawn in to the tube and heated by the windings the magnetic susceptibility of the oxygen content of the gas sample is thus reduced and fresh cool gas entering the tube forces the warm gas out of the other end AC supply of the tube in to the annulus.

This continuous gas flow, termed "Magnetic wind", causes differential cooling of the two winding sand as the resistance of the platinum windings changes the temperature, the bridge becomes unbalanced.

The resulting emf is measured by a potentiometer, and as it is proportional to the oxygen content, the reading is shown as a percentage oxygen content of the sample admitted to the analyzers.

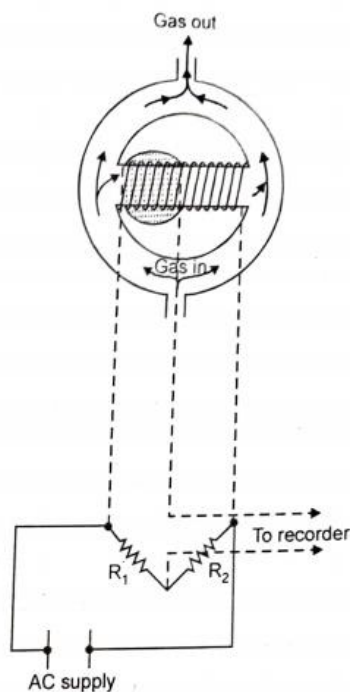

Paramagnetic oxygen analyzer

MEASUREMENT OF IMPURITIES IN FEEDWATER AND STEAM

In power plants, the water should be of purest form and the contaminants should be kept to minimum to avoid serious troubles. If the concentration of impurities exceeds certain limits in high pressure and temperature steam plants, these may cause scale formation, corrosion and cracking of metallic parts of the plant.

The Major impurities that are generally found in water are:

- i) Sodium, calcium chlorides and sulphates which largely result from leakages in the condenser where circulating water enters the condensate. Sometimes magnesium compounds also occur.
- ii) Copper and iron pick-up from metals of the plant through when feed water and steam have passed.
- iii) Carbon-dioxide in evaporator distillates.
- iv) Dissolved oxygen from contact with air in condensers and sometimes in the feed-heater drains because of bad venting or occlusions or leakages at low loads.

v) Ammonia from condenser leakage or from distillates derived from raw water.

vi) Silica from inherent dust residues and from the walls of vessels and pipes.

The Various instruments employed to detect these impurities are: - Insulating tube

i) Electrical conductivity meter Insulating tube

ii) Dissolved oxygen meter.

iii) Hydrogen Ion concentration (pH) meter.

Electrical conductivity meter

Wire ring (positive) Gun metal casing connected to. It is used to check the existence of electrolytes, such as NaCl in feed water.

The correct unit of measurement is the micro mho per centimeter at 20°C. (It has been recommended the conductivity of water should not exceed 0.3 micro mho/cm at 20°C,

The most commonly used instrument for determining the purity of water based on the electrical conductivity principle is the "Ionic Water purity meter".) The electrical conductivity of an aqueous solution is dependent on the inorganic impurity and the apparatus measures this in terms of resistance of a standard water column or tube through which the sample is passed as shown in Fig. 3.5. The reference is a resistance of one meg ohm between the opposite faces of centimeter cube of the water or solution. The conductivity is measured of two water columns in parallel, i.e., between the platinum rings and the gun metal collars. The conductivity is the reciprocal of this and is equal to one micro mho per cm. The temperature should be 20°C, if it is not, an automatic correction will be made by the instrument. Degasifying chambers are generally provided to avoid errors which may be caused by carbon-dioxide occlusions.

The water connections are made via insulating tubes because the inner casing is alive, i.e., at negative potential direct current. The electrical connecting diagram for this instrument is shown in Fig. 3.6. (Another type of conductivity meter generally used has temperature Compensation and operates on a "Null Balance" principle.

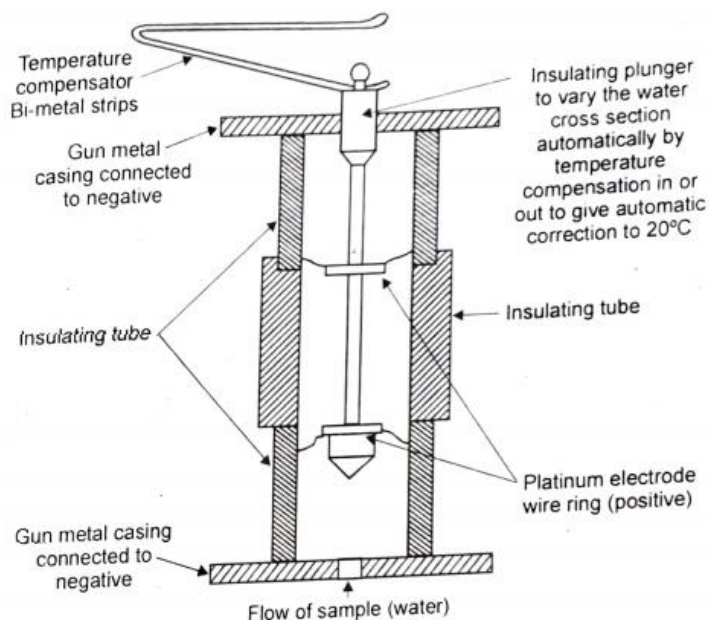

Water purity meter

Steam Purity Meter

On large modern steam generators working at high pressure, it is necessary to monitor the purity of the steam supplied to the turbines. The instrument used for this purpose also works on the same principle as described for water testing. In this instrument means are provided for condensing the steam and for degasifying it before conductive measurement. (Special platinum electrodes are used in place of gun casing. Voltage alternating current is used instead of direct current.

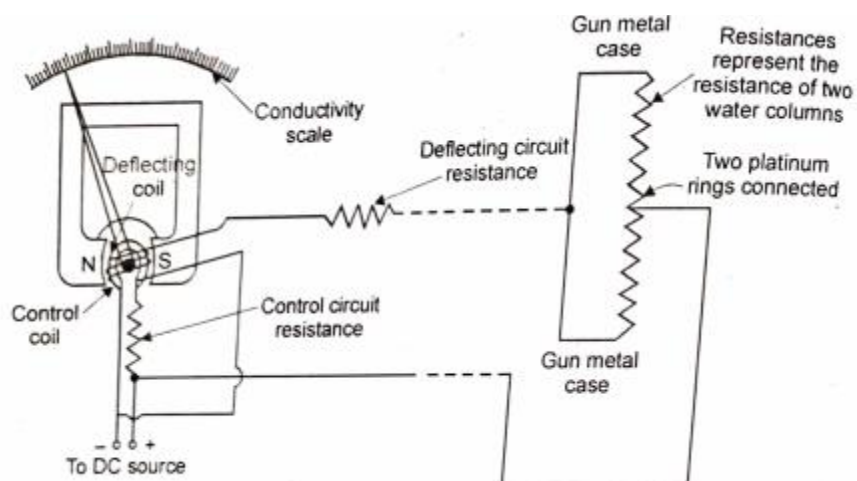

Circuit for water purity meter

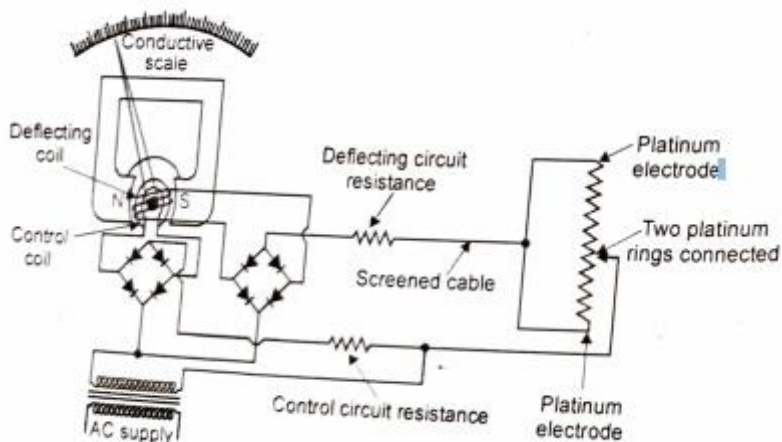

Circuit for steam purity meter

Flame photometer

For the measurement of steam purity. The purity of the steam supplied to turbines is usually monitored, the specified limit being equivalent to a conductivity of not more than 0.3 mho/cm at 20°C. This value is applicable to the measurement taken after a action exchange column, otherwise the conductivity value would be a higher figure (due to dissolved gases) and would only be an approximate guide to the effectiveness of feed water treatment and boiler priming.

The steam is sampled by passing a small quantity of it through the cooling coils of a stainless steel condenser. The condensed steam is passed through a caption exchange at a sample flow rate of about a quarter of that for feed water sampling due to the longer time needed for the sampling process. The water thus treated is measured for conductivity in a similar way to that described for water testing. High frequency a.c. current is usual for the measurement, as it can be conveniently obtained and is free from polarizing error should conductivity be too high.

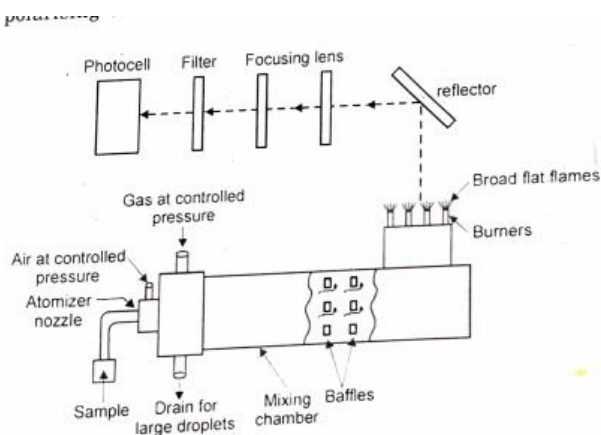

Flame photometer

Because of the high level of steam purity required in the systems of steam generation employed for large modern boilers, purity determination by conductivity metre is not sufficiently sensitive and in such cases sodium flame photometers are often used because the impurities are mainly sodium salts, which are added as conditioning. Chemicals are present due to cooling water leakage in condensers or other casual sources of contamination.

Operation

A simplified arrangement of a laboratory flame photometer is as shown in fig. 3.8. Illustrates the principle of the apparatus which consists of three mass parts, namely atomiser, combustion chamber and optical system.

Air enters through the tube at a controllable pressure in to the atomizer nozzle, while gas enters another tube as shown at a controlled W pressure.

The airflow around R2 Feed water the atomizer draws the sample up the capillary tube in to the atomizer which injects in to the mixing chamber, the larger drops leaving through drain. The baffles produce an even mixture of gas, air and sample which passes to the burner where it is ignited to burn with a broad flat flame within a well ventilated chimney.

Light from the flame is collected by the reflector and focused by lens through the filter on the photocell. The crystal wavelength is isolated by the filter and the intensity of the emitted light as detected by the photocell represents the sodium content which can be calibrated using Waste solutions of known sodium concentration.

Dissolved oxygen analyzers

Katharometer Dissolved Oxygen Analyses

Diagrammatic layout of the Katharometer through which sample water flows from the constant head tower (W) in to vessel (B) which maintains the electrical elements R, and R, at an even temperature. The water at a temperature of 20° C passes through an orifice (D) which regulates the flow to 400 cc/min, then down the scrubbing tower (C) and out through the water seal (E).

The space in the constant head tower and around the sensitive element R, is filled with hydrogen generated by the electrolytic cell (J). surplus gas being ejected through bubbler (N). The sensitive forms one arm of a wheatstone bridge, the opposing arm of the bridge being element R, which is sealed in an envelope filled with hydrogen and also placed in vessel (B), thus compensation for any change in temperature of the sample. Any oxygen in the water will be liberated in the scrubbing (C), forming a hydrogen-oxygen mixture which will affect the thermal conductivity of the gas and alter the temperature and consequently the resistance of the element R,. This unbalances the Wheatstone bridge circuit and causes a reading on the recording instrument (R) which is generally provided with a scale range up to 0.25 ppm.

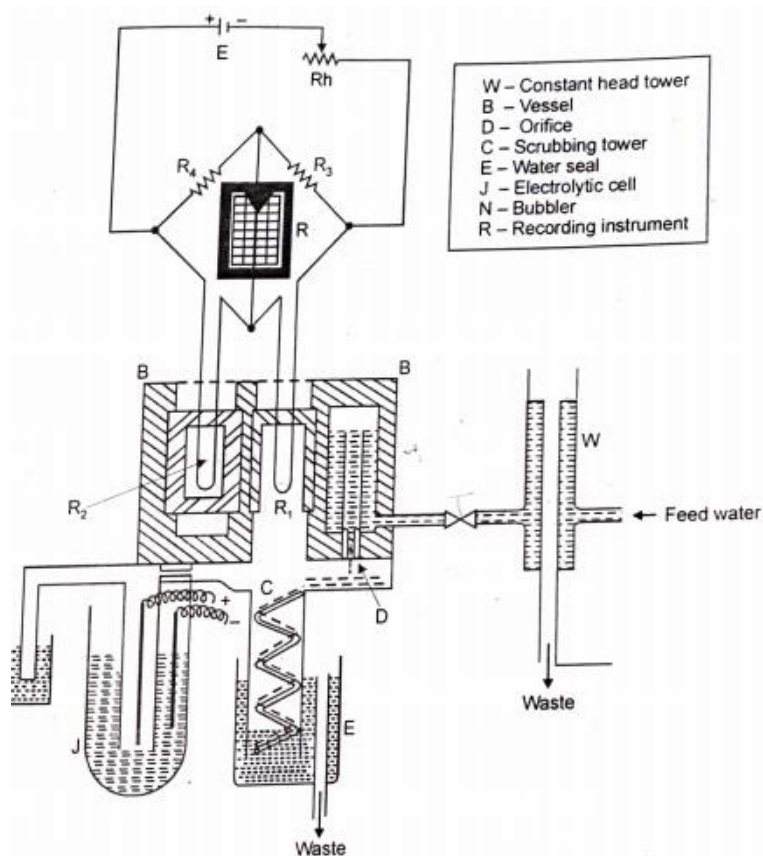

Katharometer dissolved oxygen analyses

Electrochemical Dissolved Oxygen meter

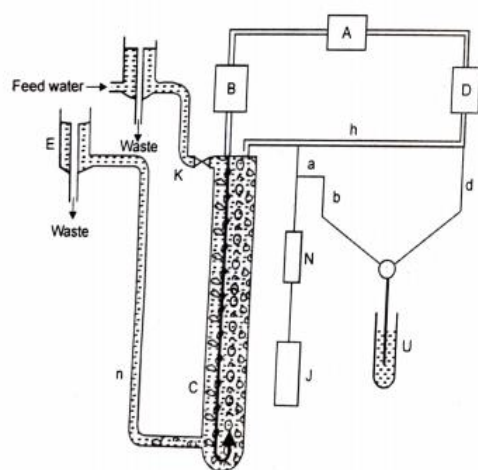

Electrochemical dissolved oxygen meter

The standard for dissolved oxygen in feed water for modern high pressure boilers is that it must not exceed 0.007 PPM (be weight) and electrochemical equipment was developed to measure this accurately with a scale range 0.001 PPM, a sensitivity of 0.0001 PPM and the response time less than 10 sec. In this meter, the oxygen gas is scrubbed, as shown in Fig. 3.10. The equipment has constant head at input and output and the flow can be regulated by a valve device K. Hydrogen is generated electrolytically in J, any traces of oxygen being removed in N', so that pure hydrogen flows in a closed loop through measuring cell D', pump 'A', and calibrating cell °B The measuring circuit is maintained under pressure of hydrogen gas through pipes 'a' and h' any surplus escaping from a bubbler U through pipe b. Piped' is normally closed.

The purpose of pipe 'd' is for zeroing the equipment. This is done by stopping the flow of water through the scrubber 'C' and flushing out the gas circuit with pure hydrogen with pipe b' closed and pipe 'd' open. All the electrolytically produced hydrogen passes through the measuring system, and if it is oxygen free the cell must produce a zero reading. If now pipe 'd' is closed and 'b' opened to prevent further hydrogen entering (with no water flow) any upward drift in the reading will indicate a leak of air in to the measuring system, which must be traced and stopped. With this gas transfer method, the oxygen in solution is removed until the concentration of oxygen to hydrogen (gas phase) is in equilibrium with that dissolved in water (liquid phase). The oxygen in the two phases is then related by the law of solubility of gases, and calibration of the current from the electrochemical cell can be made for known oxygen concentrations.

CHROMATOGRAPHY

The Chromatograph type of analyser can be used to measure the amount of individual gases in a mixture, Chromatograph analysis in a repetitive sampling procedure. The analyser automatically takes a sample of gas and injects it as a constant volume in to a portion of the analyser known as the chromatographic column, the gas sample being passed through the column by a carrier gas.

The nature of the sampled gas components can be readily identified by the time taken to pass through the column, as it is a feature of gas chromatography that a given substance will always emerge from the column after a known interval of time for a given set of conditions. At the end of the column director-usually a thermal conductivity measuring device signals the amount of each component in the sample.

Operation

The helium carrier gas takes the sample of flue gas through two chromatograph columns as in fig.3.13 (a). column is 30 in. long and is packed with 30% hexamethyl phosphoramidate (HMPA), while column2 is 6ft 60in. long filled with activated molecular sieve 13%. Before the sample is injected in to the apparatus the helium passes two thermistors in the thermal conductivity cell, flow through column, then the third thermistor,column2, and lastly past the fourth thermistor.

The cooling effect in all four arms of the bridge is, therefore, equal, the electrical reading zero and a datum line commences on the recorder chart.

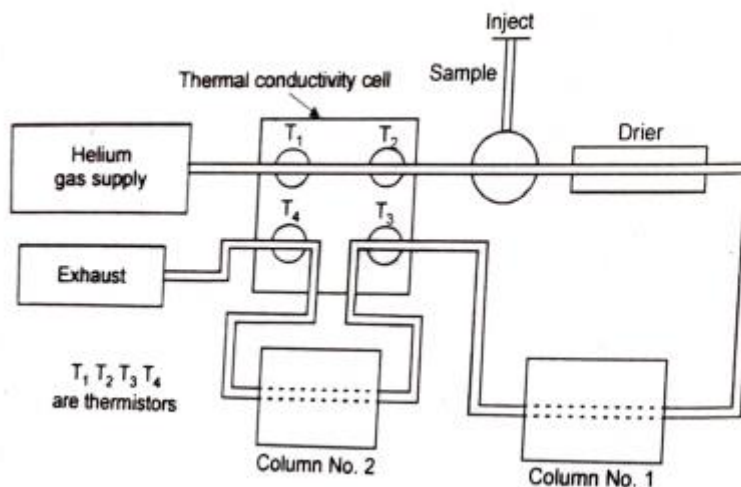

Chromatograph apparatus

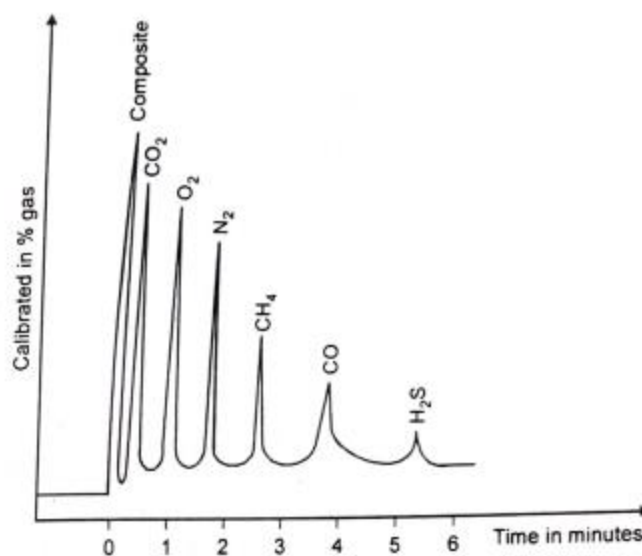

Chromatogram

Chromatographic analyser

As soon as the sample of gas composed of say. CO, CO, HS, CH, N, and O, is injected, the CO, and H₂S are held back by the (HMPA) column. The other gases proceed to the first detector (third thermistor, T_3) and unbalance the electrical bridge, thus causing a deflection of the recorder pen to mark these combined gases as a composite peak. Shortly after this composite peak has passed, the CO is separated from column causing a second peak, while the CO, O, N,

and CH, are being separated in the molecular sieve column². These emerge one at a time through detector 2 (fourth thermistor, T), and provide separate deflections (peaks) on the chart and all except H₂S are therefore, recorded in a process which takes about 4 minutes. H₂S (if any) is seen by detector 1 (T₁) after about 5 min. Both CO, and HS are absorbed by column² and therefore, not seen by detector². The peak heights can be read to 0.2 divisions on a 10 in. chart, which has 100 divisions, so that gases are detected to an accuracy of +0.2% although Units can be improved by scale suppression. A typical chromatogram is shown in figure.

pH METER

The pH value is a measure of hydrogen ions in a solution, and the letters pH stand for "power of the hydrogen ion concentration as represented by the negative logarithm of the hydrogen concentration.

$$\text{pH} = -\log_{10} C_H$$

where $C_H \rightarrow$ Hydrogen ion concentration.

(Pure water has 10^{-7} g of ionised hydrogen per litre,) the pH value is therefore given as 7.

If $\text{pH} > 7 \Rightarrow$ Alkaline solution

$0 < \text{pH} < 7 \Rightarrow$ Acidic solution

$\text{pH} = 7 \Rightarrow$ Neutral point (water)

pH value cannot exceed 14.5 approximately. Screened Cable It is necessary to control the pH of feed water as one of the measures to "O" Ring reduce feed system corrosion, the products of which become a controlled corrosion hazard when transported to the boiler. Boiler water pH is similarly controlled in an alkaline condition to encourage the formation of the protective magnetite film and also to counteract any impurities which may enter the boiler and give rise to BSPT conditions. Outlet Inlet Equipment for pH measurement is shown in figure and the construction of pH meter is shown in figure .

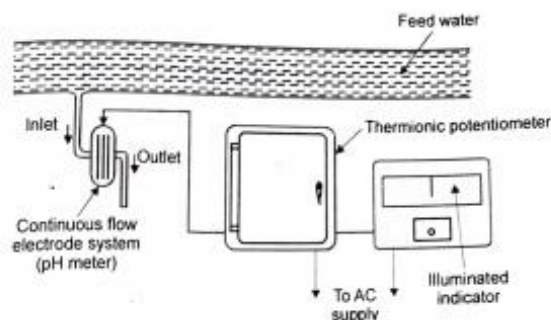

Arrangement of equipment

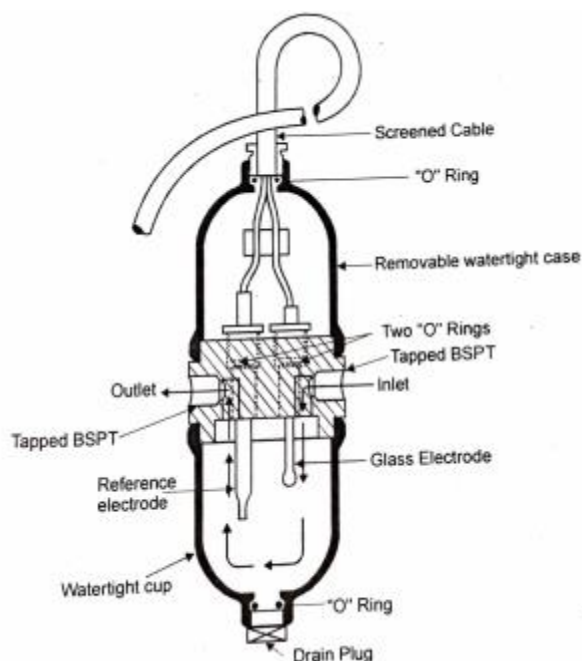

Details of continuous flow electrode system

One electrode is known as the "reference electrode" which, does commonly, contains a paste of mercury and calomel (mercurous chloride), immersed in saturated Potassium chloride solution and with a platinum wire connection to the calomel paste. The whole is contained in a glass tube having a porous plug at some convenient point, through which electrical contact is made with the water to be tested.

The other, or measuring electrode, takes the form of "glass electrode" which is essentially a glass tube, the lower end of which is closed by a thin-walled bulb formed a glass of special composition.

The bulb contains acidic silver chloride solution) and a platinum wire leads upwards out of the tube. The glass bulb is considered to act as a membrane which is permeable only to hydrogen ions.

The emf of the glass electrode varies with the concentration of hydrogen ions in the water, while the calomel reference electrode emf remain constant and the potential difference is therefore a measure of pH value.

The electrical output from these two electrodes is connected via an amplifier, to a potentiometric indicator and recorder. Some continuous monitoring instruments have the glass electrode contained with the calomel electrode in the sampled water flowing through the assembly, which is in a sealed watertight housing as in figure.

Two wires in a single lead are taken to a suitable amplifier and meter. It is essential to comply with the maker's requirements for setting up, standardization and maintenance, in order to obtain reliable readings.

Generation operation memo. No. 72. advices that boiler feedwater should have a pH not less than 8.5 measured at 25°C.

AUTO ANALYSIS

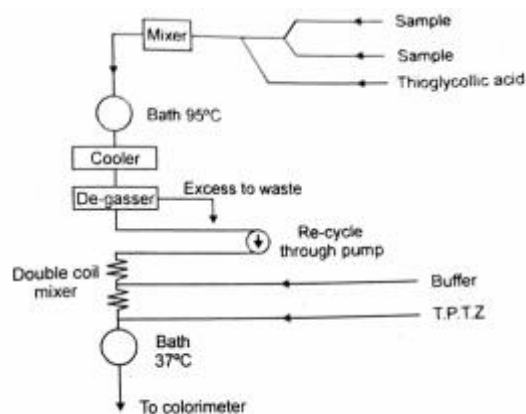

Method for determining Total Iron

The auto analyser uses a continuous flow system which automates the progressive steps of classical wet chemistry" methods and as such can be applied to most of the boiler and feed water analysis required in a power station which depends on colorimetric analysis or any other kind of analysis which finishes with an electrical measurement in some form. It is mainly used to measure continuously chemical parameters which are undergoing continuous change, for sample pick-up of metals like Iron, Copper and Nickel in the feed water during start-up operations. The diagram of Fig. 3.14 represents the arrangements of equipment used for determining total iron in feed water. The basis of the method is that the iron in the water forms a colored complex with TripyryzylTriazene (TPTZ) and the intensity of the colour measured by a colorimeter In incorporating a photocell. The output from this photocell is proportional to the iron present.

in carrying out such an automatic analysis, the solution has to be mixed with chemical solutions in definite ratios, and this is achieved by a proportional pump in which the variation in the rate of flow of the different Chemical solutions is controlled by using tubes of different bore fig. 3.15 illustrates how this proportioning is done in the generalised analyser flow diagram and the method of translating the colour effect in to an electrical signal- for indicating and recording.

Variations of. this auto analyser are available for the of copper, determinatio being nickel, silica, hydrazina, phosphate, etc., the operating principle essentially the same as for iron but using different solutions mixing with the To sample to obtain the characteristic colour.

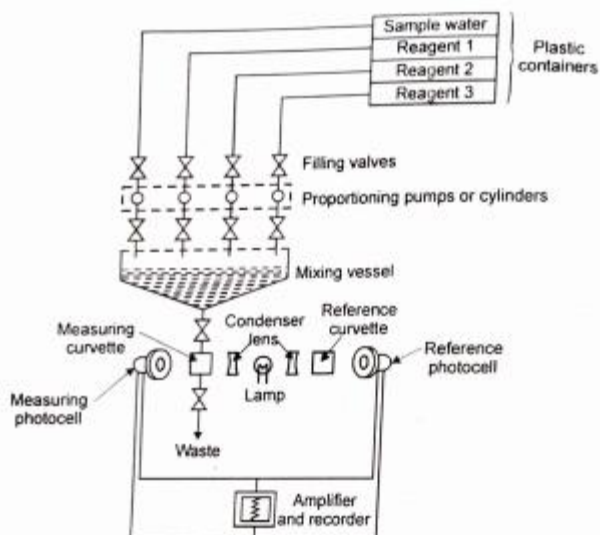

Generalised analyser Flow diagram

FUEL ANALYSIS

Fuels can generally be classified as gaseous, liquid or solid. In cases where a solid fuel is finely ground, such as pulverized coal and can be transported in an air stream, its control characteristics approach those of a gaseous fuel. Liquid fuels, as they are atomized and sprayed in to a furnace, also have control characteristics similar to those of a gaseous fuel. The control treatment of a solid fuel that is not finely ground is quite different from that of a gaseous or a liquid fuel.

Whether a fuel is a gas, a liquid, or a solid is determined by the ratio of its two primary chemical ingredients, carbon and hydrogen (H/C).

Natural gas has an H/C ratio in excess of 0.3

Fuel Oil has an H/C ratio above 0.1

coal has an H/C ratio is usually below 0.07.

Since hydrogen is the lightest element and the molecular weight of carbon is approximately six times that of hydrogen, a decrease in the H/C ratio increases the specific gravity and the density of the fuel.

Gaseous Fuels

The most used gaseous fuel is natural gas, but "waste gas", or gas produced as a process by product may allow the replacement of natural gas or other purchased fuels.

In the iron and steel industries such gases are coke oven gas and blast furnace gas.

In the petroleum refining industry, a mixture of these gases is known as refinery gas.

In the petrochemical industry, such gases may be called tail gas or off gas.

A characteristic of these gases is a significant difference in heat Content and other physical and chemical characteristics as compared to natural gas.

Natural gases vary in their chemical analyses and thus in the heating values. While the average heating value is approximately 1000R per standard Cubic foot (scf), Table 3.1 shows that these gases commonly vary from 950 to over 1100 Btu per scf.

Table 3.1: Selected Samples of Natural Gas from United States Fields

Sample No. Source of Gas	1 Pa.	2 Cal.	3 Ohio	4 La.	5 Okla.
<i>Analyses</i>					
<i>Constituents, % by vol</i>					
H ₂ Hydrogen	-	-	1.82	-	-
CH ₄ Methane	83.40	84.00	93.33	90.00	84.10
C ₂ H ₄ Ethylene	-	-	0.25	-	-
C ₂ H ₆ Ethane	15.80	14.80	-	5.00	6.70
CO Carbon monoxide	-	-	0.45	-	-
CO ₂ Carbon dioxide	-	0.70	0.22	-	0.80
N ₂ Nitrogen	0.80	0.50	3.40	5.00	8.40
O ₂ Oxygen	-	-	0.35	-	-
H ₂ S Hydrogen sulfide	-	-	0.18	-	-
<i>Ultimate, & by wt</i>					
S Sulphur	-	-	0.34	-	-
H ₂ Hydrogen	23.53	23.30	23.20	22.68	20.85
C Carbon	75.25	74.72	69.12	69.26	64.84
N ₂ Nitrogen	1.22	0.76	5.76	3.06	12.90
O ₂ Oxygen	-	1.22	1.58	-	1.41
<i>Specific gravity (rel to air)</i>	0.636	0.636	0.567	0.600	0.630
<i>Higher heat value</i>					
Btu/cu ft @60° F & 30 in Hg	1,129	1,116	964	1,002	974
Btu/lb of fuel	23,170	22,904	22,077	21,824	20,160

Natural gas is the only major fuel that is as it delivered by the supplier is used. The transfer of this fuel to the user usually occurs at a metering and pressure-reducing station as shown in figure.

The pressure reducing valves reduce the pressure from the pipeline suppliers to the pressure required in the users boiler control system. In addition, the gas is metered for billing calorimeter is also purposes, and in many cases installed for recording the heating value of the gas that is supplied.

No fuel preparation is required before the gas enters the boiler plant except for the reduction in pressure.

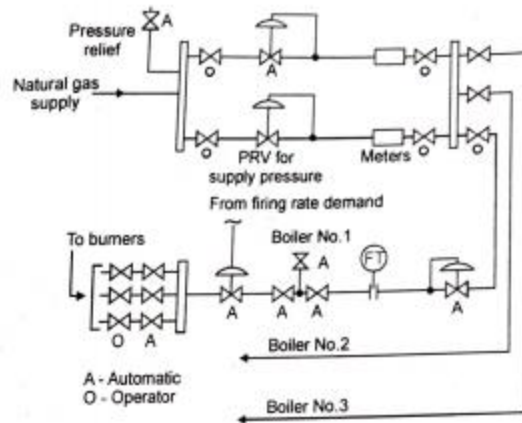

Gas pressure reducing and metering arrangement

In the boiler control system, the regulation of fuel Btu input can be accomplished with a standard control valve. The design of the valve is based on the capacity requirement of the system, the specific gas properties and the pressure drop available for control of the gas flow.

The supply of the "waste gas" streams is usually pressure and /or flow controlled based on the ability of the process to produce the particular gases. A mixture of propane and air is a fuel alternate for natural gas. It will burn in the same burners and under the same conditions as natural gas. A typical system for mixing the propane and air is shown in figure. fuel oil and the No.6 grade of heavy residual fuel oil. The normal random of analyses of these two fuel oils are shown in Table 3.3.

Table 3.3: Fuel Oil Analysis

	No.2	No.6
Carbon	86.1 to 88.2	86.5 to 90.2
Hydrogen	11.8 to 13.9	9.5 to 12.0
Sulphur	0.05 to 1.0	0.7 to 3.5
Nitrogen	Nil to 0.1	-
Ash	0	0.01 to 0.5
<i>Heating value</i>		
Btu/lb	19,170 to 19,750	17,410 to 18,990
Water and sediment	0 to 0.01	0.05 to 2.0
Specific gravity	0.887 to 0.825	1.022 to 0.922
Lb per gal	7.39 to 6.87	8.51 to 7.68

Other liquid fuels that are used as waste or auxiliary fuels are process by-products such as tar, pitch or acid sludge and in some cases, liquid sewage. In some of these cases the heat content alone may not pay for burning the fuel and the economics may be based on a comparison with the costs of other methods of waste disposal

Particularly in pulp and paper mills there is a by-product liquid fuel known as black liquor or red liquor. This liquid is burned in order to recover the chemical content of the liquor. The heat

produced from the combustion of the dissolved "wood" chemicals as the liquor is burned in a boiler. Because the basic process need is chemical recovery, the process is operated to optimize chemical recovery rather than the heat from the combustion of the wood waste content.

If the user is not an oil refinery, the fuel oil is purchased in lots and delivered to the plant by truck, railroad tank car, or oil tanker. The fuel oil is pumped from these tanks and delivered to users fuel oil storage tanks until used. A generic arrangement including the fuel oil preparation is shown in fig. In this arrangement the fuel oil is delivered to the storage tanks. From the storage tanks, the fuel may be taken directly to the fuel preparation equipment, or it may be transferred to a smaller tank, sometimes called a day tank. From the day tank, oil pumps provide the pressure necessary for the fuel control and atomizing system.

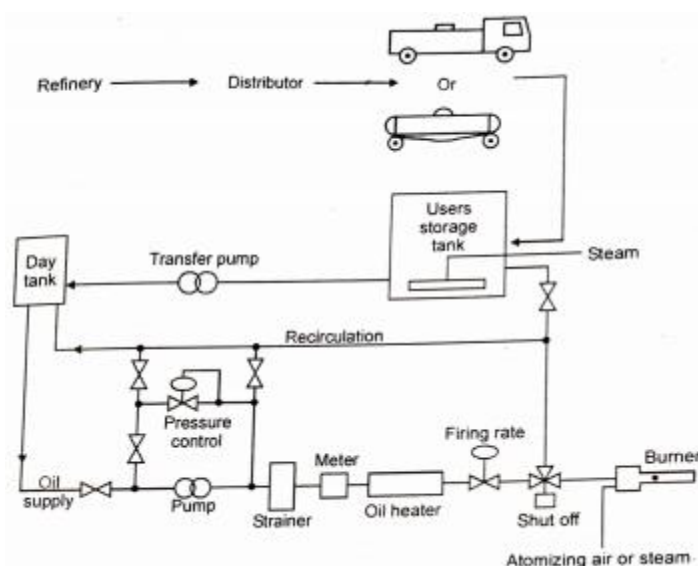

Typical fuel oil pumping and heating arrangement

If the fuel is No.2 fuel oil, heating of the fuel is normally unnecessary. If the fuel is a heavy oil such as No.6, it is usually necessary to heat the oil in the tanks so that it can be easily pumped through the systems. If heavy fuel oil in a tank is unused for a period of time, the tank heating may cause the evaporation of some of the lighter constituents, ultimately making the oil too thick to remove from the tank by any normal means.

Heavy fuel oil must also be heated before burning in order to reduce its viscosity. Fig. 3.19 shows the temperature-viscosity relationship of the various grades of fuel oil. Since most burners are designed for a viscosity of 135 to 150 Saybolt Universal Seconds (SSU), the temperature control of the fuel oil is set to produce the desired viscosity for whatever fuel is being used. From the relationship, the specifications for No.6 oil cover a band of viscosities. Because of this, the correct temperature set point necessary to produce the desired viscosity may vary depending upon the specific fuel characteristics. Solid Fuels The most commonly purchased solid fuel is coal. Coal is available in a number of grades and classifications that vary from bituminous coal.

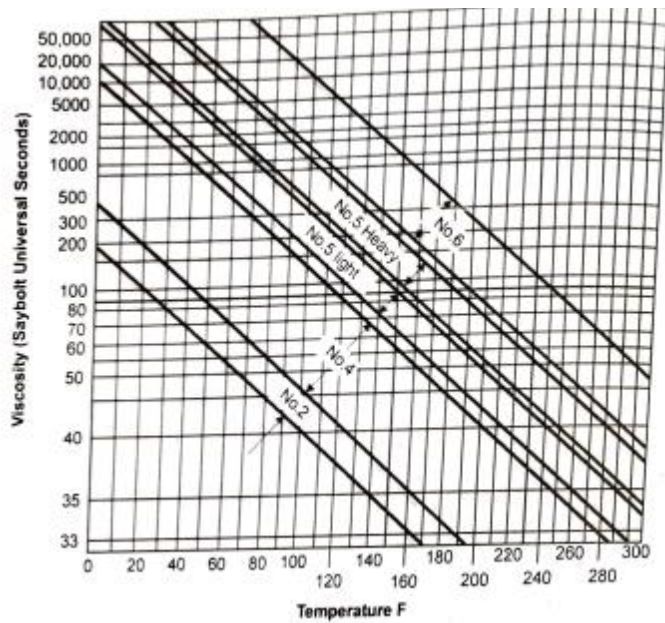

Fuel oil temperature vs. viscosity

with almost 15,000 Btu per lb to a low grade coal called lignite of less than 7,000 Btu per lb. These are two different analyses of coal. i Proximate analysis, is used Primarily for ranking Coal ii) Ultimate analysis, is the analysis of the chemical constituent S by weight percentage and is used in combustion calculations

Table 3.4 demonstrates the difference between the two analysis methods.

Table 3.4 : Coal analysis

<i>Proximate analysis</i>		<i>Ultimate analysis</i>	
<i>Component</i>	<i>Weight, %</i>	<i>Component</i>	<i>Weight, %</i>
Moisture	2.5	Moisture	2.5
Volatile matter	37.6	Carbon	75.0
Fixed carbon	52.9	Hydrogen	5.0
Ash	7.0	Sulphur	2.3
Total	100.0	Nitrogen	1.5
		Oxygen	6.7
		Ash	7.0
Heating value Btu/lb	13,000	Total	100.0

Auxiliary or waste solid fuel is usually a process by product that is burned either for its heating value or for disposal purposes. The most frequently used solid auxiliary fuel is some form of wood waste from wood product manufacturing processes such as Lumber saw mills and pulp and product manufacturing processes such as Lumber saw mills and pulp and paper manufacture. paper pulp and sawdust from a saw mill. The residue of sugarcane (called bagasse) is used in the sugar industry, and coffee grounds are used in Typical of these are the bark from the pulpwood that is made in to plants that manufacture instant coffee. Other solid auxiliary fuel is solid Waste such as municipal garbage or other refuse.

Handling and Delivery of solid Fuels

The various steps in the coal-handling process are shown in figure many "mine mouth" power plants for electric power generation burn the coal essential as it is mined, along with all the dirt and rock that come along with the coal.

Coal used in other electric power generation boilers and in industrial boilers generally follows the steps shown in figure. The coal is cleaned and sized as in the process shown.

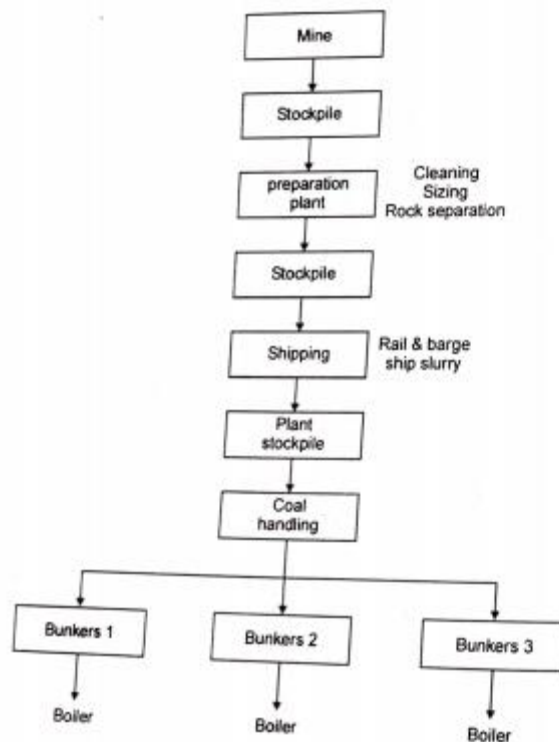

Fuel preparation and handling coal

Since such coal must be shipped to the point of use, this cleaning reduces freight charges. For proper burning of coal with a stoker, the size of the coal lumps is important. The coal bunkers admit coal by gravity directly to the stoker hoppers.

AIR POLLUTION MONITORING SYSTEMS

The development of derivative gas-phase spectroscopy has opened a whole new dimension in gas-phase analysis. As a result, highly specific and accurate gas measurements may now be made in complex mixtures such as urban air. By eliminating both the need for extensive sample conditioning and the lengthy time lags between sampling the air and obtaining useful data, gas-phase derivative spectroscopy makes it possible to study gaseous mixtures and their behavior in real time and without secondary reactions or sample alterations

The features and benefits inherent in this measurement technique preparation plant Cleaning Sizing Rock separation are now available in a family of instruments designed specifically for monitoring pollutant levels in urban or clean air. These instruments combine number of performance oriented features to provide highly accurate, specific, reliable and continuous measurements of the concentrations of NO,NO₂,SO₂, or NH₃, in the atmosphere.

The technique of tuned, second derivative spectroscopy is particularly well-suited to measurement situations where continuous monitoring of the concentration of a specific compound is required in a very complex and frequently changing mixture of gases.

This is especially true for the duty profile of ambient-air monitors. Air monitoring system are available to meet this demanding duty profile and solve the complex measurement requirements for continuous air monitoring, regardless of regional variations of special atmospheric problems.

Derivative Spectroscopy

Derivative spectroscopy is concerned with the shape characteristics, rather than with the basic intensity changes, of a spectral absorption distribution. The slope and curvature characteristics are often quite large, very specific and largely independent of intensity. Because these show Characteristics are large, yet specific to individual compounds, extreme complex separations of component gases are possible, while the sensitivity. Over conventional spectrometric techniques increases by several decade The Air Monitoring systems make full use of these advantages and open the way for monitoring ambient air where previously available techniques have been unsuitable due to their lack of specifically, low end sensitivity, or excessive analysis time.

In these instruments, the light radiation emitted by an ultraviolet or visible source is spectrally dispersed by a grating monochromatic, providing essentially monochromatic light in the sample cell as shown in figure.

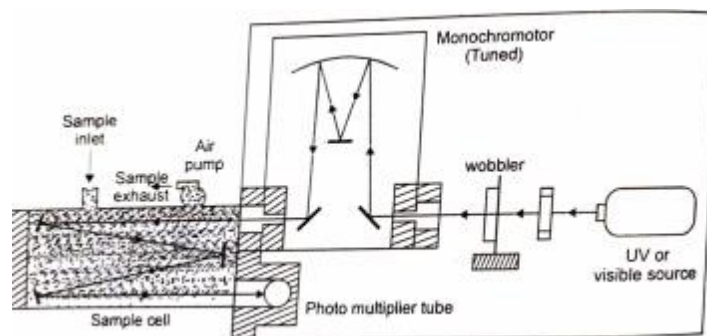

Air pollution monitoring equipment

The wavelength of this monochromatic light is varied with respect to time by a literally oscillating monochromatic entrance slit ("Wobbler"). Electro-mechanical displacement of the wobbler is sinusoidal at a frequency of 45 hertz and has a peak-to-peak displacement of 1/4 to millimeter, depending upon the desired amplitude of wavelength modulation. Therefore, the radiation entering the sample cell has a wavelength established by the positioning of the grating, but it modulated with also respect to time. For example, if the amplitude of wobbler oscillation is 1/2 millimeter, the wave length is modulated 10 angstroms at 45 hertz. The 1/2 metre sample cell contains three spherical mirrors in "white cell" arrangement. Diverging light enters the sample cell from the monochromatic and is collected by a mirror at the far end of the cell. This mirror focuses the light at a point on the mirror at the near end.

The light then diverges to the second mirror at the far end of the cell and is, in turn, focused at a new position on the near end mirror. This process can be repeated as many as 32 times, but in normal operation, light passes through the sample a total of 12 times (6-metre path length). Finally the light exits the sample cell and is focused on a photomultiplier tube.

Since the second_ derivative function is proportional to the second harmonic of the 45-hertz input frequency, the output signal from the photomultiplier tube is electronically analysed for its 90-hertz component. Generally, this components amplitude is small in comparison to the total DC output voltage and is buried in noise

However, a coil fixed to the oscillating wobbler and moving in a magnetic field provides a reference signal having the exact frequency and phase of the wavelength modulation. By electronically doubling the frequency of the reference signal, the instrument locks in on the frequency and phase of the 90 hertz photomultiplier output component.

Using these standard phase-lock amplifier techniques, the instrument presents a DC voltage representative of the amplitude of the 90-hertz signal component. This DC voltage is proportional to the second derivative of intensity with respect to wavelength (curvature).

To obtain a signal proportional to the gas concentration, the Second derivative voltage signal is electronically divided by the total output voltage of the photomultiplier tube, providing the desired voltage ratio.

Each absorption peak indicates the presence of an absorption a particular wavelength at which a given molecule absorbs energy of ultraviolet or visible radiation and makes a transition from one state to another (resulting in a new geometrical configuration of the molecule).

Unlike infra-red absorption bands that are low energy transitions the ultraviolet and visible bands are relatively insensitive to effects of temperature and pressure.

The air monitoring instruments operate on the same principle, except that they do not scan the spectrum. Instead, their centre wavelengths are fixed ("tuned") to a previously identified peak that is characteristic of and unique to the compound being analyzed as shown in figure. The height of that peak is then a direct measure of the compound's concentration.

UNIT – IV

BASIC CONTROL LOOPS IN BOILER

Simple Feedback Control

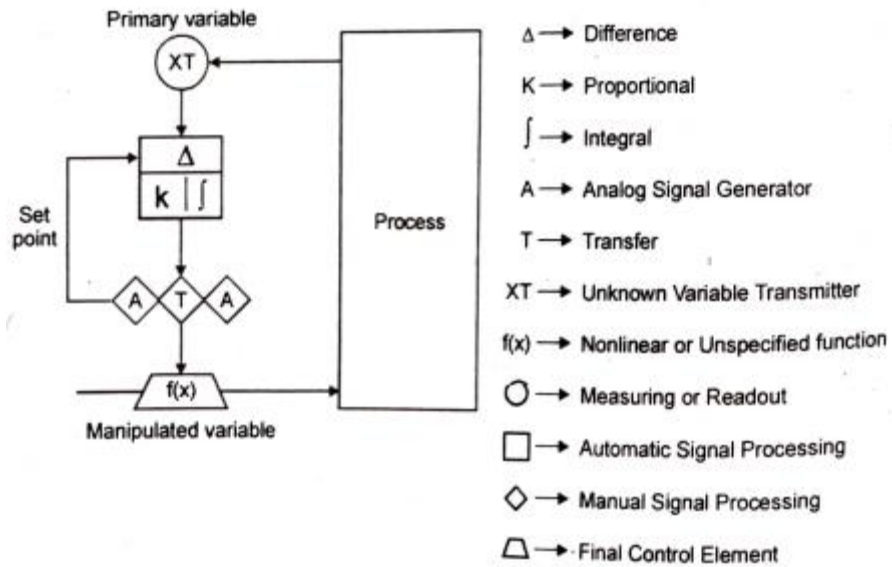

Simple Feedback Control

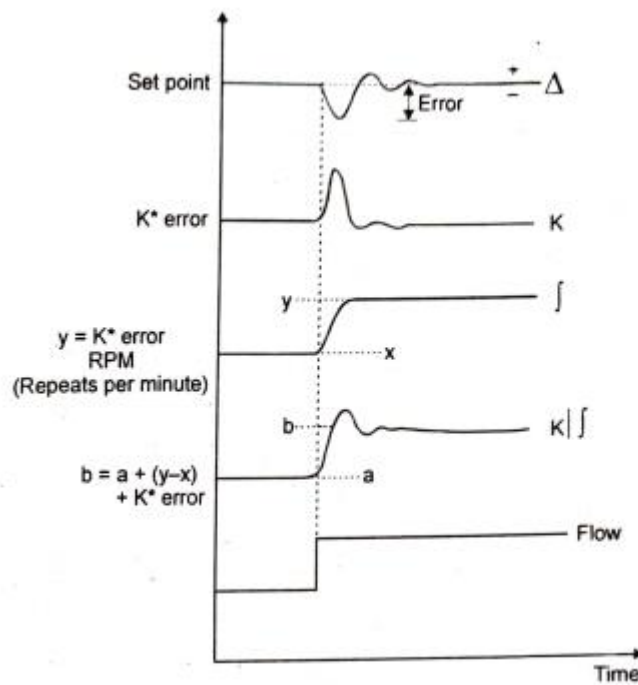

Proportional - plus- Integral control

Simple Feedback Control is shown in the control diagram of Figure. With this type of loop, changes in the primary variable feedback to a control function, as shown.

The control function can be Proportional plus - Integral (as shown), Proportional only, Proportional plus - Derivative, Integral only, or Proportional - plus - Integral plus - Derivative.

In all these cases the controller includes the error detectors function, which measures the error between the primary variable and the set point.

The controller output is determined by a combination or summation of the effects of the different control action capabilities that are built in to the controller. These are the proportional or gain multiplication of the error magnitude, the difference between the measured amount and the set point, the integral action based on incremental time away from set point multiply by error magnitude and the derivative or rate of change of the measure variable. A change in the controller output changes the manipulated variable. Which through action of the process changes the process output selected as the primary variable? This closes the control loop. A time-based diagram of the control action components for a in repeats Proportional-plus-Integral Controller is shown in figure. The first a minute, minutes per repeat, or seconds per repeat. Component of the control action is the Proportional controller.

The error or magnitude of the difference between the process variable and the set point is multiplied by the proportional gain, one of the controller tuning adjustments.

This gain may be expressed directly as a multiplies or in terms such as "Proportional Band". In the case of proportional band, the value divided in to 100 is equal to the gain or error multiplier. As the error increases and decreases, the effect of this control component changes in direct proportion.

The tuning constants that are set in to the controller are affected by the measurement ranges, the dynamics of the control loop and the capacity of the manipulated variable for effecting change.

The measurement range of the measured variable determines the magnitude of the basic error signal with respect to set point. The capacity of the controlled device determined the amount of manipulated variable change for each increment of control signal change.

The Proportional gain or multiplier essentially gears the measured and manipulated variables in to proper balance so that a measured variable error will produce the desired magnitude of change to the manipulated variable.

The desired proportional gain value is the highest value of proportional gain that results in stable conditions of the measured variable and with change aspects of the manipulated or other variables that also result in most desire conditions.

Nearly perfect steam pressure control of a boiler may be stable but may result in considerable oscillation of the fuel and combustion air, an undesirable operating condition. To reduce these oscillations would require reducing the gain and accepting some deterioration in the steam pressure control.

The second component of the controller output is the integral value. The integral setting value is time-based and closely relates to the process

There is more than one method of computing (algorithm) for the integral. The most common is integration with respect to time of the error multiplied by the gain. If seconds per repeat is used and the controller setting is 10 seconds per repeat/ then after 10 seconds the controller would have added K (controller gain) times the error from set point to the controller output. Another common algorithm integrator only the error value and does not use the proportional gain.

In the case of Figure, assume that, as time starts, the loop is stabilized, at set point, the measured variable is pressure, the pressure sensor has a range of 0- 400psig and the set point has a value of 200psig.(The controller has been tuned, the proportional gain is 2.0/ and the integral setting is 0.5 repeats per minute.

At the end of (x) time, the system flow capacity changes, the pressure begins to deviate from set point and a change to the manipulated variable is necessary to return the measured variable to the set point. The diagram shows that when the controller returns to set point the error is 0. Therefore any effect of the proportional gain is also reduced to zero. The proportional gain effect is, therefore, temporary and has a value only when the process variable deviates from the set point. The value of the integral portion of the controller output is, however, permanent and with the process variable at a steady state and at set point, is equal to the controller output. If this had been a proportional-only controller, an offset from set point would have to be maintained to satisfy the need for a permanent change in the controller output.

Feed forward Plus Feedback Control

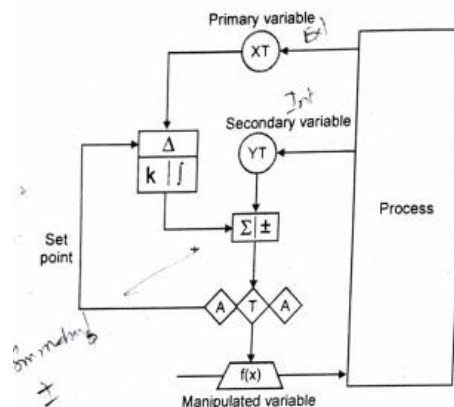

Feed forward -plus-Feedback control

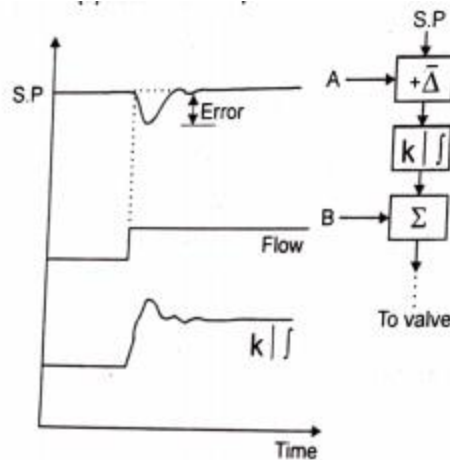

Feed forward-plus-Feedback control

In feed forward - Plus -Feedback Control is as shown in figure , a secondary variable that has predictable relation-ship with the manipulated variable is connected.

In this case, a change in the secondary variable causes the manipulated variable to change in anticipation of a change in the primary variable. This Primary variable reduces the magnitude of the change due to the more timely control action that originates from the secondary variable.

The feedback portion of the loop contains the set point and can contain any of the controller functions of the basic feedback loop. The feed forward gain is adjustable and may be greater than 1.0. In figure , a time-based diagram based on the use of feed forward plus-feedback control is shown. In this case, a change in the signal from the secondary variable acts without waiting for the primary variable to change.

The goal is to calibrate the feed forward portion of the control so that the primary variable does not change value. This is done by changing the gain or multiplier of the secondary variable so that its change multiplied by its gain produces a change in the feed forward portion of the controller output that is equal to the permanent steady-state change in the controller output. If this can be accomplished, then there is no permanent effect on the controller output from the feedback portion of the controller.

This net result is very similar to that of Proportional plus - Integral control except that the required magnitude of the controller action takes place in less elapsed time. In this case, the feed forward action essentially replaces the integral action, so that theoretically the feedback controller needs only proportional action.

Cascade Control

Cascade control consists essentially of two feedback control loops connected together with the output of the primary loop acting as set point for the secondary loop.

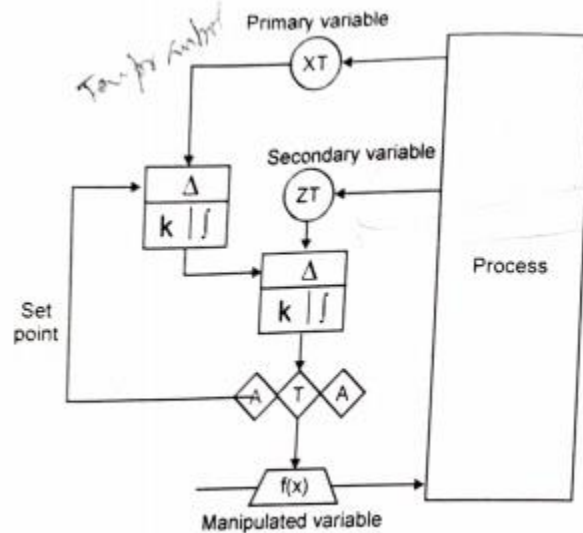

Cascade Control

Cascade control shown in figure is applied to stabilize the manipulated variable so that a predictable relationship between the manipulated variable and the primary variable can be maintained.

To avoid control instability due to interaction between the two feedback it is necessary that the response time constants be substantially different. The process response of the secondary control loop should be the faster of the two loops.

A general rule is that the time constant of the primary loop process response should be a minimum of 5 to 10 times that of the secondary loop. The longer time constant of the primary loop indicates a much slower response.

Because of this, a normal application would be temperature control a normally slow loop) cascading on to flow control (a normally fast other loop). AIS applications are temperature cascading on to pressure control and control cascading on to flow control.

Ratio Control

Ratio control consists of a feedback controller whose set point is in direct portion to an uncontrolled variable as shown in figure. The proportional relationship can be set by the operator of the process, or it can be automatically adjusted by another controller.

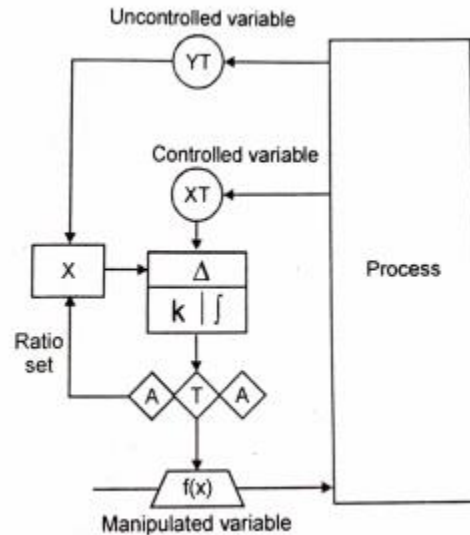

Ratio Control

As shown, the mathematical function is a multiplier. If the ratio is set, the set point of the controlled variable changes in direct proportion to changes in the uncontrolled variable. If the multiplication is changed, the direct proportional relationship or ratio between the controlled and the uncontrolled variables is changed.

A careful examination of most boiler control applications will show that the overall control system is an interconnected matrix of the four types of control application shown in figures.

COMBUSTION CONTROL

Physical Combustion Requirements Combustion is the rapid oxidation of fuel in a mixture of fuel and is with heat produced and carried by the mass of flue gas generated. Combustion takes place, however, only under the conditions shown in figure

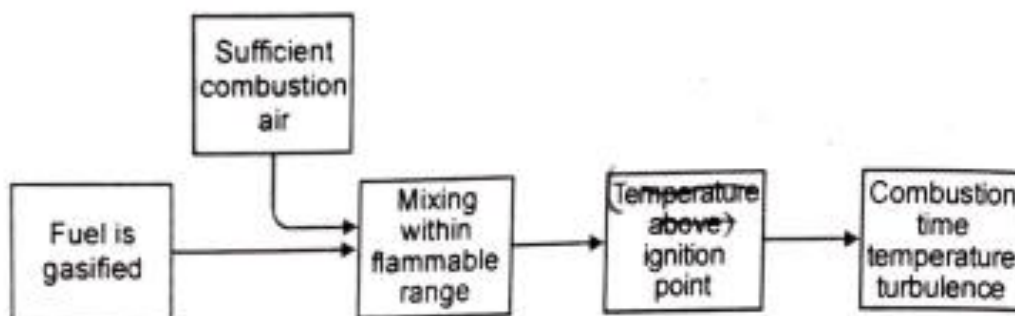

Combustion Requirements

Time, temperature and turbulence are known as the three "T" s of combustion. A short period of time, high temperature and very turbulent flame indicates rapid combustion. Turbulence is a key because the fuel and air must be mixed thoroughly if the fuel is to be completely burned.

When fuel and air are well mixed and all the fuel is burned, the flame Flue gas temperature will be high and the combustion time will be shorter. When the fuel and air are not well mixed, complete combustion may not occur, the flame temperature will be lower and the fuel will take longer to burn.

Less turbulence and longer burning has, however, been found to produce fewer nitrous oxides (NO_x). In some cases, combustion is delayed or staged intentionally to obtain fewer nitrous oxides or to obtain flame characteristics.

The fuel must be gasified. In the case of natural gas, this is automatically true. For oil, the fuel must be atomized so that the temperature present can turn it into a gas. When coal is burned, the coal must be pulverized so that it can be gasified by the furnace temperature or distilled in suspension or on the grate by the furnace temperature of a stoker is used.

Combustion Chemistry and Products of Combustion

For all fuels, the actual chemical process is the oxidation of the hydrogen and the oxygen is the fuel by combining them with oxygen from the air. The nitrogen from the air and any other non-combustibles in the fuel pass through the process with essentially no chemical change. A minimal amount of nitrogen in the air combines with oxygen to form nitrous oxides (NO_x), which pollute the air. Some fuels contain a small percentage of sulphur, which-when burned-results in sulphur oxides that pollute the air. These may also corrode the boiler if the flue gas containing them is allowed to cool below the dew point.

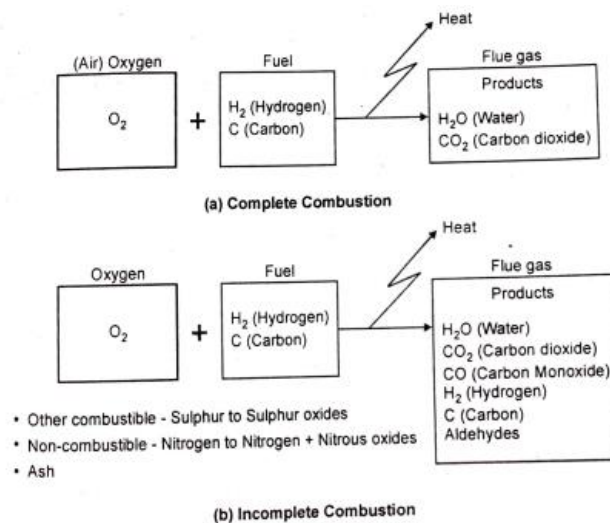

Combustion Chemistry and Products of Combustion

Figure demonstrates the basic chemical process and the chemical elements and compounds involved in complete and incomplete combustion. For any fuel, a precise amount of combustion air is needed to furnish the Oxygen for complete combustion of that fuel's carbon and hydrogen.

The precise amount of combustion for air is called the theoretical air for that particular fuel. If the fuel analysis. Air requirements can be calculated easily.

METHODS OF COMBUSTION CONTROL

Single Point Positioning Control

A single point positioning or "jackshaft" system is a mechanical one as shown in Figure. The position of the fuel control valve and the combustion air flow damper are connected together in a fixed relationship and move in uniform to the demands of the master regulator.

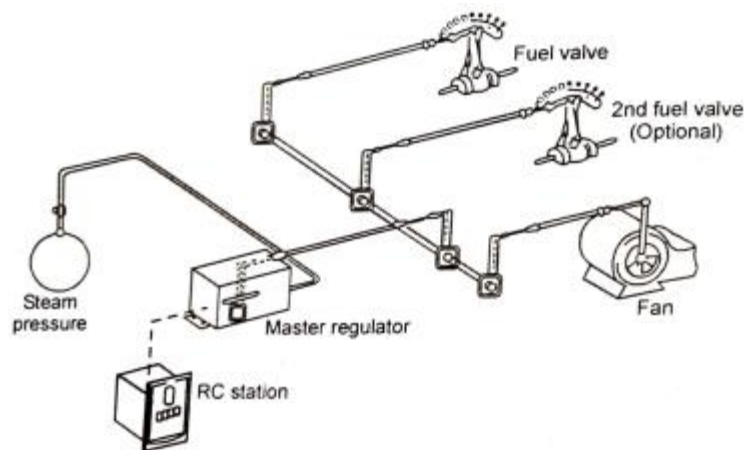

Single - Point Positioning Control System

A basic requirement of this type of system is the careful mechanical alignment of the fuel valve and the air damper positions. Fuel valves and air dampers tend to have different flow characteristics. Typical characteristics are shown in figure .

If the master regulator were to move each to the 50% position, then air flow for approximately 75% capacity would be provided while fuel for 2b capacity was being supplied.) By making the flow characteristics linear, they can then be aligned.

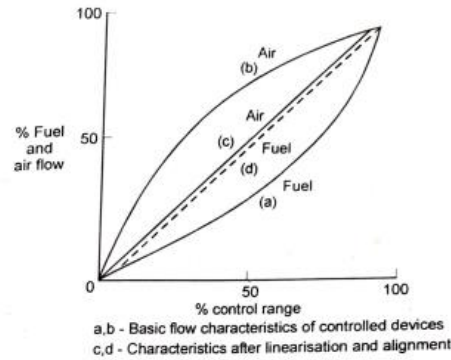

Flow Characteristics of Valves and Dampers

In the case of the air damper, the alignment tool is the use of linkage angularity. In the case of the fuel flow, the control valve is usually supplied with a cam arrangement for changing the perceived flow characteristic.

The procedure is to linearise the air flow characteristic and then to Steam match the fuel flow characteristic to that of the air flow. To perform this alignment procedure properly, it is necessary to perform combustion tests at pressure Master regulator ORC station several different boiler loads. Although the single-point positioning system is mechanically linked, a flue gas analysis trimming control loop can be applied to control the fuel/air ratio and reduce the control error band figure shows some typical arrangements for applying the trimming control.

Other methods include changing the length of the link to the combustion air flow damper, changing the length of the drive arm connected to the link, or both. In all these arrangements the control signal from the trimming control originates, in the control loops. If there is a significant error in the basic system, the trimming control requires time to make the adjustment.

If the basis system error is different at one load than it is at another load, time time is required to readjust as the load is changed. This is usually not a problem unless the boiler load changes rapidly. In such cases the trimming probe unless center may have difficulty keeping up with the changes in excess air. This problem is demonstrated in figure.

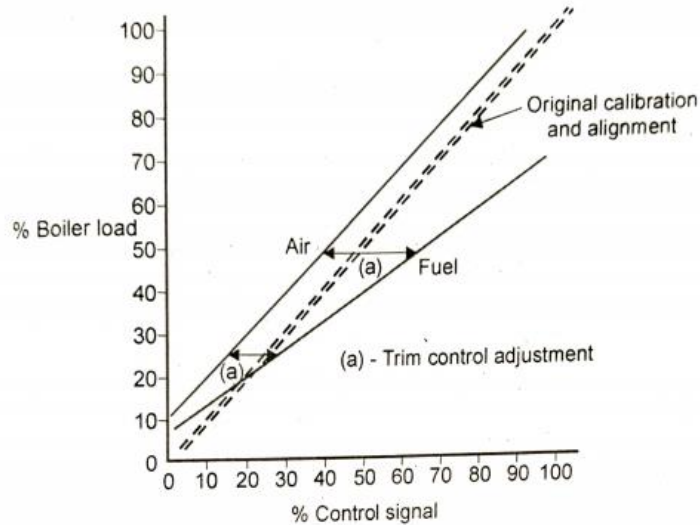

Alignment Problem: Air is Cold, Fuel Pressure is Low

As shown in this plot, at 50% load, the trimming correction due to error in the basic system is 25% and is 12.5% at 25% boiler load. The controller output, therefore must change by 12.5% as the boiler load is changed. Some microprocessor-based "trim" control arrangements use memory of last time at this load vs. trim signal relationships to help move quickly to a new output signal as the load is changed. The plot also demonstrates that poor alignment of the basic system may create the need for an excessive amount of correction from the flue gas analysis trim control. In such cases trim control limits may prevent the amount of correction that is needed.

Parallel Positioning Control

The functions shown in the mechanical single-point positioning arrangement are also performed using instrumentation control. Such systems called Parallel Positioning Control Systems/ link the functions pneumatically or electrically. A SAMA control logic diagram of a parallel positioning system is shown in figure.

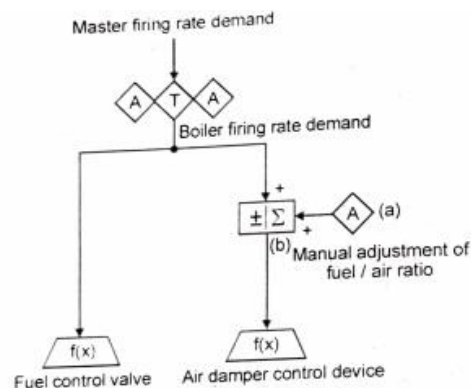

Parallel - Positioning Control System

Such control systems must be aligned in the same manner as the single point system. In this case, a cam in the positioner of the fuel control valve is used to linearise fuel flow and align it with air flow.

For air flow calibration, linkage angularity and/or the cam in the positioner of the damper operator may be used to linearise the air flow signal Vs. flow.

A parallel positioning system has the same weaknesses and same control error band as the single-point system. Note that such a system may have simple means of biasing the fuel/air ratio through use of the manual loading function, (a) in figure .

This adjustment means is useless without the use of a flue gas analyzer or some other form of combustion guide as shown in figure. In order for the system to be aligned with the operator adjustment in the midpoint of range, the firing rate demand input to summer (b) is set at a gain of 1.0

Assuming that the operator is provided a plus or minus 15 percent Dia, the gains of the input from (a) is set at 0.3. With both inputs at 50%, and with no bias, the output of summer (b) would be 65%. The bias in summer (b) is then set at minus 15% so that the signal to the air damper control device will always match the firing rate demand signal.

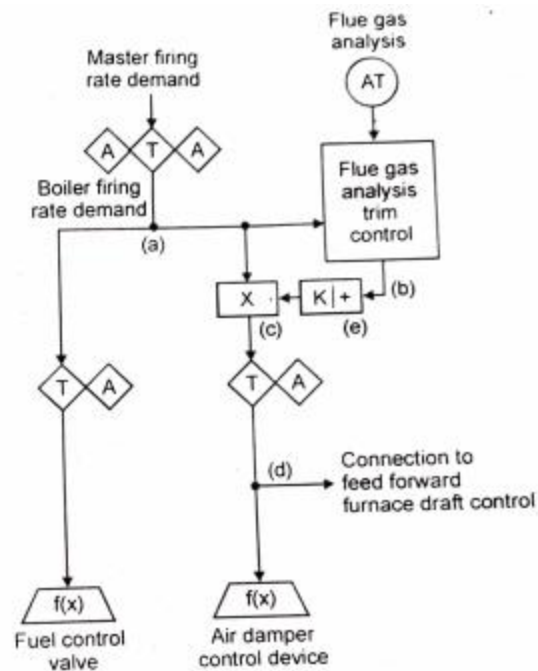

Parallel - Positioning Control with Flue Gas Analysis

The ease with which a boiler operator makes such a fuel/air ratio adjustment also makes it easier for the operator to cause system misalignment. One advantage of the parallel system is that the timing of a fuel flow change or an air flow change can be modified by inserting a time constant

in to either of the two control signals to improve matching of actual fuel and air flow to the furnace. This makes possible improved dynamic operation.

The bias and gain functions (j) are added to provide a small 3 to 4% dead between the applications of the high and low select functions. This addition prevents the effect of process measurement "noise" from causing altercation between the fuel flow and the air flow control loops.

The addition of the manual signal (k) connected to the high select (1) provides a minimum air flow control capability by preventing the air flow set point from being reduced below 25% of fuel range.

This diagram also shows the application of a flue gas analysis trim control loop replacing the manual fuel/air ratio adjustment. By its control action, the air flow measurement signal (e) is continuously calibrated so that the programmed flue gas analysis will be obtained.

The firing rate demand signal (a) is used as the "boiler load" signal in the arrangement shown. The fuel flow signal (d) or a steam flow measurement signal could also have been used.

The points marked A, B and C are the points at which this control system arrangement can be easily be modified for application to the use of other fuels or fuel combinations or for other air flow control arrangements.

The control system alignment consists of:

- i. Calibration of the air flow function generator (n);
- ii. Setting the bias values of approximately +25% and gains of 1.0 to items)
- iii. Setting the minimum air flow signal (k) at 25%; and
- iv. Setting the gain of proportional plus bias (0) to 0.3 and setting the bias to plus 85%

After the alignment procedure, the next activity is to tune the flow Controllers (b) and (c). This procedure is typical of the tuning of any flow Control loop. The optimum gain setting will probably be in the 0.5 range and the optimum integral setting will probably be several rpm (repeats per minute).

Dynamic load change excess air during the load change. In this case, either the fuel testing may reveal a in the desired control loops should be detuned until their dynamic response is the same. The 25% bias values of items g) avoid any effect from the limiting control during this tuning period. After the flow controller tuning operation, these settings are adjusted to their operational settings. This is accomplished by gradually reducing the bias values until interaction with the flow controllers is indicated. This will normally show up best as the process noise band of flue gas analysis.

MEASUREMENT OF FURNACE DRAFT

Figure demonstrates the choice of pressure tap locations for measuring furnace draft. The pressure connections on most boilers are located on the front, side, or roof of the furnace.

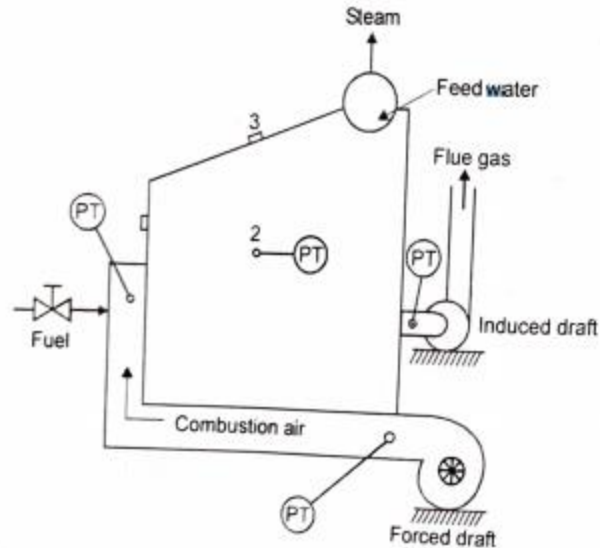

Measurement of Furnace Draft

Although the measurements at these three locations would be for same th furnace chamber of a particular boiler, the measurement values would differ due to the differing stack or chimney effects.

The measurements at different elevations will differ by approximately a01 inch H₂O per foot elevation. The measurement in the roof of the furnace will be the highest value. Since it is necessary to have negative pressure at all points, the value at the furnace roof becomes the controlling factor in determining the desired set point for the control of furnace draft.

Thus, if the pressure at the furnace roof is to be minus 0.1 inch of H₂O and the connection ior measuring furnace draft is located at an elevation 15 feet below the furnace roof, then the set point for this control loop should be approximately - 0.25 inch of H₂O. On a larger boiler the connection might be as much as 50 feet or more below the roof elevation. In this case, the set point should be approximately -0.6 inch of HO or at a lower pressure.

Furnace draft measurement is also subject to considerable process "noise". The use of a narrow range transmitter tends to accentuate the effect of such noise in the measurement. An additional factor is primarily a limitation of analog control. In this case it is quite often impossible to reduce the controller gain to a low enough value. Therefore, the general practice is therefore to use a control transmitter range of approximately +1.0 to - 5.0 inches of H₂O.

Draft is defined as a "Current of Air": Associated with this meaning is its definition as an air or flue gas pressure that is slightly negative with respect to atmospheric pressure. When in a conduit connected to atmospheric pressure, such negative pressure would create a current of air or flue gas.

Draft Loss: Draft loss is the difference in draft or pressure resulting from the flow of the air or flue gas through a system that includes the boiler furnace, ductwork and various types of heat transfer surface.

Natural Draft: (Natural draft is a term used when the air flow through the Figure boiler is a result of the stack effect in a chimney or stack.

Forced Draft: In the case of boiler, a fan or air blower that takes suction from the atmosphere and forces combustion air through the system called as forced draft.

The controller is thus quite insensitive to process noise and also the required control action when close to set point. This also tends to accentuate the problem of the series time delay.

For comparison purposes, figure demonstrates the performance of a typical feedback furnace draft control loop. The excursions tend to be large with respect to the set point value and the control tends to be unstable due to the effects of the process noise.

Assuming 60 a measurement at the furnace roof, the goal is to hold the furnace draft to a set point of -0.1 inch of H₂O with an excursion range of 0.05 inch of H₂O, while the process noise is usually a minimum of #0.1 inch of H₂O and a typical overall capability of the fans at 6 to 10 inches of H₂O.

Furnace Draft Control using Feed forward-Plus-Feedback Control

The simplest form of the furnace draft control loop uses a Feed forward Plus-Feedback control loop is as shown in figure .

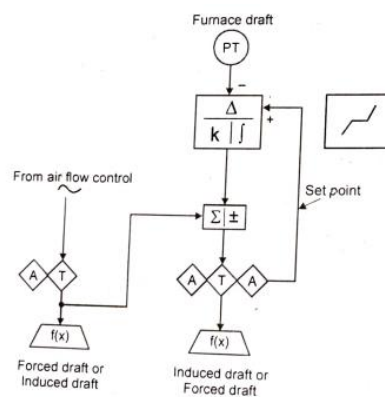

Furnace Draft Control (Feed forward-Plus-Feedback Control)

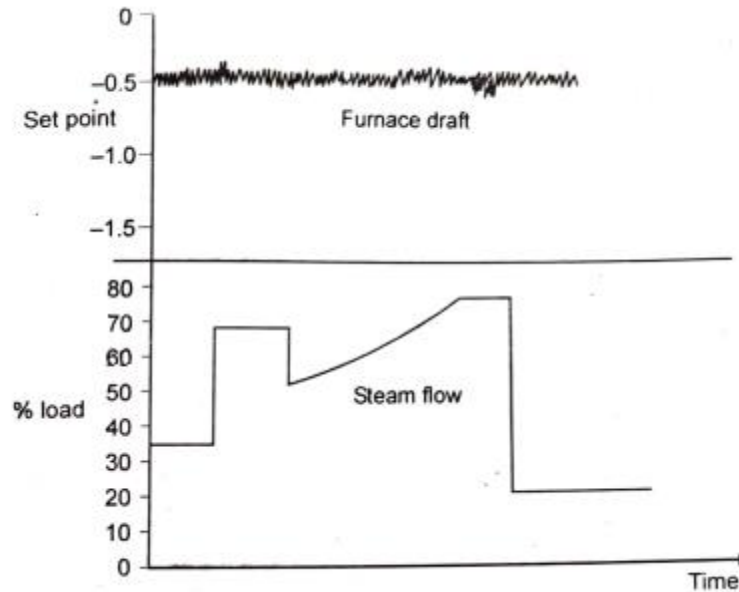

Furnace Draft Control (Feed forward-Plus-Feedback Control)

In this case, the signal to the forced draft control device is added in the Summer (a) to the output of the furnace draft feedback controller. So the series time lag between forced and induced control action is eliminated.

It is necessary to provide a bias function in the summer (a) so that the output of the furnace draft controller will operate normally in the middle portion of its output range. This allows the controller to equally add or subtract from the feed forward signal as necessary.

A proper control alignment for the summer (a) would show it having gains of 1.0 on both inputs and with bias of -50 percent. It is necessary to parallel the flow characteristics of the two parallel Control devices (in this case forced and induced draft). If this is not done, the two will not provide the proper parallel effect, and much of the benefit of the feed forward control may be lost. It is also necessary to select the proper feed forward signal. Measured air flow should not be used as the feed forward signal.

DRUM LEVEL CONTROL

Drum Level Control objectives (Feed water control objectives)

Control the drum level to a set point.

Minimize the interaction with the combustion control system

Make smooth changes in the boiler water inventory as boiler changes.

Properly balance the boiler steam output with the feed water input

Compensate for feed water pressure variation without process 100 Interaction with upset or set point shift.

Single-Element Feed water Control (Simple Feedback Control)

By using simple feedback feed water control as shown in figure we can able to reduce the controller gain results in less interaction with the firing rate control in order to upgrade the boiler efficiency.

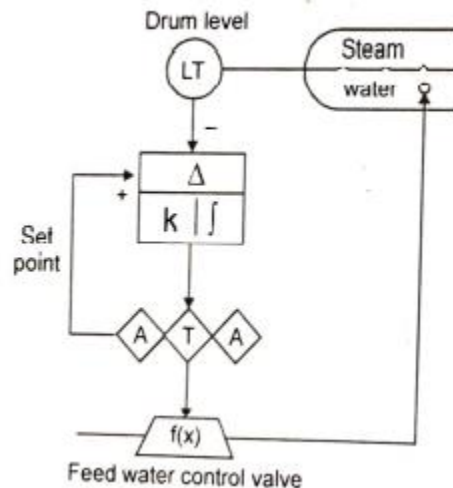

Simple Feedback Feed water control (Single-Element Feed water Control)

If the controller is proportional only, a greater drum level offset would occur as boiler load changed. Since the low to high load level change approximately 4 inches, it can be assumed that a 0-100 percent flow change is assuming a typical measurement range of 30 inches, the he gain of this controller would be 6.0./This gain would produce greater stability and less interaction but also twice the proportional offset stability and less interaction but also twice the proportional offset. To avoid this unsatisfactory condition, integral control is added. The integral effect must be quite slow since the level signal moves incorrectly at the times of boiler drum level swell and shrink.

The result is as shown in figure . The specific improvement is that the level will return to set point, incorrect action of feedwater flow during load changes is reduced, and the system is generally more stable and less interactive with the firing rate control. Set k point The controlled device, whether a control valve or pump speed control device, should have a linear signal Vs. flow characteristic as shown in figure The basic reason for this is that drum level deviations around Feed water control valve the set point represent a specific quantity of water over the entire boiler oad range. In the case of signal vs. pump speed, this must be nonlinear, as shown, in order that the control signal vs. water flow be as linear as possible. The large increase in pump

speed for an initial small increase in control Signal brings the pump speed up to the required pressure for admitting water in to the boiler.

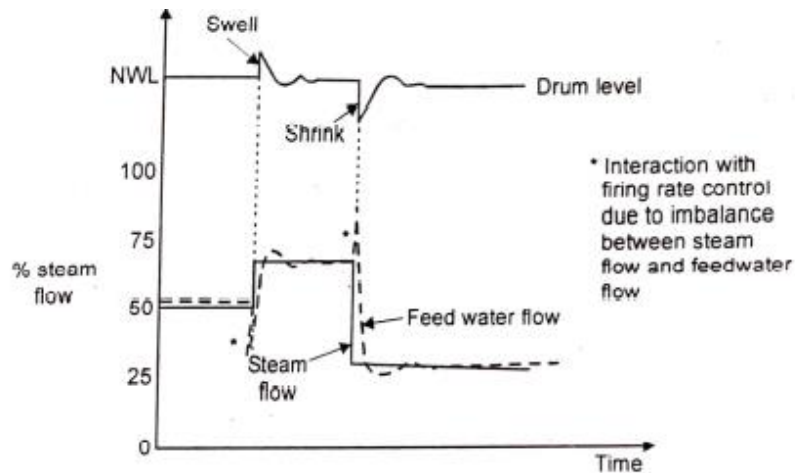

Control Action of Simple Feedback Feedwater Control (Single-Element Feedwater Control)

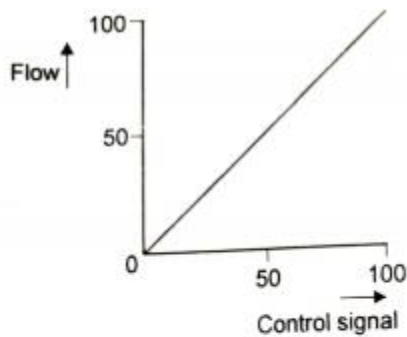

(a) Control Valve - desired characteristic

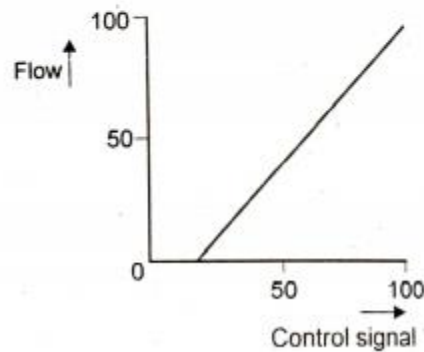
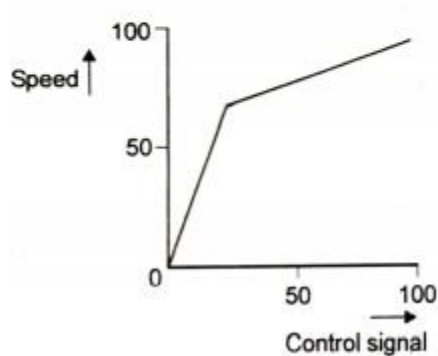

(b) Pump Speed-desired characteristics

Feed water Control Device Flow Characteristics

Two-Element Feed water Control (Feed forward-Plus-Feedback Control)

A two-element feed water control system is shown in figure. This is easily recognized as a standard feed forward-plus-feedback control loop. In this case steam flow is the feed forward signal that anticipates a need for additional feed water flow. The feedback control from drum level is shown as proportional - only control. The control valve is characterized so that the control signal Vs. feed water flow is linear. For this system to perform properly and drum level at the set point, it is necessary that the differential pressure across the feed water control valve be predictable at each flow and that the valve signal vs. flow relationship does not change.

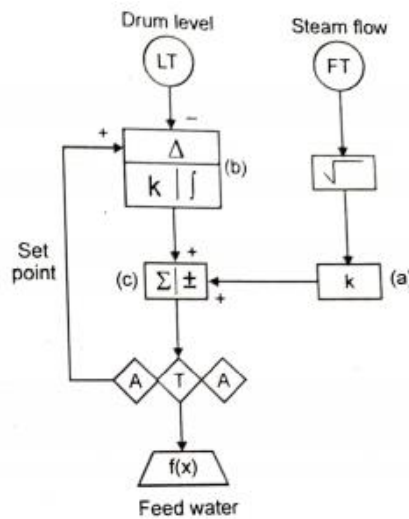

Two-Element Feed water Control System (Feed forward plus Feedback)

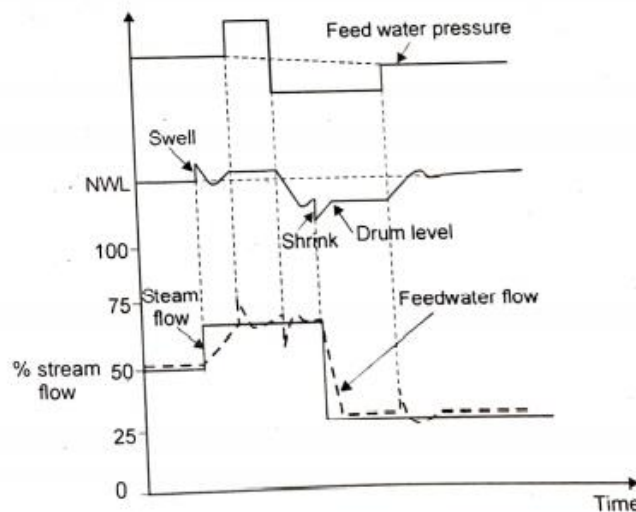

Effect of Feedwater Pressure Variation

flow in a feed water control system, spray water Flow must be added feed water flow or subtracted from steam flow.

The total pressure drop available for the superheat spray system is summation of to pressure drops across piping, the two high pressure heat the economizers inlet, up to the economizer, and the primary super heater This must match the pressure drop across the spray nozzle, the s water control valves, unrecovered pressure drop across the flow measurement Vent primary element, friction in the spray water piping and the elevation Water eam difference in head at spray water conditions between the source and the steam line.

The control system has only the control valve pressure drop to work heater and storage| with and this is often a relatively small percentage of the total. This contributes to the problem of non-repeatability between control valve position and flow. In some cases, it may be necessary to install an auxiliary spray water pump to obtain enough valve pressure drop for good control.

HEATING AND DEAERATION

A typical boiler feed water supply system consists of three basic parts: Boiler Feed Pumps

1. A set of boiler feed pumps Feed water header
2. Valves, feed water piping and headers
3. Feed water heaters

This system is supplied with condensate or chemically treated water at a relatively low temperature. The heaters and boiler feed water pump condition the water for proper admission to the boiler. The piping and headers connect the feed water supply, heaters, valves and pumps to the boiler.

Figure shows a general arrangement of a basic feed water supply system. The relatively cool water is admitted to the deaerating heater. Water leaving the heater is deposited in to an integral heated-water storage tank.

The storage tank is connected to the suction of the boiler feed pumps. charge of the boiler feed pumps, a recirculation to line containing a At the disc or shutoff valve is connected.

Downstream from this connection is a check valve between the pump and the feed water supply header so that pressure from the supply header cannot return to the pump. With more than one pump connected, the check valve would be closed on any pump that is not in operation.

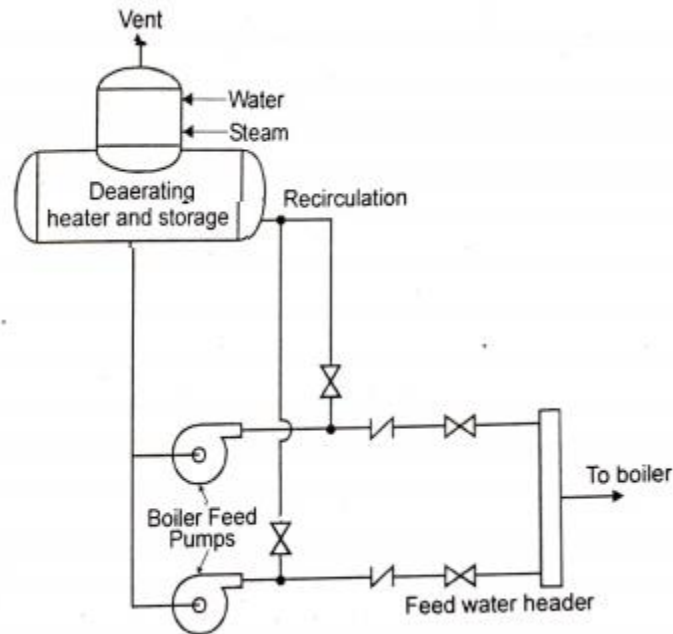

Boiler Feed water Pumping and Heating System

The recirculation line is open at low flows and is sized for approximately 15 to 20 percent of pump capacity. The necessity for this recirculation can be deduced from figure , which shows a typical set of characteristic curves for a constant speed boiler feed pump.

The power consumption is 60 to 70 percent of full load power at a 0 flow condition. With this condition of power input and no flow to dissipate the heat, the temperature would rise very rapidly and damage the pump.

To avoid this potential damage, approximately 15 to 20 percent of the water is recirculated to keep the pump from cavitating and overheating.

The entrained or dissolved gases are released from the water through his boiling and agitation) because the pressure in the heater is above atmospheric pressure, the gases can then be vented to atmosphere. Deaeration removes the oxygen and carbon dioxide as efficiently as mechanically possible. Scavenging chemicals are introduced to the boiler water to eliminate the remaining traces.

This process must be carried out with live steam direct from the boiler if exhaust steam is not available. Several additional feed water heaters in series are used with electric utility units. In these, the steam for heating the feed water between the condenser and the economizer is furnished by extracting steam from the turbine.

PERCENT OXYGEN TRIM CONTROL (OR) PERCENT OXYGEN AS AN INDIVIDUAL CONTROL INDEX

Percent the analyser and the analyser time constant. oxygen trim control is shown in figure. The function generator (a) develops a % oxygen set point signal as a function of boiler load Under the best conditions, all of these together will be at least 15 to 20 or other index of firing rate.

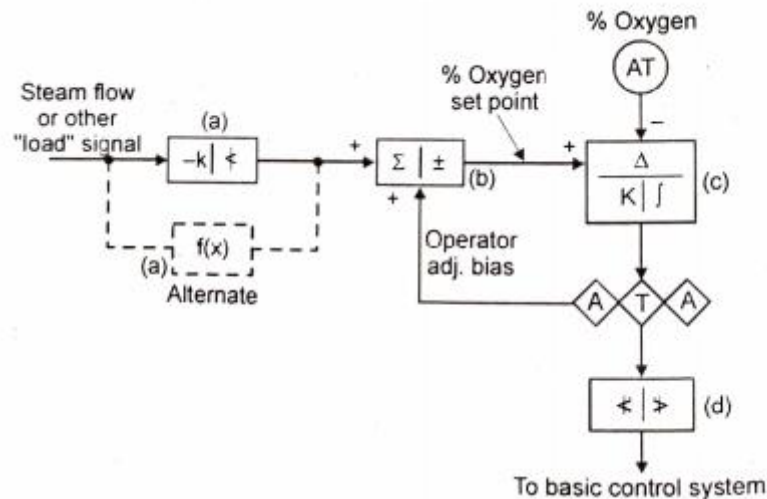

Percent Oxygen Trim Control Loop

The particular function generated should be based on boiler tests at way Steam by cascading the water-steam mixture over metal surfaces. In this or more boiler loads. The boiler operator has the ability, through the three manually generated set point bias signal and summer (b), to shift the % O₂ set point curve up or down without changing its shape. The controller (c) is tuned for a low gain and relatively slow integral e response in order to obtain control stability. The low gain results from the relationship between total air flow change and % oxygen change.

A change of 0.1% oxygen is equal to approximately 0.5% change in total air flow. If the analyser has a total range of 0 to 5% oxygen, then at 40% analyser span (2% O₂) the effect on air flow is 10% of total air flow or of air flow span. If the limiting air flow controller gain is 1.0, at a gain of one for the trimming action, the gain limit of the percent oxygen controller would be $[1 / (10/40)]$ or 0.25.

The slow integral tuning of the controller results from accumulated time constants in the control loop. These consist of controller and control tubing time constants, the time constant of the controlled device, the transport time from the control dampers and valves through the combustion process to Percent the analyser and the analyser time constant.

Under the best conditions, all of these together will be at least 15 to 20 or other index of firing rate. seconds and probably more. Of these, the transport time of the flue gases is % Oxygen an almost pure delay time constant, which varies as a function of boiler load.

Because of the greater potential for analyser failure as opposed to the generally used flow measurements, limits (d) are applied at the output of the trimming control. The limits can be applied as limits to the controller output or as a reduced gain at the point the trimming control enters the basic system.

If implemented by the "reduced gain" method, manual control has a broader signal range and the gain at the point of entry to the basic system becomes part of the overall loop gain. This allows an increased gain for the % O₂ controller. The function generation for most installations can be a two slope function generation as shown in figure. On those installations where such a simple method is not sufficient, a more complex function generation based on multiple slopes or a polynomial equation is necessary.

DISTRIBUTED CONTROL SYSTEM IN POWER PLANTS

Automation Structure for Power Plant Control

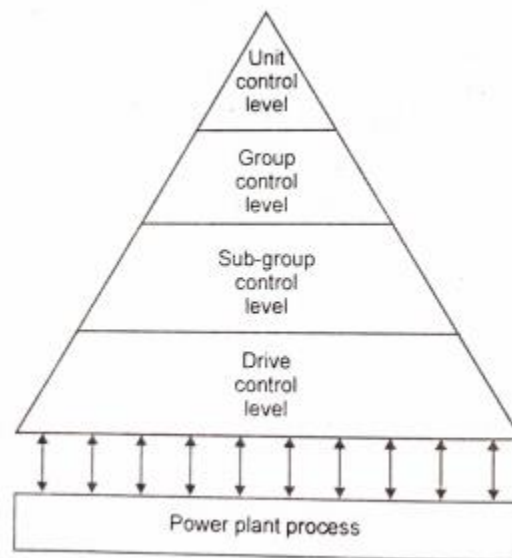

Hierarchical structure of DCS

- i. Hardware System
 - a. Field Stations
 - b. Sub-Group Control Stations
 - c. Group Control Stations

- d. Unit Level Control Stations
- e. Manual Control Stations
- f. Diagnostic Stations
- ii. Bus System
 - a. Group Bus
 - b. Plant Bus
 - c. Peripheral Bus
 - d. Back-up Bus
- iii. Software System
 - a. Data Acquisition and Alarming
 - b. Data Logging
 - iv. Human Interface
 - a. Alarm Display
 - b. Mimic Display
 - c. Trend Display
 - d. Bar Chart Display
 - e. Operator Guidance Messages
 - f. Multifformat Display
 - g. Plant Automation Messages
 - h. Voice Alarm Annunciation
 - v. System Reliability and Availability
 - a. Normal Operation
 - b. Group Controller Failure
 - c. Sub-Group Controller Failure
 - d. Unit Level Failure

Modern DCS For Power Plant Automation

Power generation comprises several major processes and each process can be further divided into sub-processes, corresponding to individual pieces of plant equipment. Thus, DCS architecture for power plant should match this process structure and provide for integrated monitoring, control, automation and protection using unified hardware and software system. It should encompass the functions such as boiler automatic control, level burner management, turbine control, sequential control and protection and interlock logics.

Also unit level automation and functions for plant monitoring, Supervision and maintenance should be included. The application of DCS should finally yield higher operating efficiency and availability of the power plant itself.

The automation structure, based on hierarchical plant process oriented control as shown in figure. The drive controller performs basic logic, driving and protection function of a single drive such as a pump, valve, or damper, whereas the sub-group controller performs modulating and binary control functions for a sub-process.

For example, a sub-group controller for a feed water sub-process controls all the feed pumps that comprise this sub-process. The sub-group control acts on a drive controllers. A unit master controller coordinates the total plant control and gives commands and instructions to the lower levels. The unit master controller essentially controls plant start-up and shut-down, and coordinates the plant processes during load variation. At the unit level, computers are used to collect all relevant power plant data, report alarms, and log data, to provide historical storage, performance calculation, plant operation scheduling, high level computer control functions, and man-machine functions. The entire system is interconnected by an hierarchical bus system.

Hierarchical automation structure in DCS

1. The unit coordination level handles higher level automation function, such as

- Unit coordination
- Unit operation
- Setpoint generation
- Load margin calculation
- Unit master control

2. At the group control level the higher level automation tasks associated with the plant functional areas are implemented, such as

Coordination programs (Example: boiler coordination program)

- Group controls
- Subgroup sequential controls
- Partial subgroup controls
- Setpoint controls (Example: Feedwater control)
- Plant protection

3. At the process interface level, process-related tasks are implemented. such as

Signal conditions (Analog, Binary)

Computing functions

Binary control of individual loops

Division of the automation structure in to these hierarchical levels. Documentation. results in a clear subdivision of the tasks of each level.

The tasks implemented at each level are designed in such a manner that their operation is not affected by failure of the automation functions at next higher level, although, naturally, the degree of automation is reduced as a result of the failure.

The man machine interface in an automation system provides the following facilities.

1. Process control functions for influencing and maintaining production:

Display of process variables for evaluation by the operator.

Operator control action and checkback display functions

2. Technical operational management functions for tasks related to economic production and rectification of faults:

information displays for plant monitoring (by the shift-in-charge)

documentation (production event recording and control system design documentation)

Optimisation

Maintenance

Components of the process control system

The components of the process control system provide all the functions required for process automation in power stations.

1. Acquisition and conditioning of process data.
2. Modulating and binary control.
3. Computing functions and optimisation.
4. Monitoring and alarm annunciation.
5. Control and monitoring of the process by the operator either by means of the Video Display Units (VDU) or by means of miniaturised control Modulating control of individual loops desk files.
6. Documentation.

Input/Output Modules

The functions of the process interface level are implemented on the Input/Output modules.

The following types of modules are available:

1. Signal modules for conditioning of process signals.
2. Configurable function modules for binary control of individual loops, modulating control and component protection.
3. Input/Output controller module for direct connection of Input/Output modules to the bus system.

Single or multi-function modules can be used depending on the level of fault-tolerance required for the installation.

Automation Systems

The central unit implements the higher-level automation tasks of unit Coordination and group control and monitors the Input / Output modules at the process interface.

In an improved version the central part consist of three independent, comment synchronous, central units (CU), the output signals of the three central units being logically combined in 2-out-of-3 voting systems.

An automation system card is available for tasks at the process interface level and is directly coupled to the LAN bus system. The fault tolerance can De increased by redundant provision of the Input / Output interface module and Input / Output modules.

Documentation and Configuration System

These systems implement the documentation, diagnostics maintenance tasks within the control system.

The configuration system is connected either directly to an automation system or via the LAN-bus is used for configuration of the automation system as well as of configurable Input / Output modules.

The workstation is used for drawing the function diagrams on the screen and subsequently generating the configuration code for the central unit and the configurable Input / Output modules of an automation system.

The workstation can be connected to the bus system for commissioning and maintenance of the function diagram level

This concept employs the "forward documentation" strategy and thus guarantees that the configuration code of the central unit and of the configurable Input / Output modules is absolutely identical to the logic content of the relevant function diagrams.

Operator Interface systems

The following operator interfaces can be employed in the process control system.

1. An operator interface employing miniaturised control desk files, which are hard wired to the binary and modulating control functions on the Input/Output modules of the process interface level.
2. An operator interface employing a hand-held terminal connected direct to a control of Input/Output module.
3. An operator interface employing operator communication module and monitoring system connected to the LAN-bus and thus to all automation systems which are connected to the bus. The operating systems (OS) can be configured either as single systems or in * redundant configuration with several monitors and process boards. The OS system also have direct access to the Input/Output modules via the bus, provided Input/Output interface modules have been installed..

The OS operator system provides facilities for operator control action in conjunction with displays on one or more VDU in the following formats:

1. Normalized operation displays for binary and modulating controls
2. Function diagram displays with indication of current status.
3. Graphic displays with indication current process data.

4. Trend and operating point displays.
5. Event message display.
6. Logs.

LAN-bus system

The local area network bus system is the central data communication component of the process control system. The bus system can also be designed in a redundant configuration to improve the fault-tolerance level of the system.

Data is transmitted serially over the bus system, which has a line configuration. A number of busses can be connected by bridges to form a network corresponding to the configuration of the complete plant.

The bus system does not employ a central controller or a PC can be connected to the bus; computers of other manufacture can also be connected to the bus via a suitable interface module.

Process Information system

These systems implement, the tasks of operational management as regards documentation, optimization, diagnosis of process sequences and maintenance of process components.

Application Concepts

The components of the process control system are suitable for a wide range of applications.

The flexibility of the system in its application in power stations is based on the following system features.

1. Configurable automation systems with graded capabilities.
2. Configurable Input/Output modules with functions of the process interface level and 2 bus interfaces for connection to the control room.
3. Operator communication and monitoring by means of hard miniaturised control desk files.
4. Operator communication and monitoring by means of bus connect. cause VDU based operator systems with power plant related information .
5. Short range serial data transmission by means of the cabinet bus and longer distance transmission by means of the local area network system.
6. Locally centralised or locally distributed structure as required.
7. Simple or redundant configuration to meet fault-tolerance requirements.

8. Automation unit, functionally superimposed on the individual control module.
9. Processing unit, performing combined individual control and automation functions.

INTERLOCKS IN BOILER OPERATTON

Interlocking is required to prevent operation of the control system. It is not appropriate to have the air flow control on automatic while the fuel flow is on manual.

Should the automatic control reduce the air flow to too low a value for the fuel being fired, a dangerous and potentially catastrophic situation would exist. A similar situation would exist if the fuels were on automatic and the air flow was on manual. Suppose the induced draft is being controlled by the furnace dratt and the controller is on manual while the forced draft is on automatic. An increase in the forced draft could cause excessive furnace pressure a danger condition. To avoid this possibility, a control system interlock system should be installed to prevent such operation.

Another aspect of the problem above is protection against the failure control system power supplies. For that reason, the system may in that compartment or one control device regulated by such controls could all controllers in that compartment to revert to manual control.

An example is to have all the fuel and air flow controls in one compartment, all of the steam temperature and reheat temperature controls in one compartment, and all of feed water controls in one compartment.

Protection against maintenance error while the process system is in operation and on automatic may also require interlock protection. A large electric utility control system is usually composed of a number of cabinets and many plug-in electronic cards that look alike.

In such systems it is possible to place part of the overall system on manual control for maintenance purposes. If this is done, it is also possible to inadvertently unplug a controller card that is furnishing control action for a part of the system that is still on automatic.

A suitable interlock can provide protection by having the system take security action if a card holding an automatic mode controller is withdrawn from its connector.

An example of an action could be for all controls in that compartment to revert to manual and hold their output signals.

Interlocks can also be designed in to the system to enforce a particular order of placing control loops on automatic or going from automatic to manual.

Typically, the first control subsystem to go on automatic is furnace draft Control since it is independent of other loops. Next is the feed water control, Which can be placed on automatic as soon as reliable signals of drum level, steam flow, and water flow are obtained.

It is in this condition, with feed water and furnace draft on automatic, That boiler testing is usually made. Only after the testing is completed and the rest of the control system is calibrated based on the test data should steam temperature control and fuel and air flow control be placed on automatic.

For an industrial boiler, the last control loop to be placed on automatic. The steam pressure control. For an electric utility boiler this accomplished by the boiler-turbine coordinated control or boiler following front end control. The last to be placed on automatic is the demand control.

The reverse of the order is described to be followed when transferring. Controls from automatic to manual. The control sequence above can be designed in to an interlock system that will inhibit any such operator action that is incorrect.

Classification of Interlocks

Two separate classifications involving trip interlock action should be made.

One relates to the "hazard" involved in the action. Such an action can occur through a healthy interlock circuit that is operating properly based on the inputs to the system. The action can also occur due to a failure or fault within the system. The hazard can be potential catastrophe damage to the operators, to the process equipment, to the process plant, and/or to the environment.

The second classification relates to the "interlock circuitry" and how its integrity is affected by faults within the system. The classification of the interlock system circuits provides a means of matching the reliability of a particular classification of interlock circuit to that of the degree of the particular hazard involved.

Interlock Circuitry

The classification of the interlock circuitry can be made relative to the action that occurs upon a single point failure or fault. This may be called the degree of redundancy or fault tolerance. The goal is keeping the protection in force at all times but recognizing that failures will occur.

The classifications described below are named on the basis of the number of unflawed interlock circuits necessary in order to retain interior protection.

1. 1-0-0-1 One out of One

A single circuit in which a single point failure in the system will cause Output action. The circuit itself should be designed so that any output.

2. 1-0-0-2 One out of Two ring this is called redundancy.

Two protective circuits are operating essentially in parallel. A single point failure will disable one of the two circuits while the redundant circuit continuous to provide the needed protection.

3. 2-0-0-2 Two out of Two

This is not redundancy because a single point failure in either circuit made will cause an output tripping action. This allows no fault tolerance yet has two circuits required to hold. Where 1-0-0-2 might be a parallel circuit (normal operation energized with reenergize to trip) One relates 2-0-0-2 would be a series circuit.

If 2 flame detectors are required to see flame or the boiler will trip, this is 2-0-0-2. This demonstrates that it is possible to have a 1-0-0-1 circuit with a 2-0-0-2 portion, a 1-0-0-2 circuit with a 2-0-0-2 portion, or a 2-0-0-3 circuit in which a critical portion is 2-0-0-2.

4. 2-0-0-3 Voting

This could be called triple redundancy. In this type of interlock system, the output of two out of three individual interlock circuits must agree to hold in a circuit in monitoring normal operation..

If two out of three agree to trip, tripping action will trip the process equipment device. Any single point failure involving the interlock devices will not trip the operating equipment. A maximum of two such failures will rip, just as a minimum of two good circuits will allow continued operation.

5. 2-0-0-3 Voting with Fault Tolerance

While this type of system requires two out or three voting to keep process equipment operating, more than two single point failures in seperate circuits can be tolerated.

For example, if the total circuit is made triple redundant and each ciro broken in to three sequential parts, 27 seperate potential pathways in 9 circuit segments exist.

Assume the three sequential parts are named "input, "processing ting and "output". Input 1 can connect to processing 2 and output 3. With 2-0-0-3 is each of the like parts, a single point failure in two out of three of such ii) Operation of forced draft without induced draft. An interlock should present this. a circuit part (e.g., "input") will cause the safety action to take place by tripping ng the piece of process equipment.

With the three sections of the circuit 2-0-0-3 voting in each like circuit on the failed fan immediately. part, a total of two, three or four single point failure possibilities, out of the total of 9 circuit sections, will cause tripping to occur.

One, the fuel immediately. two or three single point failures can occur and the equipment will continue to operate with full 2-0-0-3 interlock protection. This is shown in figure.

If any total circuit output 2-0-0-3 voting is used, up to five single point failures could occur and 2-0-0-3 voting on the outputs would be satisfied. A sixth single point failure would cause tripping to occur.

However, such an arrangement would be composed of the circuit of one "input" segment, one "processor" segment, and two "output" segments. This arrangement might satisfy the 2-0-0-3 output voting requirement but would lose its integrity since two thirds of the total-circuit would depend on 1-0-0-3.

It is usually not possible to achieve total redundancy that would be immune from a single point failure in the total system. Such situations might require three total flow measurement systems on the same flow, three primary elements and transducers, three sets of shutoff valves in series or three motor circuit breakers with associated input contacts, or three separate sources of electric power that didn't originate in the same place.

Alarms should advise the operator or maintenance personnel when a "non-tripping" fault occurs that would cause the interlock system to degrade, even though full safety protection continues to be maintained.

Boiler Hazards

Some of the more serious hazards related to boilers are as follows:

- i) Loss of flame in a single burner should shut down a burner. Loss of all flame should shut off all fuel immediately.
- ii) Operation of forced draft without induced draft. An interlock should prevent this.
- iii) Loss of a single forced or induced draft fan of a pair. An interlock should close the dampers circuit on the failed fan immediately.
- iv. Operating the boiler with the drum water level low enough to cause damage to the boiler. Such a water level should shut off the fuel immediately.
- v. Operating a balanced draft boiler with excessive pressure in the boiler furnace. While some pressure might be tolerated very temporarily, pressure above a set point level should immediately trip all fuel to the boiler.
- vi. Feedwater flow below a set point flow should immediately trip the fuel to a once through boiler.
- vii. Any reheat spray water should be shut off immediately if a turbine trips to avoid water damage to the turbine by back flow through the cold reheat steam line.

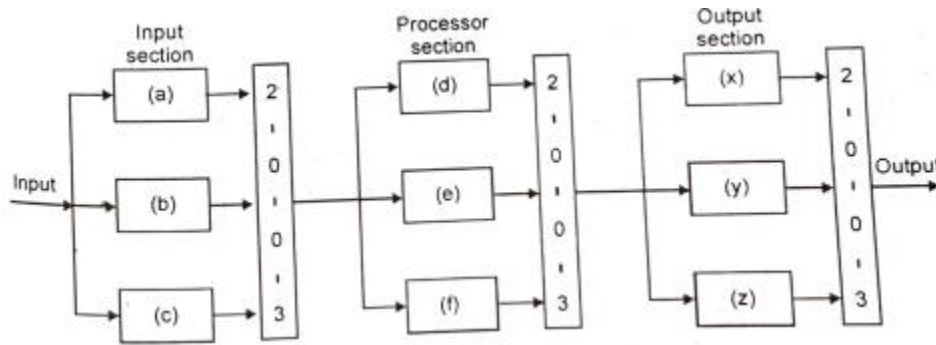

Interlock circuitry

FLUE GAS DEW POINT CONTROL

Flue gas dew point control used in cases where heat recovery equipment, such as an air preheater or an economizer, is applied to a boiler. In these cases, the flue gases are cooled to a lower temperature than with a simple boiler with no heat recovery. Both of these heat recovery devices can be represented by the diagram as shown in figure of a counter flow heat exchanger.

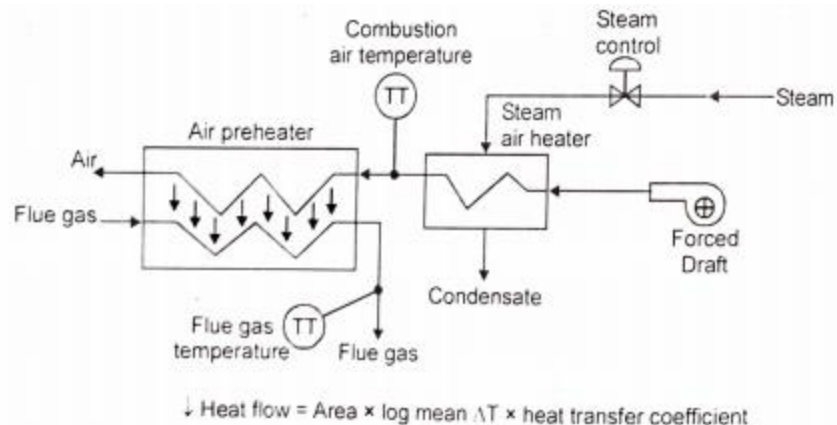

Dewpoint Control Process Arrangement

In the case of an economizer, the incoming fluid would normally be in excess of 220° F. In the case of an air preheater, the incoming combustion air might be less than 100° F. In order to avoid corrosion at the end of an air preheater, it is necessary to maintain the flue gas temperature above dew point temperature. The flue gas dew point temperature is determined by the moisture content of the flue gas and the presence and percentage SO₂ and SO₃ in the flue gas.

The addition of even small amounts of sulphur in the fuel, and thus SO₂ and SO₃ in the flue gas, causes a significant shift upward in the dew point and temperature. The resulting moisture would be a weak solution of sulphurous and sulfuric acid. At the "Cold end" of an air preheater, if the air temperature is 80°F and the flue gas temperature is 300° F, the average in

contact with the flue gas is considered to be 190°F, the average of the flue gas and combustion air temperature with a dew point temperature of 200°F, acid moisture would collect on the metal surface and corrosion would take place.

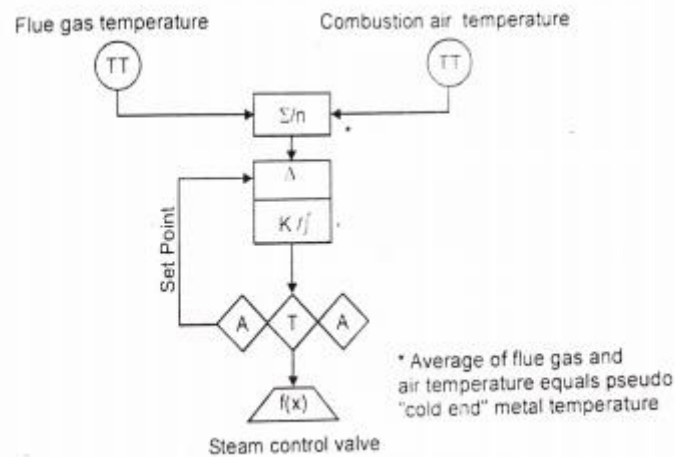

Flue Gas Dew Point Control

This can be avoided through use of a control method that raises the Incoming combustion air temperature so that the average cold end metal temperature is above the dew point. As the incoming air temperature is raised, temperature the flue gas temperature shifts upward a smaller amount. In the example above, raising the temperature of incoming air to 120°F would cause flue gas temperature to shift upward to approximately 340°F dew point temperature. If the dew point temperature were 230°F, the combustion air temperature would have to be raised still higher than the 120°F point. A control method that accomplishes this is shown in figure. An air heater, with steam as the heating medium, is placed in the combustion air stream ahead of the flue gas heat recovery air preheater. The steam is controlled to this heater in order to develop the desired combustion air temperature.

A simple feedback control loop as shown is usually adequate controlling the steam flow, The average of the flue gas and air temperatures shown as the feedback. is considered a pseudo metal surface temperature to provide a minimum flue gas temperature based on an assumption of the coldest expected inlet combustion air temperature.

The operation of this type of dew point control has a small impact on air flow and draft control by changing flow resistance on both the flue gas and air sides of the boiler. A 40°F rise in air preheater inlet air temperature will change the average specific volume across the air side of the air preheater and change its pressure drop by approximately 2.5 percent. The change in draft loss on the flue gas side will be a smaller percentage amount. This change will be only slightly noticeable even though open-loop air flow control is used.

Dew point: This is the saturation temperature of the mixture at the corresponding vapor pressure.

SOOT BLOWING

Soot buildup on the boiler tubes is a normal occurrence for liquid or solid fuel boilers. This soot accumulation can be reduced to some extent by maintaining the correct combustion conditions. In any event it must be removed periodically in order to avoid a severe loss in heat transfer.

Figure illustrate the loss in heat conductivity due to soot accumulation. Soot is an excellent insulator, as shown, and a thin layer can significantly reduce heat transfer. The effect is an increase in boiler draft The Air fuel ratio is the most common reference term used for mixtures in internal combustion engines. AFR = air In fuel loss and flue gas temperature with a resultant loss in boiler efficiency.

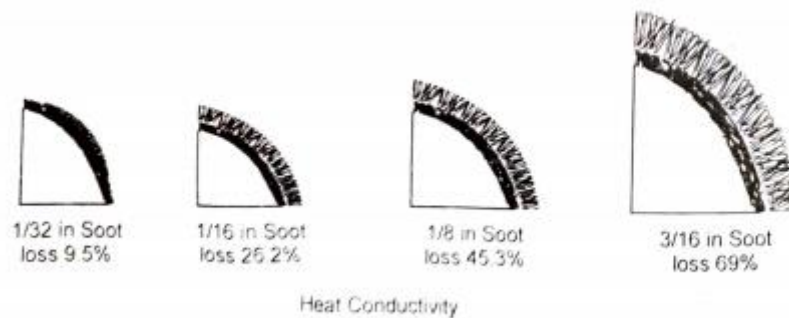

The Effect of Soot Building

Soot is normally removed from the tubes with devices called soot blowers. These are devices mounted along the sides of the boiler from which jets some of steam or compressed air are used to blast the soot from the tube. fuels have chemical characteristics that cause the soot to adhere . In these cases fuel additives are often used to change the characteristics of the soot in order that it may be more easily removed from the tubes.

The normal practice is to start the soot blowing at the furnace and sequentially blow soot in to the flue gas stream. Operation of soot blowers near the front of the boiler, in particular, may cause severe pulsations in the furnace draft. Por this reason, it may be desirable to reduce the set point of the furnace draft control and increase the level of combustion air flow during soot blowing periods.

UNIT – 5

Turbine -Monitoring and Control

TURBINE

A turbine may be defined in several ways. A few important definitions are given below:

1. The turbine is a prime mover in which gradual changes in the momentum of a fluid are utilized to produce rotation of the mobile member.
2. The turbine is a machine in which a rotary motion is obtained by the gradual change of momentum of fluid.
3. The turbine is a prime mover in which a rotary motion is obtained by centrifugal force brought in to action by changing the direction of a jet of a fluid escaping from a nozzle of high velocity.

CLASSIFICATION OF STEAM TURBINES

There are several ways in which the steam turbine may be classified.

1. With respect to the action of the steam
 - a) Impulse
 - b) Reaction
 - c) Combination of impulse and reaction
2. With respect to whether there is one or more revolving vane discs; separated by stationary reversing vanes.
 - a) Single stage
 - b) Multi stage
4. With respect to the direction of steam flow, as: steam leaving
 - a) Axial
 - b) Radial
 - c) Tangential
 - d) Mixed
 - e) Helical
 - f) Re-entry
5. With respect to the terminal pressure, as:

- a) Condensing
 - b) Non-condensing
6. With respect to the pressure of steam, as:
- a) High pressure
 - b) Medium pressure
 - c) Low pressure
7. With respect to the source of the steam, as:
- a) Extraction
 - b) Accumulator

Impulse Turbine

It is shown in figure. The bottom portion of the figure shows longitudinal section through the upper half of the turbine, the mid portion shows the development of the nozzles and blades and top the shows the variation in velocity of steam on its passage and also absolute pressure changes.

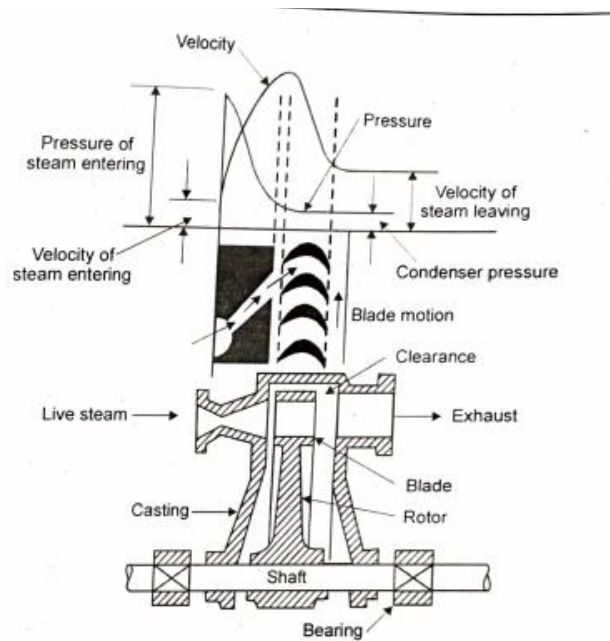

Impulse turbine

There is only one set of nozzles and complete expansion from the Steam chest pressure to the exhaust or the condenser pressure takes place in the one set of nozzles. Thus the pressure in the chamber is approximately equal to condenser pressure.

Due to very large ratio of expansion, the steam leaves the nozzle at very high velocity (Supersonic since the pressure ratio exceeds the Critical pressure ratio and the nozzle thus used is converging-diverging) of about 1000 m/sec.

The blade speed should be one-half of the steam speed for maximum Work done for good economy. Even though the rotor diameters are kept fairly small, the rotational speeds of the magnitude of 30,000 rpm may be obtained. Such high speeds can be used to drive the machines or generators only with a large reduction gearing arrangement.

Reaction Turbine

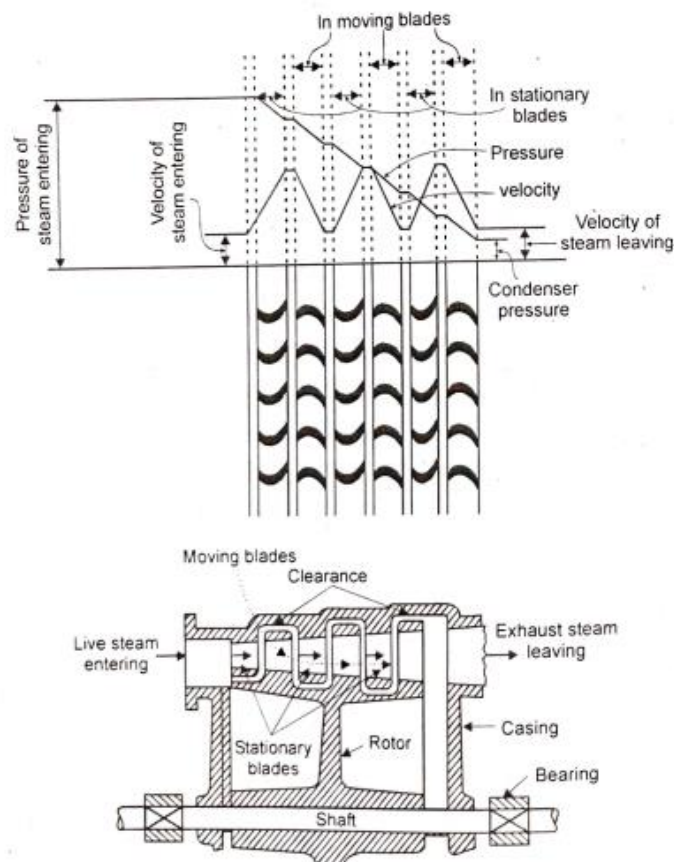

Reaction turbine

This type of turbine is shown in figure. There are number o rows of moving blades fixed to the shaft and equal number of fixed blades attached to the casing. The fixed blades in this arrangement correspond to the nozzle referred to in the impulse turbines.

Instead of a set of nozzles, steam is admitted for whole of the circumference and therefore, there is around admission. In passing through the first row of fixed blades, the steam undergoes a small drop in pressure and its velocity is increased.

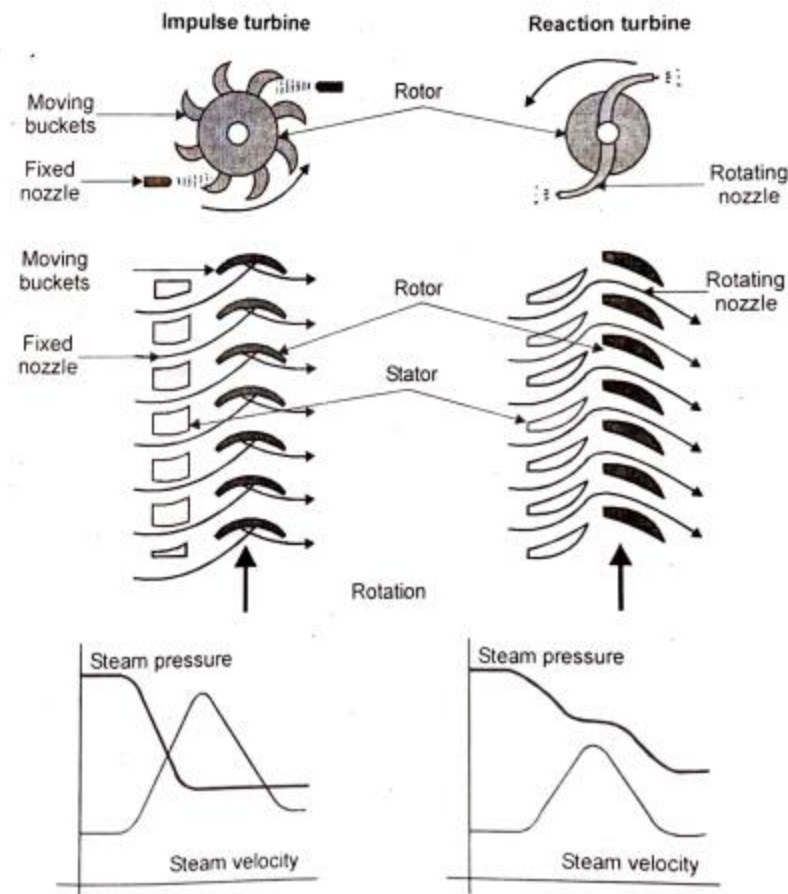

It then enters the first row of moving blades and just as in impulse turbine, it suffers a change in direction and therefore, momentum. This gives an impulse to the blades. A C But here the passage of the blades is so designed that there is also a small drop in pressure in the moving blades giving rise to increase in kinetic energy. This pressure drop gives rise to reaction in the direction opposite to that of added velocity. Thus the driving force is vector sum of impulse and reaction forces. The steam velocities in this type of turbine are comparatively low, the maximum being abrupt equal to blade velocity. Comparison between impulse and reaction turbines are shown in figure.

SHELL TEMPERATURE MONITORING AND CONTROL

The most important operational requirement is that excessive temperature differences within the steel casings of turbines especially at the inlet must be avoided during starting and shutting down.

In addition, accurate control to give a steady desired value of temperature at any instant will minimize thermal cycling, because excessive variations in temperature tend to cause high gradients in thick pipe-walls and casings.

The starting and shutting down process is therefore conditioned by the readings of thermocouples installed in the metal casings. Quick starting and loading will produce large gradients of temperature and if these are too large excessive thermal strains will be produced, which if repeated too often will ultimately lead to cracks in the turbine casing.

In a special quick-start test taken on a 120 MW machine with steam conditions of 1500 lb/in², 537°C and reheated to 537°C, use was made of high temperature strain gauges to calculate change in stress level at four positions on the h.p. inlet casing shown in figure.

Thermocouples were also fixed in various positions to enable stress to be calculated from temperature distribution using simplifying assumptions. The results of hot start test taken 6hr after shut-down are summarized in diagram from in figure.

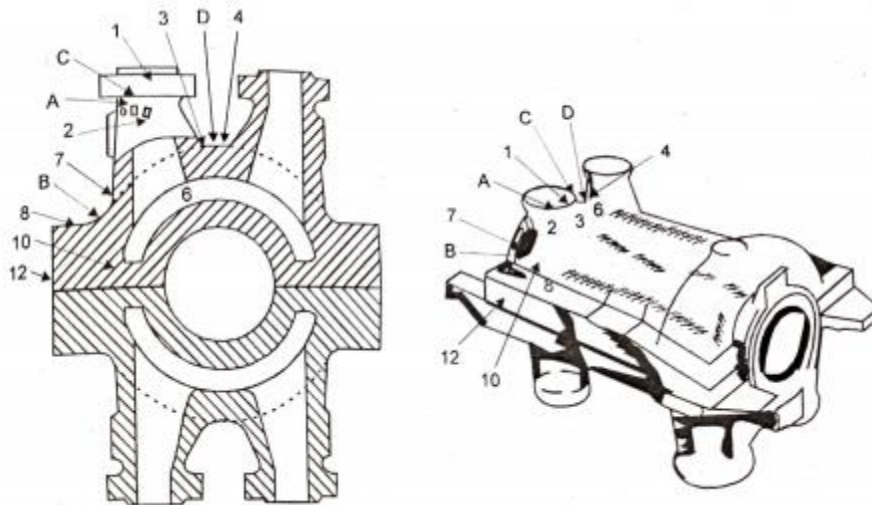

Position of strain gauges and thermo couples for high pressure cylinder

It will be observed that the machine was brought to full load within 1 hr, or a loading rate of 2 MW/min. The high stresses found at the casing near the inlet steam pipes have indicated that the heating rate of 225°C/h used for this hot start appears to be too high, and that a rate of 200°C would be safer.

The heating rate of the high-pressure inlet belt metal is usually taken as a guide to operators, and this can be one of the measurements fed into the automatic start-up controller. After a 36 h shut-down, a cold start test was taken, the heating rate being shown in figure as 133°C/h for a loading time of 2h, corresponding to a loading rate of 1 MW/min. The run-up and loading times for this test were shorter than the time normally used, as this was an investigation test; and heating rates below 100°C/h would be safer.

One important result was that, despite the small metal temperature differences shown in figure, strains in excess of yield strains were developed in the casing metal and it is therefore essential to ensure that tests are taken to assist in locating metal temperature thermocouples at places likely to be subjected to high stress during starting.

The reverse process, of cooling of the thermocouple placed in contact with the small metal in drilled the flanges during shut-down in combination with steam cooling by boiler gas damper adjustment, has been tried experimentally.

Recently, start-up trials have taken place using saturated steam through the turbine, while it is still on turning gear, in order to warm the casing generally to about 100°C before flange warming steam is applied, which accentuates the importance of avoiding heat loss during a short shut-down period.

Temperature Measurement

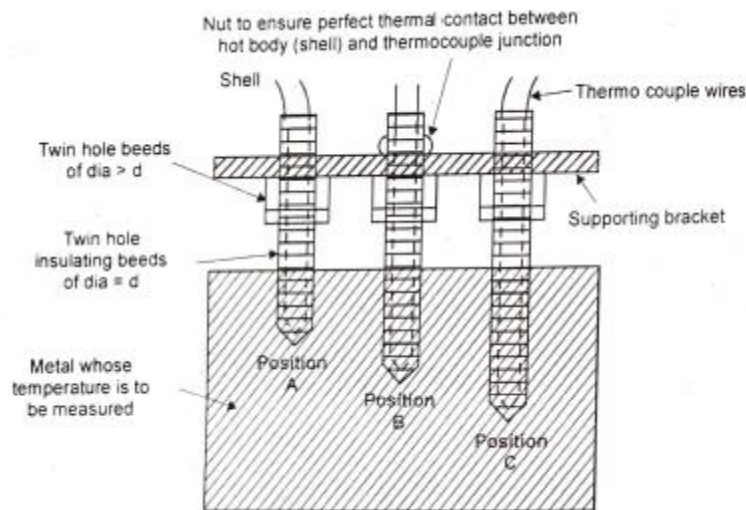

Shell temperature measurement

Thermocouples were used for this measurement of temperature D fixing in various positions to enable stresses to be calculated from temperature distribution using simplifying assumptions as shown figure.

here must be contact between the testing body and the bottom or hole in the hot plate where it is situated and insulating the thermocouple wires from the metal by the use of thin twin insulators or refractory or other material according to temperature and the junction. The reverse process, of cooling of the thermocouple placed in contact with the metal in drilled hole at the location where temperature is desired. There should be some mechanical arrangement to secure firm contact between the junction and the metal.

Monitoring Equipment

The platinum resistance temperature detectors with 100 Ohms resistance is now-a-days dominating the field and is considered to be a successful competitor for thermocouples. Circuitry has made substantial inroads in temperature measuring system.

In this transmitter, as shown in figure the emf generated by the thermocouple is converted into a DC current signal. The output signals obtained are fed to the receiving equipment for indication.

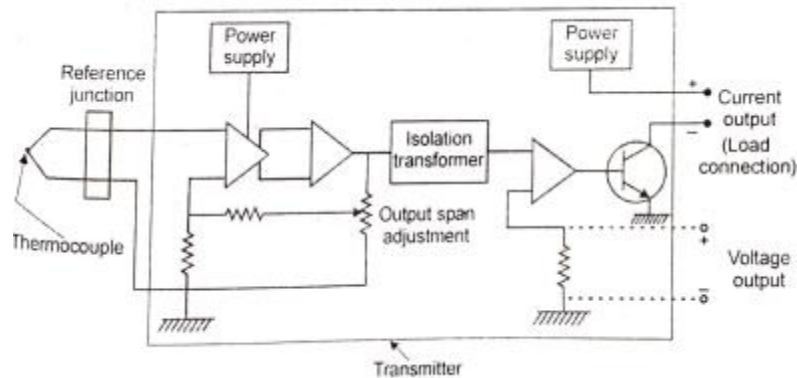

Temperature monitoring equipment

In the figure triangles represent amplifiers that build up input signal in stages. Input is electrically separated from output by an isolation transformer, permitting connection to any receiver without grounding techniques and operation with an input signal.

SPEED MONITORING AND CONTROL

Method of Governing Oil pump Relay piston the object of governing is to maintain the speed of a turbine sensibly constant irrespective of load. The performance will depend to a large extent, on the method used to regulate the steam supply to the turbine. The popular methods of governing are:

- i) Throttle governing
- ii) Nozzle control governing
- iii) By-pass governing

iv) Combination of 1 and 2

v) Combination of 1 and 3

Throttle Governing

It is shown in figure. In throttle governing, the steam pressure at which steam is admitted to the turbine is reduced at part loads.

The mechanism of throttle governing is simple but thermodynamically it is not efficient due to available heat drop getting reduced in the irreversible throttle process. Thus it is used on small turbines.

The steam flow to the turbine is throttled by balanced throttle valve actuated by a centrifugal governor. The effort of the governor may not be sufficient to move the valve against friction in bigger units. In the case an oil relay is incorporated and a small force produced by governor for a small change of speed is magnified to actuate the throttle valve.

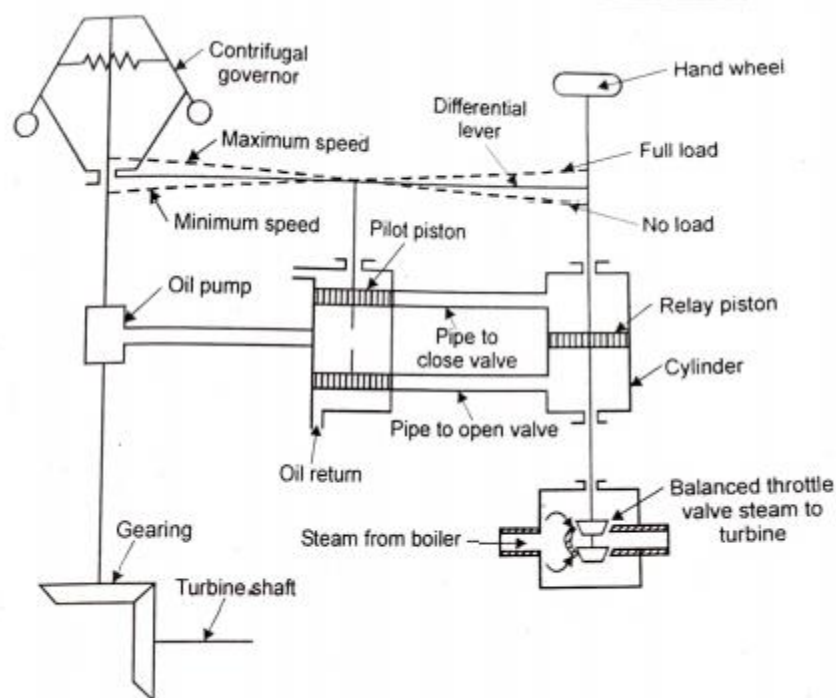

Throttle governing for speed control

A simple differential relay is shown in figure. The throttle valve is moved by a relay piston. A floating differential lever is fixed to its one end at some intermediate point on the floating differential lever, a piston valve is fixed.

The pilot piston valve consists of two piston valves covering ports without any overlap. The piston valves are also operated by lubricating Oil supplied by a returned to the oil drain

Operation

Let the turbine work at full rated load. The throttle valve will open to take care, of this load, at rated constant speed. reduced, the energy supplied to the turbine will be in excess and the If the load is turbine rotor will accelerate. Thus the governor sleeve will lift.

Once the throttle valve position is assumed same momentarily, the PLo valve spindle will get lifted opening the upper port to oil pressure and lower port to oil return.

The relay piston will thus close the throttle valve partially. The Lowering of throttle valve spindle will lower the pilot piston spindle and close the ports. As soon as the ports are closed, the relay piston gets stabilized in one position corresponding to the reduced load.

Nozzle Control Governing

In this method of control, the steam supplied to the different nozzle groups is controlled by uncovering as many steam passages as are necessary to meet the load by proper values. An arrangement often used for large steam power plants is shown in figure . The number of nozzles supplying the steam to the turbine are divided into groups as N_1 , N_2 and N_3 and the supply to these nozzles is controlled by the valves V_1 , V_2 and V_3 . The number of nozzle groups may vary from three to five or more.

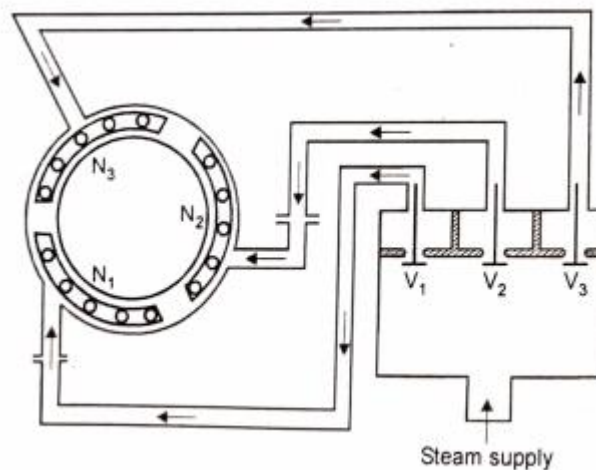

Nozzle control governing

Eccentricity Detectors

These detectors consist of a pair of electromagnets excited from a high frequency source. They are firmly fixed to a bearing pedestal or other part of the turbine frame so that the pole-pieces can be accurately located relative to the shaft or a special collar, as shown in figure.

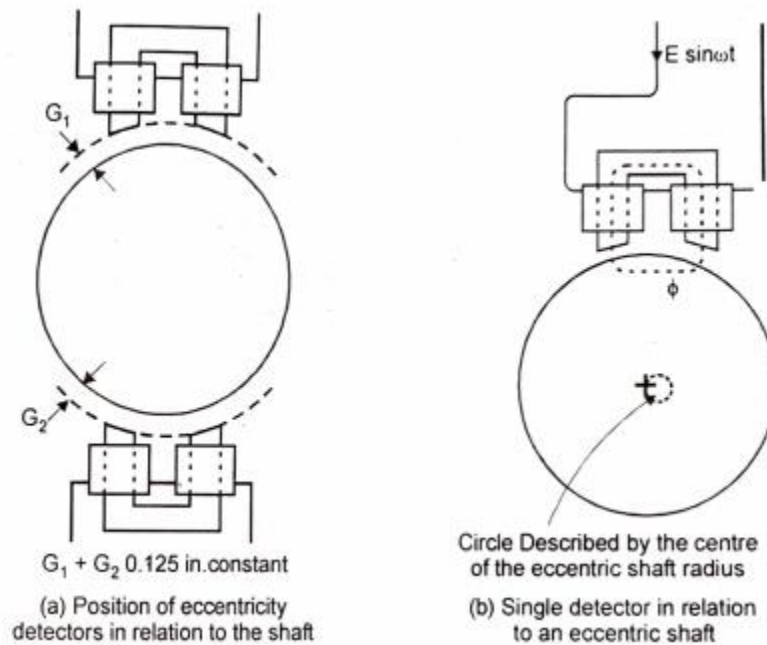

Eccentricity Detectors

Two types of detector are shown, one with electromagnets diametrically opposite and the other with one electromagnet. The variation in reluctance in the magnetic circuit causes modulation in the carrier wave as indicated at (b) of figure, this being the shape of the detector Current arriving at the bridge circuit of the instrument. Steam supply At point 'A' the rectified current is as shown at (c) and after a low pass filter which removes the high frequency components the wave shape as at (d) appears B. The signal is applied to the grid of a cathode follower valve, the output being taken from the cathode load resistances as a variable voltage representing the slow variation in the reluctance which can be measured at low speed while the set is on turning-gear.

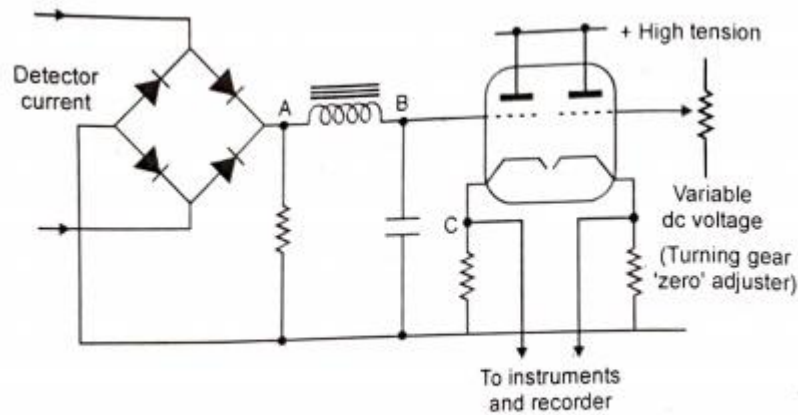

(a) Basic circuit diagram

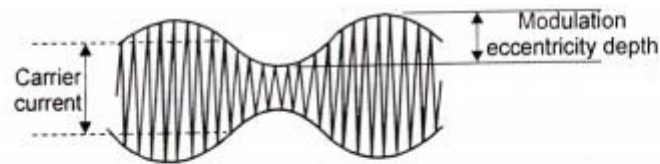

(b) Detector coil current



(c) Rectifier voltage at A



(d) Voltage at B



(e) Voltage at C

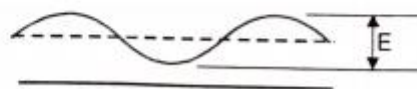

(f) Recorder current (d.c level dependent on 'displacement')

Shaft Eccentricity during turning gear operation

The grid voltage and cathode load can be adjusted to permit calibration of the indicated variation against measurement of eccentricity, a High tension which is valuable for detecting the presence of bent shafts with the rotors turning very slowly.

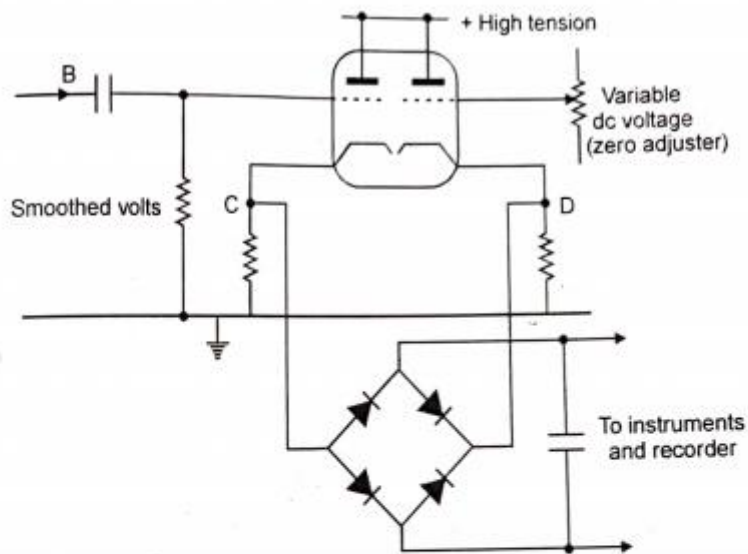

(a) Basic circuit diagram

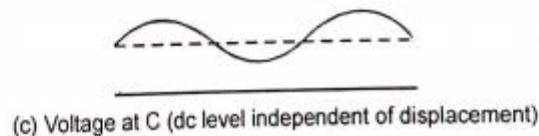
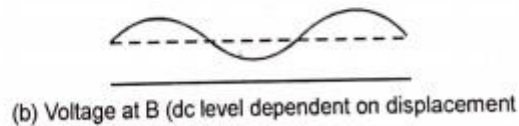

Shaft eccentricity during run-up to speed and at normal speed

When the set is being run up an automatic device switches the electrical output signal through a full-wave rectifier as in figure, so that a DC voltage will represent the mean eccentricity of the shaft revolving at the higher speeds during starting up and also a 3000 rev/min under normal operation.

Differential Expansion Detectors

The term differential expansion relates to the difference in expansion Between rotor and casing, and with machines having "back-off" gear; this will be the resultant of shaft displacement and measured differential Expansion. Two electromagnets placed on opposite sides of a collar on the shaft with their coils connected in series and shunted by a centre tapped resistor, are supplied from a high frequency source as shown in figure.

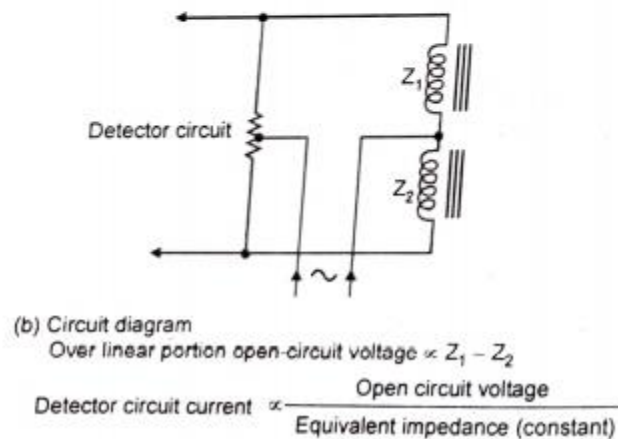
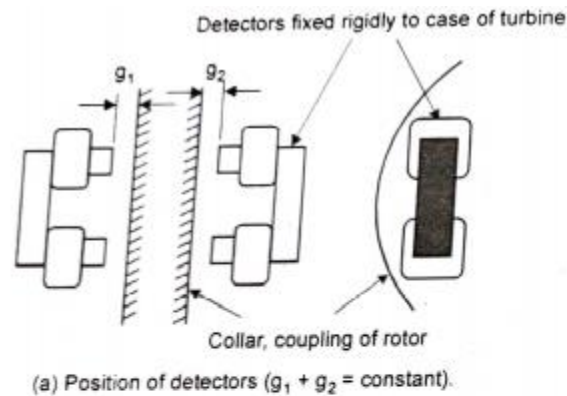

Differential expansion detector

These detectors are rigidly fixed to the turbine casing so of the causes a change in the reluctance of the move electromagnets which unbalances the electrical circuit, the resulting current being a measure of axial movement.

The detector current is set so that the datum differential is resented by a definite output from the bridge circuit. The arrangement represent is such that the rotor expansion relative to the casing causes an increase in bridge output whereas a rotor contraction would cause a decrease in output. These are sometimes known as positive and negative with respect Detectors fixed rigidly to case of turbine to the datum value.

Overall expansion is the axial movement of the turbine casing relative to the foundation of the bearing pedestal remote from the another point, the detector being either a solenoid with movable core linked to the pedestal or a potentiometer actuated by a similar link mechanism The movement of the arm causes an electrical current which represents the axial displacement of the pedestal.

Speed Measurement

Electrical measurement of speed is obtained by using a small AC generator driven from the turbo-generator shaft. This small generator is excited by a permanent magnet field so that its voltage is linear with speed. The voltage is usually rectified and applied to an indicating and a recording instrument.

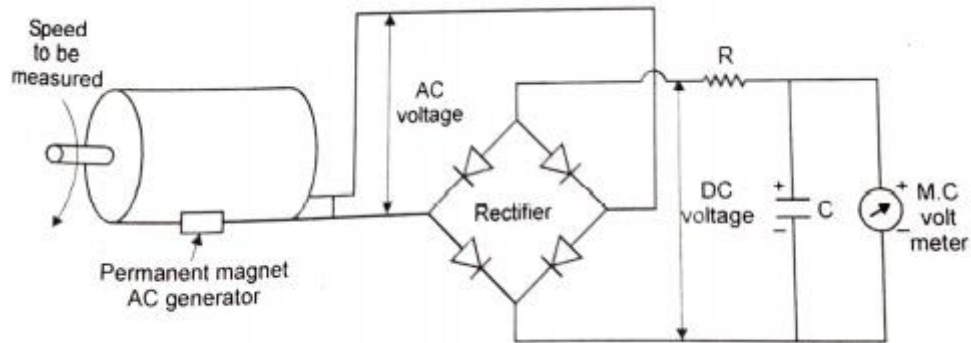

AC tachometer generator

The tachometer generator has rotating magnet which may be either a permanent magnet or an electromagnet. The coil is wound the stator and therefore the problems associated with commutate (as in DC tachometers) are absent.

he rotation of the magnet causes an emf to be induced in the stator coil. The amplitude and frequency of this emf are both proportional to the speed of rotation. Thus either amplitude or frequency of induced voltage may be used as a measure of rotational speed. The output voltage of AC tachometer generation is rectified and is measured with a permanent magnet moving Integrator coil instrument.

VIBRATION MONITORING AND CONTRL

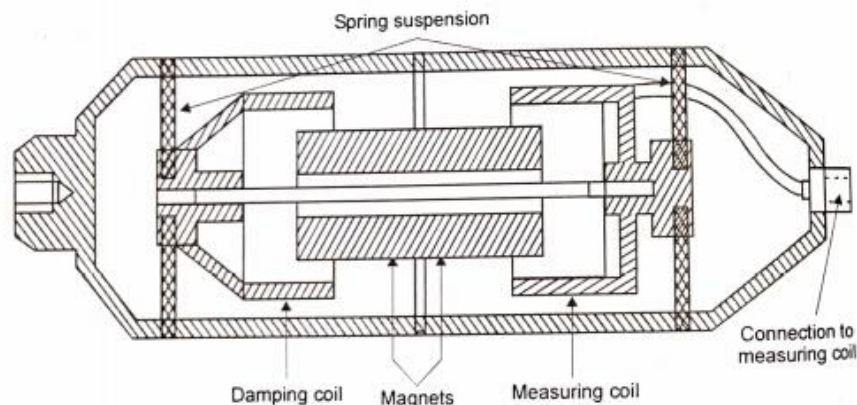

Electrical pickup for absolute vibrations

A cross sectional diagram of an electro-dynamic vibration pickup for the measurement of absolute rectilinear vibration is as shown in figure. In this system, the seismic mass comprises a pair of coils centered by two diaphragm springs within two magnet fields. The right hand coil is the measuring coil, in which voltage is developed electro dynamically, this being proportion" to the velocity. The other coil is a hollow copper cylinder " which eddy currents are induced which bring the damping the system up to $g = 1$. This pick up can also be employ the same manner as relative vibration pickup by connecting to the integrating and differentiating unit.

Monitoring Equipment

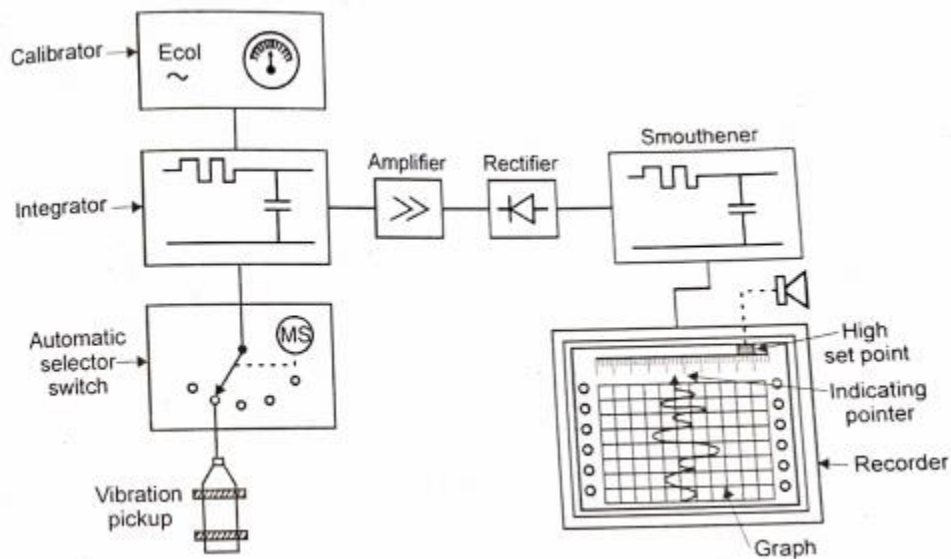

Block diagram of vibrating measuring equipment

As there are several bearings in the turbo-generator set and vibrations in all the three directions have to be monitored on each bearing, several pickups have to be employed. The vibration pickups used work on the electro-dynamics principle and are mounted on the bearing caps.

The electro-dynamics vibration pickup type of transducer is based on the movement of a coil within the field of a permanent magnet. The turns of the coil are perpendicular to the intersecting lines of force and movement of the coil induces a voltage which is at any moment proportional to the velocity of the coil. The various pickups are wired up to an automatic selector switch by heat resisting and screened cables so that the stray magnetic fields etc., do not influence the voltage carried by these wires.

The resulting DC voltage, which is a measure of the is finally measured and recorded on an automatic potentiometer record vibration level, meter recorder, the scale of which is calibrated in microns amplitude. With the aid of an automatic selector switch MS, upto 12 pickups can be connected for sequential recording. The recorder is also provided with control amplifiers driving a relay which can be employed for alarm purposes.

LUBRICATION SYSTEM FOR STEAM TURBINES

Lubrication is needed to minimize friction in main bearings, thrust bearings and reduction gears as well as it helps to cool the journals and bearing surfaces. Proper lubrication is of utmost importance in the operation of turbine. High journal speed, heat conducted from the steam to the bearings and the possibility of water leaking in to the oil are some of the problems that make lubrication difficult. The oil for lubrication should be continuous, under pressure, cool and free from injurious foreign matter. A lubrication system used for a high capacity turbine (200 MW) is shown in figure. The system consists of main centrifugal type of pump as shown in figure which is directly fitted on H.P turbine shaft and two more driven centrifugal type auxiliary oil pumps (P₁ and P₂). The oil to the main centrifugal pump is supplied through the jet pumps (J₁) which maintain positive pressure at the suction of main pump. The auxiliary pump (P₁) is fully rated, AC motor driven which is used only during starting, shutting down and in emergencies. It automatically comes in action when the oil pressure in the main relay system falls below a predetermined value.

POWER PLANT INSTRUMENTATION TURBINE- MONITORING AND CONTROLLING

NECESSITY OF COOLING THE CONDENSER WATER

The cooling water system is one of the most important systems of power plant and its availability predominantly decides the plant site, The high cost of water makes it necessary to use cooling towers for The temperature of the discharged water should be kept within safe limits to prevent harm to fishes. The limit of discharged water temperature is specified by the Fisheries Board. The arrangement of the open system is shown in figure. Water cooled condensers. Steam from prime mover As the cooling water takes the latent heat of steam in the condenser, the temperature of the water increases. The hot water coming out of the condenser cannot be used again in a closed system without pre cooling. This is because, the hot water coming out if used again will not be able to absorb the heat reaches near saturation temperature of steam at Condenser condenser pressure and the condenser vacuum cannot be maintained. Therefore it is absolutely necessary to pre cool the water coming out of Pump condenser before using again.

Classification of Cooling Systems Screen

The cooling systems which are commonly used in practice according to the availability of the water are listed below. Cold water in River Hot water out Cooling System Mixed System Open or Once through system Closed System Figure Open or Once through system The position of inlet and outlet should be chosen in such a way that there should not be recirculation of hot water which impairs the efficiency of the condensing plant. Water Cooling Air Cooling Ponds Such recirculation is possible in small rivers and canals therefore Direct dry type Towers Cooling Tower System Indirect air the distance between the inlet and discharged points should be as large as one kilometre or more. This type of cooling system can be used only where required quantity of water is available throughout the year. Cooling System 5.7.1.1 Open or Once Through or River

Water System In this system, the water is drawn directly from the upstream side of the river, pumped through the condenser and then discharged to the downward side of the river.

NECESSITY OF COOLING THE CONDENSER WATER

The cooling water system is one of the most important systems of power plant and its availability predominantly decides the plant site. The high cost of water makes it necessary to use cooling towers for water cooled condensers. Steam from prime mover As the cooling water takes the latent heat of steam in the condenser, the temperature of the water increases. The hot water coming out of the condenser cannot be used again in a closed system without precooling. This is because, the hot water coming out if used again will not be able to absorb the heat reaches near saturation temperature of steam at Condenser condenser pressure and the condenser vacuum cannot be maintained. Therefore it is absolutely necessary to pre cool the water coming out of Pump condenser before using again.

Classification of Cooling Systems Screen

The cooling systems which are commonly used in practice according to the availability of the water are listed below.

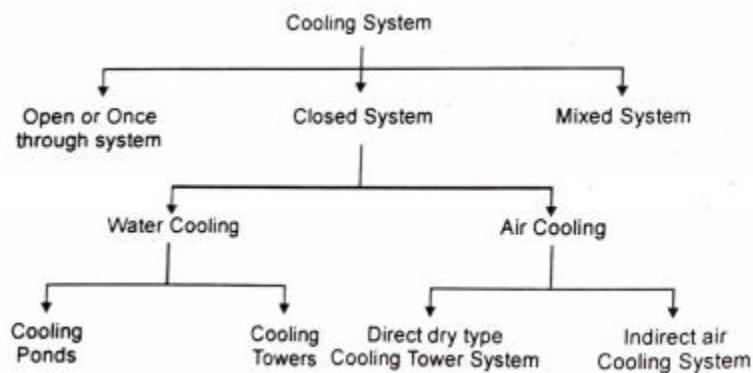

Open or Once Through or River Water System

In this system, the water is drawn directly from the upstream side of the river, pumped through the condenser and then discharged to the downward side of the river at temperature 5 to 10°C in excess of the inlet temperature.

The temperature of the discharged water should be kept within safe limits to prevent harm to fishes. The limit of discharged water temperature is specified by the Fisheries Board. The arrangement of the open system is shown in figure.

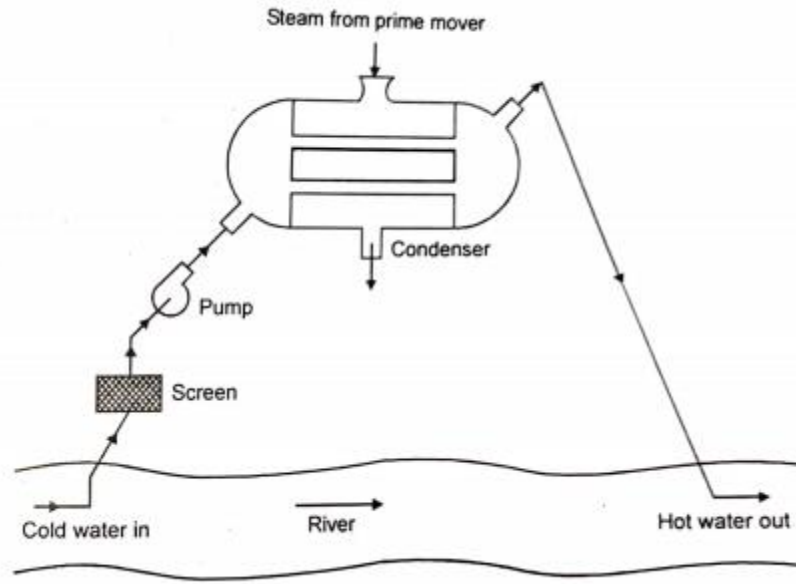

Open or Once through system

The position of inlet and outlet should be chosen in such a way that there should not be recirculation of hot water which impairs the efficiency of the condensing plant.

Such re-circulation is possible in small rivers and canals therefore indirect air the distance between the inlet and discharged points should be as large as one kilometre or more. This type of cooling system can be used only where required quantity of water is available throughout the year.

Closed System

When enough quantity of water is not available for cooling requirement from river, then closed type system is universally adopted.

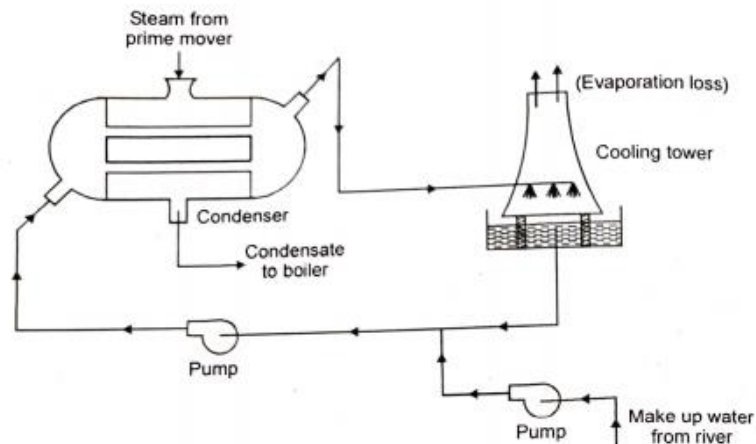

Closed system

In closed system, the hot water coming out of condenser is cooled by direct contact condenser either by spraying in the pond or passing through the cooling tower instead of discharging to the downward side of the river.

The quantity of water required is collected from the river during turbine flood period or when sufficient water is available with required purity. Motor Pump and same water is used again and again for condenser by passing through the cooling towers. Such arrangement of cooling system is shown in figure .

With this system of cooling also, an external source of water is needed to replace tower evaporation and carry over losses. The quantity of water lost by evaporation and carry-over varies between 2 to 5% of that circulated depending upon the design of tower.

Air-Cooled or Dry-Type Cooling System

The dry cooling system (air-cooling), offers a solution to the problem of thermal pollution of water. The dry cooling system rejects the heat directly to the atmosphere which is the largest heat sink .

Two different dry-type cooling systems which are commonly used are

- i) Indirect dry types or Heller cooling system
- ii) Direct dry type cooling system

Indirect Dry Type Cooling System

The principle components of this system are shown in figure. The condensate collected in the condenser is partly fed to the boiler and partly passed through the cooling coils.

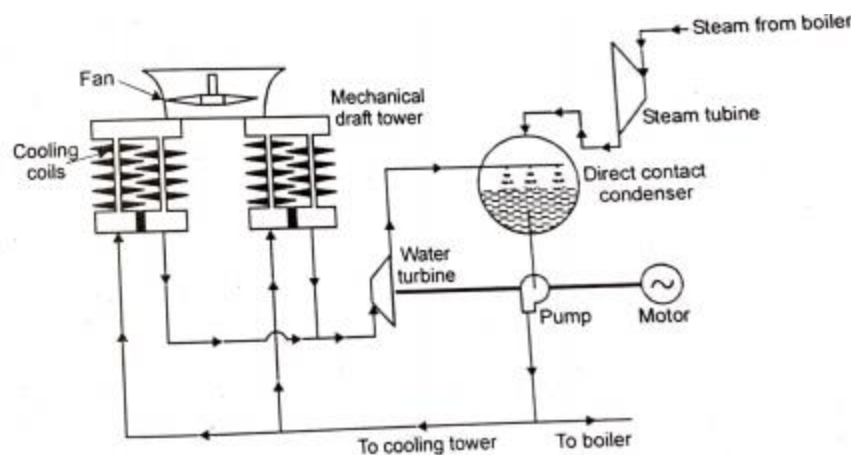

Indirect dry type cooling system

The hot condensate passed through the cooling coils is cooled by passing the air with the help of fan. The cooled water coming out of cooling coil is spread through the nozzle into the condenser. The steam coming out of turbine in condensed coming in direct contact with water spread through the nozzle.

ne water turbine included in the circuit is to recover some of the Pressure and elevation head between the cooling coils and condenser.

As the circulating water does not come into direct contact with ne cooling air, therefore, there is no evaporative loss or water as in the wet type cooling tower.

This system of cooling is always referred to as Heller system as this concept of indirect system of condensation by air was first presented by Lazlo Heller

Direct Dry Type Cooling System

The condensation of steam coming out of turbine is effected with the use of atmospheric air instead of water as in case of once through cooling system.

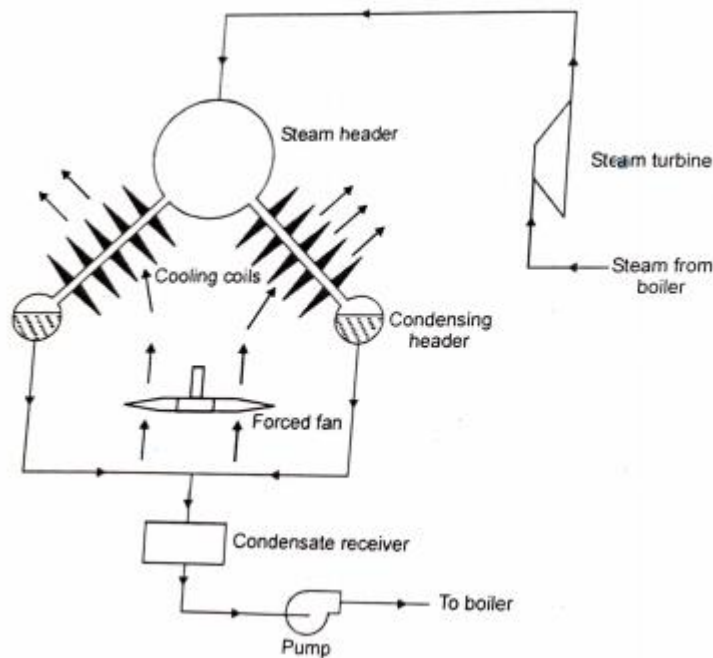

Direct dry type cooling system

STEAM PRESSURE OR STEAM FLOW CONTROL

For the simpler systems, a simple proportional or proportional plus integral feedback controller may be used for steam pressure control. Forced fan Figure demonstrates this method for regulating the firing rate using steam pressure. In some installations, a constant steam flow may be required for one or more boiler in combination, while other boilers connected to the same

header are used for controlling steam pressure. Condensate receiver It is also possible to arrange the system as shown in figure. So that the control for a particular boiler can be switched between steam pressure and steam flow control. The switching procedure would require the boiler operator to switch the control to manual, adjust the set point.

NON CONTACT TYPE SPEED MEASUREMENT METHODS

- 1) Using Photo Electric Tachometer
- 2) Toothed Rotor Tachometer Generator
- 3) Stroboscopic Method
- 4) Eccentricity Detectors

Photoelectric Tachometer

This method of measuring speed of rotation consists of mounting an opaque disc on the rotating shaft as is shown in Fig. 5.28.

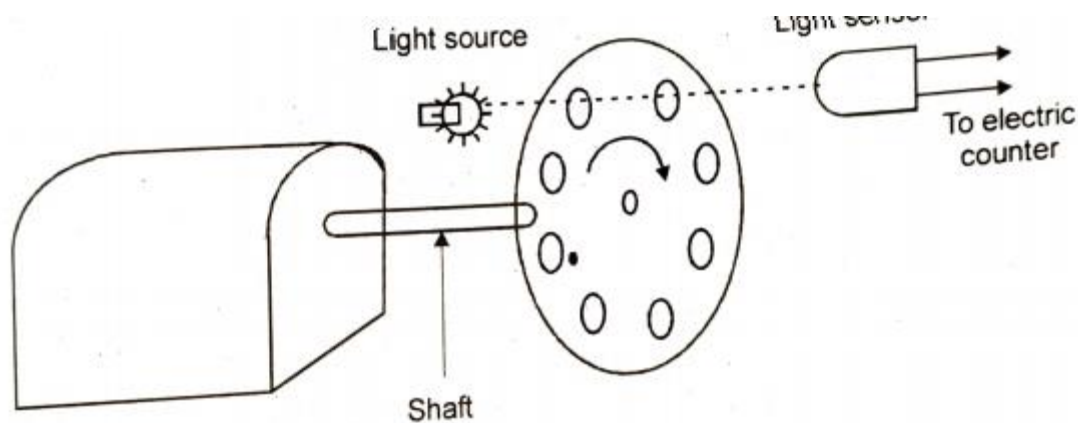

Photoelectric Tachometer

The disc has a number of equidistant holes on its periphery. At one side of the disc a light source is fixed and at the other side of the disc, and on line with the light source, a light sensor such as a photo tube or some photosensitive semi-conducting device is placed. When the opaque portion of the disc is between the light source and the light sensor, the latter is unilluminated and produces no output. But when a hole appears between the two, the light falling upon the sensor produces an output pulse. The frequency at which these pulses are produced depends upon the number of holes in the disc and its speed of rotation. Since the number of holes is fixed, the pulse rate is a function of speed of rotation. The pulse rate can be measured by an electronic counter which can be directly calibrated in terms of speed in rpm.

Advantages

This system has two distinct advantages: pick up

- i) The output format is digital and this means that if the tachometer is a part of a digital instrumentation system, no analog to digital conversion is necessary.
- ii) The pulse amplitudes are constant. This simplifies the electronic circuitry.

Disadvantages

- i) A disadvantage is that the light source must be replaced from time to time. A typical life time for light source is 50,000 hours.
- ii) The accuracy of this method depends principally on the error Toothed rotor represented by on pulse. The digital meters measure frequency by counting the number of input pulses which occur in short period of time called gating period. If this period is too small serious errors Since the number of teeth is known, the speed of rotation can be may be caused. The gating period should therefore, be chosen to give a sufficiently large count. In general, all the digits on the digital display should be utilized.

The factors which the user can control to minimize the errors are:

- i) Gating period, and
- ii) Number of pulses generated per revolution.

Toothed Rotor Tachometer Generator

This tachometer generator consists of a metallic toothed rotor mounted on the shaft whose speed is to be measured. This is shown in Fig. A magnetic pickup is placed near the toothed rotor.

The magnetic pickup consists of a housing containing a small permanent magnet with a coil wound round it. when the rotor rotates, the reluctance Or the air gap between pickup and the toothed rotor changes giving rise to a induced e.m.f in the pickup coil. This output is in the form of pulses, with a variety of wave shapes.

The frequency of the pulses of induced voltage will depend upon number of teeth of the rotor and its speed of rotation.

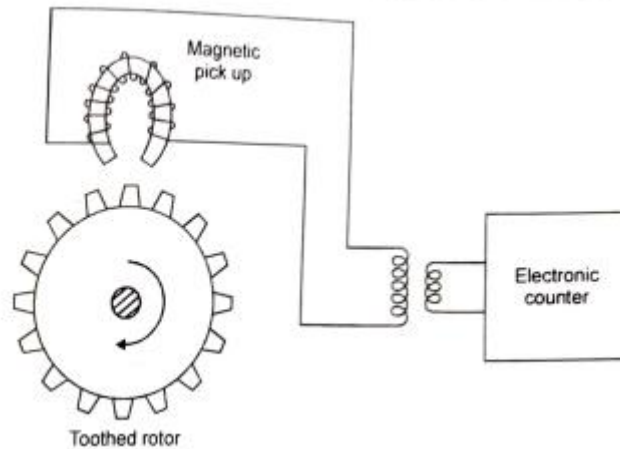

Toothed Rotor Tachometer generator

Since the number of teeth is known, the speed of rotation can be determined by measuring the frequency of pulses with an electronic counter. Suppose the rotor has T teeth, the speed of rotation is n rps and number of pulses per second is P .

Number of pulses per revolution = T .

$$\begin{aligned} \text{Hence speed } n &= \frac{\text{pulses per second}}{\text{number of teeth}} \\ &= \frac{P}{T} \text{ rps} = \frac{P}{T} \times 60 \text{ rpm} \end{aligned}$$

A typical rotor has 60 teeth. Thus if the counter counts the pulses in one second, the counter will directly display the speed in rpm.

We have mentioned above that the pulses have a variety of wave shapes. This is immaterial, as this tachometer is always connected to an electronic Counter, whose requirement is merely that the amplitude be great enough to trigger a count.

Variable reluctance tachometer probably is the most common type of tachometer in use today.

Advantages

The advantages of this tachometer are

- i) It is simple and rugged in construction
- ii) It is maintenance free

iii) It is easy to calibrate. This has been illustrated earlier, if the rotor has 60 teeth and the pulses are counted by counter in one second, the count displayed by the counter gives the speed directly in r.p.m. Gas tube iv) The information from this device can be easily transmitted.

Stroboscopic Method

The stroboscope is a simple, portable manually operated device which may be used for measurement of periodic or rotary motions. Basically, the instrument is a source of variable frequency flashing brilliant light, the flashing frequency being set by the operator. The circuit used is based upon variable frequency oscillator which controls the flashing frequency. The speed is measured by adjusting the frequency so that the moving objects are visible only at specific intervals of time.

The method of use of the stroboscope depends upon imperfect dynamic Shaft Speed Measurements response of the human eye. If a strong light is caused to flash on a moving object which, at the time each flash occurs, occupies a given position, the object will appear to be stationary. Therefore the method is useful for only those types of motions which occur regularly after a fixed interval of time, such as oscillation or rotation. The stroboscope consists of a source of flashing light whose frequency can be varied and controlled. This source is called a strobotron.

Strobotron

It is hot cathode gaseous discharge tube as shown in Fig 5.30. It has a cathode, an anode and two grids, one is called the inner grid and other as the outer grid.

If the potential of the outer grid is increased or that of inner grid decreased beyond a certain limit, the conduction starts. Once the conduction starts, it can be stopped only by removing the anode potential.

The flashing of light is started by a signal from an oscillator vibrator. When the tube is ionized and starts giving out flashes the Advantages Capacitor C is discharged and a heavy current drawn by it reduces the due to large voltage drop in resistance R. The ionization stops and so does the of light. In the mean time the capacitor is recharged and waits for the next pulse to start the flashing again.

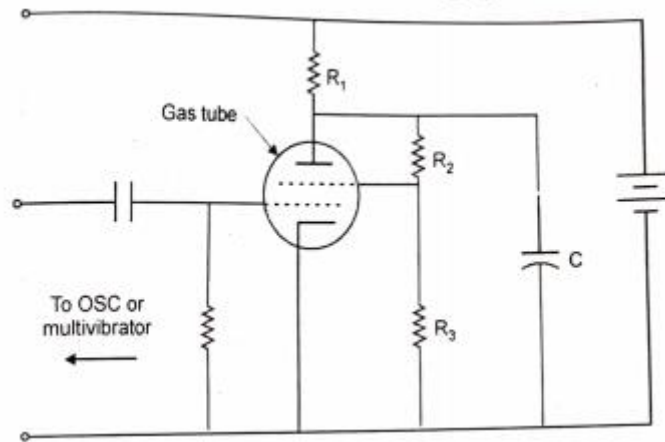

Shaft Speed Measurements

A distinctive mark is made on the shaft or on a disc attached to the shaft as shown in Fig 5.31. A stroboscope is made to flash light directly on the mark. The flashing frequency is adjusted until the mark appears stationary. Under these conditions, the speed is equal to the flashing frequency provided that the approximate speed of the shaft is known in advance and the flashing frequency is not allowed to depart too much away from this value. The scale of the stroboscope is calibrated in terms of speed which can be directly read off. If the two conditions outlined above are not met or if there are several identical marks on the shaft like spokes of a wheel or jaws of a chuck, serious errors in the measurement may arise.

MULTIPLE CHOICE QUESTIONS WITH ANSWER**1. The commercial sources of energy are**

- (a) solar, wind and biomass
- (b) fossil fuels, hydropower and nuclear energy
- (c) wood, animal wastes and agriculture wastes
- (d) none of the above

Ans: b

2. Compounding of steam turbine is done for

- (a) reducing the work done
- (b) increasing the rotor speed
- (c) reducing the rotor speed
- (d) balancing the turbine

Ans: c

3. In India largest thermal power station is located at

- (a) Kota
- (b) Sarni
- (c) Chandrapur
- (d) Neyveli

Ans: c

4. The percentage O₂ by Weight in atmospheric air is

- (a) 18%
- (b) 23%
- (c) 77%
- (d) 79%

Ans: b

5. The percentage O₂ by volume in atmosphere air is

- (a) 21%
- (b) 23%
- (c) 77%
- (d) 79%

Ans: a

6. The proper indication of incomplete combustion is

- (a) high CO content in flue gases at exit
- (b) high CO₂ content in flue gases at exit

- (c) high temperature of flue gases
- (d) the smoking exhaust from chimney

Ans: a

7. The main source of production of biogas is

- (a) human waste
- (b) wet cow dung
- (c) wet livestock waste
- (d) all above

Ans: d

8. India's first nuclear power plant was installed at

- (a) Tarapore
- (b) Kota
- (c) Kalpakkam
- (d) none of the above

Ans: a

9. In fuel cell, the _____ energy is converted into electrical energy.

- (a) mechanical
- (b) chemical
- (c) heat
- (d) sound

Ans: b

10. Solar thermal power generation can be achieved by

- (a) using focusing collector or heliostates
- (b) using flat plate collectors
- (c) using a solar pond
- (d) any of the above system

Ans: d

11. The energy radiated by sun on a bright sunny day is approximately

- (a) 700 W/m²
- (b) 800 W/m²
- (c) 1 kW/m²
- (d) 2 kW/m²

Ans: c

12. Thorium Breeder Reactors are most suitable for India because

- (a) these develop more power
- (b) its technology is simple
- (c) abundance of thorium deposits are available in India
- (d) these can be easily designed

Ans: c

13. The overall efficiency of thermal power plant is equal to

- (a) Rankine cycle efficiency
- (b) Carnot cycle efficiency
- (c) Regenerative cycle efficiency
- (d) Boiler efficiency x turbine efficiency x generator efficiency

Ans: c

14. Rankine cycle efficiency of a good steam power plant may be in the range of

- (a) 15 to 20 percent
- (b) 35 to 45 percent
- (c) 70 to 80 percent
- (d) 90 to 95 percent

Ans: b

15. Rankine cycle operating on low pressure limit of p_1 and high pressure limit of p_2

- (a) has higher the thermal efficiency than the Carnot cycle operating between same pressure limits
- (b) has lower the thermal efficiency than Carnot cycle operating between same pressure limit?
- (c) has same thermal efficiency as Carnot cycle operating between same pressure limits
- (d) may be more or less depending upon the magnitude of p_1 and p_2

Ans: a

16. Rankine efficiency of a steam power plant

- (a) improves in summer as compared to that in winter
- (b) improves in winter as compared to that in summer
- (c) is unaffected by climatic conditions
- (d) none of the above

Ans: b

17. Carnot cycle comprises of

- (a) two isentropic processes and two constant volume processes
- (b) two isentropic processes and two constant pressure processes
- (c) two isothermal processes and three constant pressure processes
- (d) none of the above

Ans: b

18. In Rankine cycle the work output from the turbine is given by

- (a) change of internal energy between inlet and outlet
- (b) change of enthalpy between inlet and outlet
- (c) change of entropy between inlet and outlet
- (d) change of temperature between inlet and outlet

Ans: b

19. Regenerative cycle thermal efficiency

- (a) is always greater than simple Rankine thermal efficiency
- (b) is greater than simple Rankine cycle thermal efficiency only when steam is bled at particular pressure
- (c) is same as simple Rankine cycle thermal efficiency
- (d) is always less than simple Rankine cycle thermal efficiency

Ans: a

20. In a regenerative feed heating cycle, the optimum value of the fraction of steam extracted for feed heating

- (a) decreases with increase in Rankine cycle efficiency
- (b) increases with increase in Rankine cycle efficiency
- (c) is unaffected by increase in Rankine cycle efficiency
- (d) none of the above

Ans: b

21. In a regenerative feed heating cycle, the greatest economy is affected

- (a) when steam is extracted from only one suitable point of steam turbine
- (b) when steam is extracted from several places in different stages of steam turbine
- (c) when steam is extracted only from the last stage of steam turbine
- (d) when steam is extracted only from the first stage of steam turbine

Ans: b

22. The maximum percentage gain in Regenerative feed heating cycle thermal efficiency

- (a) increases with number of feed heaters increasing
- (b) decreases with number of feed heaters increasing
- (c) remains same unaffected by number of feed heaters
- (d) none of the above

Ans: a

23. In regenerative cycle feed water is heated by

- (a) exhaust gases
- (b) heaters
- (c) draining steam from the turbine
- (d) all above

Ans: c

24. Reheat cycle in steam power plant is used to

- (a) utilise heat of flue gases
- (b) increase thermal efficiency
- (c) improve condenser performance
- (d) reduce loss of heat

Ans: b

25. Mercury is a choice with steam in binary vapour cycle because it has

- (a) higher critical temperature and pressure
- (b) higher saturation temperature than other fluids
- (c) relatively low vapourisation pressure
- (d) all above

Ans: d

26. Binary vapour cycles are used to

- (a) increase the performance of the condenser
- (b) increase the efficiency of the plant
- (c) increase efficiency of the turbine

Ans: b

27. A steam power station requires space

- (a) equal to diesel power station
- (b) more than diesel power station
- (c) less than diesel power station

Ans: b

28. Economiser is used to heat

- (a) air
- (b) feed water
- (c) flue gases
- (d) all above

Ans: b

29. The modern steam turbines are

- (a) impulse turbines
- (b) reaction turbines
- (c) impulse-reaction turbines
- (d) none of the above

Ans: c

30. The draught which a chimney produces is called

- (a) induced draught
- (b) natural draught
- (c) forced draught
- (d) balanced draught

Ans: b

29. The modern steam turbines are

- (a) impulse turbines
- (b) reaction turbines
- (c) impulse-reaction turbines
- (d) none of the above

Ans: c

30. The draught which a chimney produces is called

- (a) induced draught
- (b) natural draught
- (c) forced draught
- (d) balanced draught

Ans: b

31. The draught produced by steel chimney as compared to that produced by brick chimney for the same height is

- (a) less
- (b) more
- (c) same
- (d) may be more or less

Ans: b

32. In a boiler installation the natural draught is produced

- (a) due to the fact that furnace gases being light go through the chimney giving place to cold air from outside to rush in
- (b) due to the fact that pressure at the grate due to cold column is higher than the pressure at

the chimney base due to hot column

- (c) due to the fact that at the chimney top the pressure is more than its environmental pressure
- (d) all of the above

Ans: b

33. The draught produced, for a given height of the chimney and given mean temperature of chimney gases

- (a) decreases with increase in outside air temperature
- (b) increases with increase in outside air temperature
- (c) remains the same irrespective of outside air temperature
- (d) may increase or decrease with increase in outside air temperature

Ans: a

34. The draught produced by chimney of given height at given outside temperature

- (a) decreases if the chimney gas temperature increases
- (b) increases if the chimney gas temperature increases
- (c) remains same irrespective of chimney gas temperature
- (d) may increase or decrease

Ans: b

35. For forced draught system, the function of chimney is mainly

- (a) to produce draught to accelerate the combustion of fuel
- (b) to discharge gases high up in the atmosphere to avoid hazard
- (c) to reduce the temperature of the hot gases discharged
- (d) none of the above

Ans: b

36. Artificial draught is produced by

- (a) induced fan
- (b) forced fan
- (c) induced and forced fan
- (d) all of the above

Ans: d

37. The draught in locomotive boilers is produced by

- (a) forced fan
- (b) chimney
- (c) steam jet
- (d) only motion of locomotive

Ans: c

38. For the same draught produced the power of induced draught fan as compared to forced draught fan is

- (a) less
- (b) more
- (c) same
- (d) not predictable

Ans: b

39. Artificial draught is produced by

- (a) air fans
- (b) steam jet
- (c) fan or steam jet
- (d) all of the above

Ans: d

40. The artificial draught normally is designed to produce

- (a) less smoke
- (b) more draught
- (c) less chimney gas temperature
- (d) all of the above

Ans: d

41. For the induced draught the fan is located

- (a) near bottom of chimney
- (b) near bottom of furnace
- (c) at the top of the chimney
- (D) anywhere permissible

Ans: a

42. The pressure at the furnace is minimum in case of

- (a) forced draught system
- (b) induced draught system
- (c) balanced draught system
- (d) natural draught system

Ans: c

43. The efficiency of chimney is approximately

- (a) 80%
- (b) 40%

- (c) 20%
- (d) 0.25%

Ans: d

44. The isentropic expansion of steam through nozzle for the steam initially superheated at inlet is approximated by equation

- (a) $pv^{1.5} = C$
- (b) $pv^{1.26} = C$
- (c) $pv^{1.4} = C$
- (d) $pv = C$

Ans: a

45. The ratio of exit pressure to inlet pressure for maximum mass flow rate per unit area of steam through a nozzle when steam is initially dry saturated is

- (a) 0.6
- (b) 0.578
- (c) 0.555
- (d) 0.5457

Ans: b

46. The ratio of exit pressure to inlet pressure of maximum mass flow rate per area of steam through a nozzle when steam is initially superheated is

- (a) 0.555
- (b) 0.578
- (c) 0.5457
- (d) 0.6

Ans: c

47. The critical pressure ratio of a convergent nozzle is defined as

- (a) the ratio of outlet pressure to inlet pressure of nozzle
- (b) the ratio of inlet pressure to outlet pressure of nozzle
- (c) the ratio of outlet pressure to inlet pressure only when mass flow rate per unit area is minimum
- (d) the ratio of outlet pressure to inlet pressure only when mass flow rate = c

Ans: d

48. The isentropic expansion of steam through nozzle for the steam initially dry saturated at inlet is approximated by equation.

- (a) $pv = C$
- (b) $pv^{1.4} = C$

- (c) $p v^{1i} = C$
 (d) $p v$

Ans: d

49. The effect of considering friction losses in steam nozzle for the same pressure ratio leads to

- (a) increase in exit velocity from the nozzle
 (b) decrease in exit velocity from the nozzle
 (c) no change in exit velocity from the nozzle
 (d) increase or decrease depending upon the exit quality of steam

Ans: b

50. The effect of considering friction in steam nozzles for the same pressure ratio leads to

- (a) increase in dryness fraction of exit steam
 (b) decrease in dryness fraction of exit steam
 (c) no change in the quality of exit steam
 (d) decrease or increase of dryness fraction of exit steam depending upon inlet quality

Ans: a

51. In case of impulse steam turbine

- (a) there is enthalpy drop in fixed and moving blades
 (b) there is enthalpy drop only in moving blades
 (c) there is enthalpy drop in nozzles
 (d) none of the above

Ans: c

52. The pressure on the two sides of the impulse wheel of a steam turbine

- (a) is same
 (b) is different
 (c) increases from one side to the other side
 (d) decreases from one side to the other side

Ans: a

53. In De Laval steam turbine

- (a) the pressure in the turbine rotor is approximately same as in condenser
 (b) the pressure in the turbine rotor is higher than pressure in the condenser
 (c) the pressure in the turbine rotor gradually decreases from inlet to exit from condenser
 (d) none from the above

Ans: a

54. Incase of reaction steam turbine

- (a) there is enthalpy drop both in fixed and moving blades
- (b) there is enthalpy drop only in fixed blades
- (c) there is enthalpy drop only in moving blades
- (d) none of the above

Ans: a

55. Curtis turbine is

- (a) reaction steam turbine
- (b) pressure velocity compounded steam turbine
- (c) pressure compounded impulse steam turbine
- (d) velocity compounded impulse steam turbine

Ans: b

56. Rateau steam turbine is

- (a) reaction steam turbine
- (b) velocity compounded impulse steam turbine
- (c) pressure compounded impulse steam turbine
- (d) pressure velocity compounded steam turbine

Ans: c

57. Parson's turbine is

- (a) pressure compounded steam turbine
- (b) simple single wheel, impulse steam turbine
- (c) simple single wheel reaction steam turbine
- (d) multi wheel reaction steam turbine

Ans: d

58. For Parson's reaction steam turbine, degree of reaction is

- (a) 75%
- (b) 100%
- (c) 50%
- (d) 60%

Ans: c

59. Reheat factor in steam turbines depends on

- (a) exit pressure only
- (b) stage efficiency only

- (c) initial pressures and temperature only
- (d) all of the above

Ans: c

60. The value of reheat factor normally varies from

- (a) 0.5 to 0.6
- (b) 0.9 to 0.95
- (c) 1.02 to 1.06
- (d) 1.2 to 1.6

Ans: c

61. Steam turbines are governed by the following methods

- (a) Throttle governing
- (b) Nozzle control governing
- (c) By-pass governing
- (d) all of the above

Ans: d

62. In steam turbines the reheat factor

- (a) increases with the increase in number of stages
- (b) decreases with the increase in number of stages
- (c) remains same irrespective of number of stages
- (d) none of the above

Ans: a

63. The thermal efficiency of the engine with condenser as compared to without condenser, for a given pressure and temperature of steam, is

- (a) higher
- (b) lower
- (c) same as long as initial pressure and temperature is unchanged
- (d) none of the above

Ans: a

64. In jet type condensers

- (a) cooling water passes through tubes and steam surrounds them
- (b) steam passes through tubes and cooling water surrounds them
- (c) steam and cooling water mix
- (d) steam and cooling water do not mix

Ans: c

65. In a shell and tube surface condenser

- (a) steam and cooling water mix to give the condensate
- (b) cooling water passes through the tubes and steam surrounds them
- (c) steam passes through the cooling tubes and cooling water surrounds them
- (d) all of the above varying with situation

Ans: b

66. In a surface condenser if air is removed, there is

- (a) fall in absolute pressure maintained in condenser
- (b) rise in absolute pressure maintained in condenser
- (c) no change in absolute pressure in the condenser
- (d) rise in temperature of condensed steam

Ans: a

67. The cooling section in the surface condenser

- (a) increases the quantity of vapour extracted along with air
- (b) reduces the quantity of vapour extracted along with air
- (c) does not affect vapour quantity extracted but reduces pump capacity of air extraction pump
- (d) none of the above

Ans: b

68. Edward's air pump

- (a) removes air and also vapour from condenser
- (b) removes only air from condenser
- (c) removes only un-condensed vapour from condenser
- (d) removes air alongwith vapour and also the condensed water from condenser

Ans: d

69. In a steam power plant, the function of a condenser is

- (a) to maintain pressure below atmospheric to increase work output from the primemover
- (b) to receive large volumes of steam exhausted from steam prime mover
- (c) to condense large volumes of steam to water which may be used again in boiler
- (d) all of the above

Ans: d

70. In a regenerative surface condenser

- (a) there is one pump to remove air and condensate
- (b) there are two pumps to remove air and condensate

- (c) there are three pumps to remove air, vapour and condensate
- (d) there is no pump, the condensate gets removed by gravity

Ans: b

71. Evaporative type of condenser has

- (a) steam in pipes surrounded by water
- (b) water in pipes surrounded by steam
- (c) either (a) or (b)
- (d) none of the above

Ans: a

72. Pipes carrying steam are generally made up of

- (a) steel
- (b) cast iron
- (c) copper
- (d) aluminium

Ans: a

73. For the safety of a steam boiler the number of safety valves fitted are

- (a) four
- (b) three
- (c) two
- (d) one

Ans: c

74. Steam turbines commonly used in steam power station are

- (a) condensing type
- (b) non-condensing type
- (c) none of the above

Ans: a

75. Belt conveyer can be used to transport coal at inclinations upto

- (a) 30°
- (b) 60°
- (c) 80°
- (d) 90°

Ans: a

76. The maximum length of a screw conveyer is about

- (a) 30 metres
- (b) 40 metres
- (c) 60 metres
- (d) 100 metres

Ans: a

77. The efficiency of a modern boiler using coal and heat recovery equipment is about

- (a) 25 to 30%
- (b) 40 to 50%
- (c) 65 to 70%
- (d) 85 to 90%

Ans: d

78. The average ash content in Indian co als is about

- (a) 5%
- (b) 10%
- (c) 15%
- (d) 20%

Ans: d

79. Load centre in a power station is

- (a) centre of coal fields
- (b) centre of maximum load of equip-ments
- (c) centre of gravity of electrical system

Ans: c

80. Steam pressure in a steam power station, which is usually kept now-a-days is of the order of

- (a) 20 kgf/cm²
- (b) 50 kgf/cm²
- (c) 100 kgf/cm²
- (d) 150 kgf/cm²

Ans: d

81. Economisers improve boiler efficiency by

- (a) 1 to 5%
- (b) 4 to 10%
- (c) 10 to 12%

Ans: b

82. The capacity of large turbo-generators varies from

- (a) 20 to 100 MW
- (b) 50 to 300 MW
- (c) 70 to 400 MW
- (d) 100 to 650 MW

Ans: b

83. Caking coals are those which

- (a) burn completely
- (b) burn freely
- (c) do not form ash
- (d) form lumps or masses of coke

Ans: d

84. Primary air is that air which is used to

- (a) reduce the flame length
- (b) increase the flame length
- (c) transport and dry the coal
- (d) provide air around burners for getting optimum combustion

Ans: c

85. Secondary air is the air used to

- (a) reduce the flame length
- (b) increase the flame length
- (c) transport and dry the coal
- (d) provide air round the burners for getting optimum combustion

Ans: d

86. In coal preparation plant, magnetic separators are used to remove

- (a) dust
- (b) clinkers
- (c) iron particles
- (d) sand

Ans: c

87. Load carrying capacity of belt conveyor is about

- (a) 20 to 40 tonnes/hr
- (b) 50 to 100 tonnes/hr
- (c) 100 to 150 tonnes/hr
- (d) 150 to 200 tonnes/hr

Ans: b

88. Method which is commonly applied for unloading the coal for small power plant is

- (a) lift trucks
- (b) coal accelerators
- (c) tower cranes
- (d) belt conveyor

Ans: b

89. Bucket elevators are used for

- (a) carrying coal in horizontal direction
- (b) carrying coal in vertical direction
- (c) carrying coal in any direction

Ans: b

90. The amount of air which is supplied for complete combustion is called

- (a) primary air
- (b) secondary air
- (c) tertiary air

Ans: b

91. In _____ system fuel from a central pulverizing unit is delivered to a bunker and then to the various burners

- (a) unit
- (b) central
- (c) none of the above

Ans: b

92. Under-feed stokers work best for _____ coals high in volatile matter and with caking tendency

- (a) anthracite
- (b) lignite
- (c) semibituminous and bituminous

Ans: c

93. Example of overfeed type stoker is

- (a) chain grate
- (b) spreader
- (c) travelling grate
- (d) all of the above

Ans: d

94. Where unpulverised coal has to be used and boiler capacity is large, the stoker which is used is

- (a) underfeed stoker
- (b) overfeed stoker
- (c) any

Ans: b

95. Traveling grate stoker can burn coals at the rates of

- (a) 50—75 kg/m per hour
- (b) 75—100 kg/m per hour
- (c) 100—150 kg/m per hour
- (d) 150—200 kg/m² per hour

Ans: d

96. Blowing down of boiler water is the process

- (a) to reduce the boiler pressure
- (b) to increase the steam temperature
- (c) to control the solid concentration in the boiler water by removing some of the concentrated saline water
- (d) none of the above

Ans: c

97. Deaerative heating is done to

- (a) heat the water
- (b) heat the air in the water
- (c) remove dissolved gases in the water

Ans: c

98. Reheat factor is the ratio of

- (a) isentropic heat drop to useful heat drop
- (b) adiabatic heat drop to isentropic heat drop
- (c) cumulative actual enthalpy drop for the stages to total isentropic enthalpy heat drop

Ans: c

99. The value of the reheat factor is of the order of

- (a) 0.8 to 1.0
- (b) 1.0 to 1.05
- (c) 1.1 to 1.5
- (d) above 1.5

Ans: c

100. Compounding of steam turbine is done for

- (a) reducing the work done
- (b) increasing the rotor speed
- (c) reducing the rotor speed
- (d) balancing the turbine

Ans: c

Assignment / QUESTION BANK**UNIT - I****(PART-A)**

1. What are the thermal power plant (Steam) circuits?
2. What are the two major advantages of thermal power plant?
3. What do you understand by water hammer?
4. State any two major advantages of hydro power plant.
5. What are the components of nuclear power plant?
6. Explain the term nuclear fission.
7. What is the function of moderator and give examples?
8. State any two application of the diesel power plant?
9. State any two application of gas turbine power plant?
10. What is the use of regenerator?
11. Write principle of Solar cell?
12. Write importance of instrumentation in power plant.
13. Write some nuclear fuels.
14. What is a function of surge tank?
15. What is a function of super heater?
16. What is a function of Reheater?
17. What is a function of Penstock?
18. What is an isotope? Give example.
19. What is a function of Economizer?
20. What is a function of Control rods?
21. What is cogeneration?
22. What is fission? Give some fission materials.

23. What are the types of solar energy collectors?
24. How wind energy is converted into electrical energy?
25. What are advantages and disadvantages of hydro plant?

UNIT - II

(PART – A)

1. Write the principle of ionization chamber or ionization smoke detectors.
2. Write the principle of fire alert ionizing chamber.
3. What is the principle of steam purity meter?
4. What are primary measurements of power plant?
5. What is the principle of smoke density measurement?
6. What is the principle of radiation detector?
7. What do you mean by swelling effect of boiler drum level?
8. What are the types of radiation detectors?
9. What are the instruments used to measure feed water temperature?
10. What are the different methods of power factor measurement?
11. What are secondary power plant measurements?
12. What are parameters involved in measuring electrical measurements in power plants?
13. How the air flow is measured?
14. How voltage is measured in power plants?
15. Why drum level measurement is critical?
16. What is the use of dust monitor?
17. What is the difficulty in sight glass technique in boiler level measurement?
18. How to measure frequency of the electrical signal?
19. What do you mean by shrinking effect of boiler drum level?
20. What is the principle of Electro dynamometer?

UNIT - III

(PART –A)

1. Why flue gas has to be measured?

2. What is the principle of Thermal Conductivity analyzer?
3. What is the principle of steam purity meter?
4. What is the principle of paramagnetic analyzer
5. What is the principle of chromatography
6. What is the effect of variation of feed water PH?
7. What is the effect of high electrical conductivity in boiler water?
8. What is fuel analyzer?
9. What is flue gas analyzer?
10. What are the different types of measuring PH?
11. What are the different types of chromatography?
12. What is the different section of gas chromatography?
13. What are the different methods of gas analysis?
14. What are the advantages and disadvantages of dissolved oxygen analyzer?
15. What are the limitations of liquid chromatography?
16. What are the limitations of gas chromatography?
17. Define pH meter.
18. Why we need pollution monitoring instruments?
19. How the hydrocarbons enter into the atmosphere?
20. What is the use of CO₂ recorder?
21. Why do we need to analyze oxygen content in flue gas?
22. What do you mean by deaerated water?
23. What is the indication of incomplete combustion in boiler?
24. How the carbon monoxide emitted into the atmosphere?
25. Name any two instruments to find CO in flue gas?

UNIT- IV**(PART-A)**

1. What is the difference between forced draft and induced draft fans?
2. What is reheating control?
3. What is ratio control?
4. What is the necessity of superheated steam flow measurements?
5. What is furnace implosion?
6. What is furnace draft control?
7. What is desuperheater?
8. What is deaeration?
9. What are the types of feed water control?
10. What are the types of super heater?
11. What are the requirements to be considered for firing due to load change?
12. What are the methods used for steam temperature control?
13. What are the functions of super heater and reheater?
14. What are the drawbacks of single element feed water control?
15. What are the draft losses in boiler?
16. What is boiler blow down?
17. What are the methods of measurement of combustion air flow?
18. What is draft (draught)?
19. What is natural draft?
20. What is artificial draft?

UNIT – V**(PART – A)**

1. Enlist the various components of cooling system
2. How steam temperature affects efficiency of boiler?
3. How to measure speed of turbine?
4. Why do we need to measure vibration of turbine blades?
5. Name the sensors used in measuring vibration?

6. How to steam pressure is inter linked with turbine governors?
7. What do you mean by high pressure and low pressure turbine?
8. What is the use of auxiliary steam?
9. What are turbine losses?
10. List the methods to control the steam pressure.
11. Why do we need to control lubricant oil?
12. Define turbine efficiency.
13. What are the types of gas turbine?
14. List the methods to measure speed of turbine.
15. How to control the shell temperature?
16. How to control the speed of turbine?
17. How to control the vibration of turbine blades?
18. What are the advantages and disadvantages of wet cooling?
19. What are the advantages and disadvantages of dry cooling?
20. What are the different methods of dry cooling?

UNIT – I
(PART – B)

1. Compare the various methods of power generation and present the summary in a table from various factors.
2. Draw the overall layout of thermal power plant and present the four major cycles of operation involved.
3. Explain the boiler process with neat diagram.
4. With a neat sketch explain the process of electric power generation in a nuclear power plant.
5. With neat sketch, explain in detail the constructional feature and operation of thermal power plant.

6. With a block diagram, explain operation of thermal power plant and mention the important parameters to be monitored in each block.

7. Draw and mention the function of piping and instrumentation diagram of a boiler system in a power plant.

8. With neat sketches explain the process of converting solar energy into electrical energy.

9. What is meant by cogeneration? Also explain the topping and bottoming cycle operation of cogeneration system.

10. Briefly explain the importance of instrumentation in power generation.

11. Describe the different types of steam generations.

12. Briefly explain about the principle of solar power plant with neat diagram.

13. Discuss with a neat sketch the process of electric power generation using solar and wind energy system.

14. With a neat schematic diagram describe the processes happening in a boiler.

15. With a neat schematic diagram explain in detail the steam generation in a drum boiler and various processes in a drum boiler in a power generating plant.

16. Discuss a method of harnessing the wind with neat diagram.

17. Mention the four significant need of instrumentation in power generation and explain any one power generation

18. Describe the different types of systems and components which are used in thermal power plants.

19. Explain about the SAMA control diagramming system with neat diagram.

20. Explain about the basic components and classification of wind energy Conversion system with neat block diagram.

UNIT – II
(PART – B)

1. Explain any two electrical parameters do you think is a must to be measured in power plants.

2. Explain how a radiation detector is useful for measurement in power plant.

3. Explain how moisture is eliminated from saturated steam with relevant sketches of the equipment in a steam power plant.

4. Explain how a U – tube mercury manometer can be used for measuring steam pressure. Which device is suitable for high pressure? Explain the operation of the same.

5. Explain a primary and secondary element each in the measurement of feed water flow.

6. Explain the principle of vortex flow meter with neat sketch.

7. Specify the need of drum level measurement. Also explain the differential pressure method to measure the drum level in high pressure boiler.

8. Explain how real power and reactive power can be measured.
9. Explain the different methods of measuring power frequency with relevant sketches.
10. What is boiler drum? Explain in detail measurement of drum level.
11. Classify the transducers based on low, medium and high temperature applications. Also list the major temperature measurement points and suggest suitable sensors.
12. List the various types of radiation detector. Also explain the method of measuring dissolved oxygen content.
13. Explain the types of strain gauge pressure transducer.
14. Which device is used for high pressure measurement in power plants? Explain the operation of the high pressure measurement in power plants.
15. Explain with neat sketches capsules and bellows gauges.
16. Describe the construction and operation of smoke density measurement.
17. What is the objective of a feed water control system? Explain three element feed water control method with necessary sketch.
18. Explain the construction and operation of Dust monitoring system.

19. With suitable diagram, explain the principle of Electromagnetic type flow meters. Also mention its advantages and limitations.

20. Name the type of differential pressure flow meter used in a feed water line of a boiler. Explain its principle of operation with a neat diagram. What are the advantages of venturimeter over orifice and flow nozzle?

UNIT - III

(PART – B)

1. Name the important instruments used in pollution monitoring. Explain any one type in detail.
2. Give a descriptive note on chromatography and its role in power plants.
3. Describe the short notes on fuel analyzer and its significance.
4. Explain about the analysis of impurities in feed water and water treatment with neat sketch.
5. Explain the flue gas oxygen analysis performed and its methods adopted.
6. Explain the dust monitor with neat sketch.
7. List the various parameters to be monitor in feed water. Also explain the method of measuring an electrochemical dissolved oxygen meter.
8. Describe in detail about the flue gas oxygen analyzer.
9. Explain the working principle of katharometer dissolved oxygen meter.

10. What are the impurities in feed water and steam? How can their presence be detected? Explain the schemes in short.

11. Define pH meter. What should be the pH of the pure water? Describe a method to measure pH.

12. With a neat sketch explain the different methods of feed water treatment.

UNIT – IV

(PART – B)

1. Explain the furnace draft control systems with neat sketch.

2. Describe the features adopted in main steam , reheat steam and super heater temperature control.

3. Explain interlocks in boiler with neat diagram.

4. With a SAMA diagram, explain a simple feedback control in a process. Assume a proportional plus integral control function.

5. With a block diagram, describe the function of a distributed control system of a power plant.

6. Explain with SAMA or ISA diagrams three element drum level control steam temperature in boiler.

7. Discuss about the air / fuel ratio control.
8. With a neat diagram explain the principle of a deaerator.
9. Describe how air is delivered to the furnace at the right conditions of flow and temperature, with air heater and different types of fans in the draught plant.
10. With a neat sketch explain the principles and operation of “cross limited” combustion control system.
11. With suitable sketches explain boiler following firing rate control and turbine following firing rate control.
12. Explain the term oxygen limit control in boiler operation? How is it performed?
13. Difference between induced and forced draft fan. How are they measured and controlled? Describe in detail with neat sketch.

UNIT - V

(PART – B)

1. Discuss in briefly on the turbine – boiler monitoring and control schemes.
2. Explain briefly about the types of cooling system with neat diagram.
3. Explain briefly about the shell temperature monitoring and control.
4. Explain with suitable diagrams two non contact type speed measurement methods.

5. List the various parameters need for turbine supervisory control system. Also explain the technique for the measurements of the parameters.

6. Why is vibration measurement essential in turbine control? Also explain the method vibration measurement in steam turbine.

7. Explain the lubricant oil temperature control scheme in briefly.

8. Explain various methods of measuring steam pressure.

9. Describe the steam temperature and pressure monitoring in power plants.

10. Discuss the various parameters to be monitored for smooth running of turbine? Also explain the operation of differential expansion detector.

USEFUL VIDEO LINK

UNIT –I

OVERVIEW OF POWER GENERATION

Brief survey of methods of power generation

<https://www.youtube.com/watch?v=jIddkVnc7pY>

Hydro

<https://www.youtube.com/watch?v=Ujhufhg3Xk>

Thermal

<https://www.youtube.com/watch?v=IdPTuwKEfmA>

Nuclear

<https://www.youtube.com/watch?v=ke1L4An1yP8>

Solar

<https://www.youtube.com/watch?v=xKxrkht7CpY>

Wind

https://www.youtube.com/watch?v=qSWm_nprfqE

Importance of instrumentation in power generation

<https://www.youtube.com/watch?v=C7PMOUEgEo4>

Thermal power plants – building blocks

<https://www.youtube.com/watch?v=3EUzVOIQ1Ag>

Details of boiler processes UP&I diagram of boiler

<https://www.youtube.com/watch?v=nxvav0Ijd4E>

<https://www.youtube.com/watch?v=mmSennUmkvQ>

Cogeneration

<https://www.youtube.com/watch?v=2mw2h7FMPh8>

UNIT – II
MEASUREMENTS IN POWER PLANTS

Electrical measurements

https://www.youtube.com/watch?v=xLjk5DrScEU&list=PLt5syl71JKf0IacRzLI-02Q_udP4nJiJg

Non electrical parameters

<https://www.youtube.com/watch?v=8g2VLcWdsBs>

Flow of feed water

<https://www.youtube.com/watch?v=is5wdVgPOkI>

Steam Fuel ratio Calculation

<https://www.youtube.com/watch?v=9fpVI7U1G08&pbjreload=101>

Steam pressure and steam temperature

https://www.youtube.com/watch?v=ATULQO_5rt8

Drum level measurement

<https://www.youtube.com/watch?v=yRK4eJIt2YY>

Radiation detector

<https://www.youtube.com/watch?v=iMCPceBP1ks>

Smoke density measurement

https://www.youtube.com/watch?v=oqhXVBaJ_rY

Dust monitor

<https://www.youtube.com/watch?v=X3N-GsNe9Sw>

UNIT –III

ANALYZERS IN POWER PLANTS

Flue gas oxygen analyzer

<https://www.youtube.com/watch?v=ZoiSKJGxFjc>

Analysis of impurities in feed water and steam

<https://www.youtube.com/watch?v=ugDRuS8dtY4>

Dissolved oxygen analyzer

<https://www.youtube.com/watch?v=y7zbmlEaPAs>

Chromatography

https://www.youtube.com/watch?v=XMtmSz_9umk

PH meter

<https://www.youtube.com/watch?v=oEHRg2IoxKo>

Pollution monitoring instruments

<https://www.youtube.com/watch?v=GHS5Sw-pwGNw>

UNIT –IV

CONTROL LOOPS IN BOILER

Combustion control

<https://www.youtube.com/watch?v=vBGpyxbnp50>

Air/fuel ratio control

https://www.youtube.com/watch?v=9kyw1xfn__c

Furnace draft control

<https://www.youtube.com/watch?v=hqvyBvJLtmw>

Drum level control

<https://www.youtube.com/watch?v=I3C59TR9OBQ>

Main stem and reheat steam temperature control – super heater control

https://www.youtube.com/watch?v=qRT_TXgpIso

Deaerator control

<https://www.youtube.com/watch?v=3wJ8m-skuPQ>

Distributed control system in power plants

<https://www.youtube.com/watch?v=jXRksET5vNo>

Interlocks in boiler operation

<https://www.youtube.com/watch?v=Aps8IzU1m4g>

Nuclear power plant instrumentation

<https://www.youtube.com/watch?v=pM0VPxJFtck>

Radiations detection instruments

<https://www.youtube.com/watch?v=j4uqdOwTa-A>

Process sensors

<https://www.youtube.com/watch?v=AR7W8L5Ggxo>

Spectrum Analyzer

<https://www.youtube.com/watch?v=YjLZQlejBGQ>

Nuclear reactor control systems

<https://www.youtube.com/watch?v=1U6Nzcv9Vws>

UNIT- V

TURBINE – MONITORING AND CONTROL

Speed

<https://www.youtube.com/watch?v=SPg7hOxFtI>

steam pressure control

<https://www.youtube.com/watch?v=6-52FIgiQHs>

lubricant oil temperature control

<https://www.youtube.com/watch?v=I-YBRzVdPbA>

Cooling system

<https://www.youtube.com/watch?v=vFawmDQrhWI>

CONCLUSION

The basic concepts of power generation system are discussed in detail with different methods available in the generating plant. Different technological methods were studied to measure various measurements involved in the power generation system. A detail discussion on different types of devices used to analyze the power generation system is done. A deep knowledge in types of controllers and control loop are analyzed. The students were familiar with function of power generation plant with the instrumentation availability in the modern generation.

REFERENCES

1. Sam G. Dukelow, The control of Boilers, instrument Society of America, 1991.
2. Modern Power Station Practice, Vol.6, Instrumentation, Controls and Testing, Pergamon Press, Oxford, 1971.
3. Liptak B.G., Instrumentation in Process Industries, Chilton, 1973
4. P.Tamilmani, power plant instrumentation, sams publishers, Chennai.
5. P.K.Nag, Powerplant Engineering, Tata McGraw-Hill Education, 3rd edition, 2007.
6. Krishnaswamy.K and Ponnibala.M., Power Plant Instrumentation, PHI Learning Pvt.Ltd., New Delhi, 2011.
7. Elonka,S.M.and Kohal A.L.Standard Boiler Operations, McGraw Hill, New Delhi, 1994.

- 8.R.K.Jain, Mechanical and industrial Measurements, Khanna Publishers, New Delhi, 1995.
9. Everett Woodruff , Herbert Lammers, Thomas Lammers, Steam Plant Operation,9th Edition
McGraw Hill, 2012.
10. Rajput R.K., A Text book of Power plant Engineering. 5th Edition, Lakshmi Publications, 2013.
11. E.Al. Wakil, 'Power Plant Engineering', Tata McGraw Hill, 1984.

Never say 'No', never say
'I cannot', for you are infinite.
All the power is within you.
You can do anything.

— *Swami Vivekananda*

